



## **INSTALLATION DATA MANUAL**

### **MODEL 423**

### **PRESSURE TRANSMITTER**

**DSPM Industria\***  
sensori & trasduttori

Via Paolo Uccello 4 - 20148 Milano  
Tel +39 02 48 009 757 Fax +39 02 48 002 070  
info@dspmindustria.it www.dspmindustria.it

## PRODUCT OVERVIEW

All information contained in this document is representative of a **standard** Model 423. If the product you ordered has special requirements or modifications, refer to the Laser Marked information on the product and your purchase order for possible alteration to the product's configuration. Failure to verify product configuration before installation may cause permanent product damage and in most cases, void the manufacturer's product warranty. If you are unsure or have questions about your product, please contact our Application Engineers for assistance.

Remove and retain all instruction manuals and performance certificates that are shipped with the product. These documents provide important information on the product's calibration, operation, safety precautions, recommended maintenance, re-calibration requirements, repair service instructions and warranty information. These documents are updated from time to time as changes to the product occur and should be reviewed at receipt so that proper and safe installation can occur.

## INSTALLATION REQUIREMENTS & CAUTIONS

1. All electrical & pressure connections should be compatible with the model specifications as outlined above.
2. Installation should occur only after electrical (input power) and line pressure is verified as being off and at zero.
3. The case or ground of the unit should not be connected to the input, output or calibrate pins of the product or wiring system. Ground loops and line noise will affect the product's performance and will in most cases cause internal electrical failure. In no case should power be applied to the transducer housing.
4. All products should be protected from direct or continued exposure to fluids at the electrical connection. It is recommended that for products installed in areas where the potential for contamination at the electrical connection is possible a "boot" or other protective measure be taken to eliminate possible deterioration of the product's electrical connection and corrosion that will impede product performance.
5. On some lower range models a breather opening, with breather plug, is used to allow for proper product function. At no time should any mist, vapor or fluid be permitted to enter this breather as total unit failure could occur.
6. At no time should an object be inserted into the pressure port or pressed against the sensing area to deflect the sensor (to test or simulate pressure), as permanent damage to the sensing diaphragm may occur.
7. Internal damage may occur if the transmitter receives a serious shock due to being dropped or struck by a foreign object.
8. When shipped in quantities, units should be packaged individually to eliminate possible damage.
9. The Model 423 is CE compliant. The CE circuitry requires the transducer housing to be grounded. Power should not be applied to the housing.

## BASIC OPERATION

The Model 423 has been pre-set at the factory for the required output. The standard output is 4-20 mA. With the exception of absolute units which are referenced to absolute zero (full vacuum), all other products are referenced to atmospheric pressure (zero PSIG). Once factory set, the product should perform as indicated by the performance certificate and product labeling.

- A. For compound ranges, (a negative pressure to a positive pressure, i.e. -15 to +15), the zero balance will occur and be set for zero PSIG. For the compound range the output of the transmitter will be evenly and proportionately split between the plus and minus pressure ranges with respect to zero. The output would be plus or minus depending on the type of pressure applied to the pressure port.
- B. Output for gage and sealed units will go positive with positive pressure applied to the pressure port.
- C. With vacuum units, the output will go positive with increased vacuum at its pressure port.
- D. For absolutes, the pressure port must have a full vacuum applied to reach the absolute zero point. After the full vacuum is applied, the unit will begin to read positive pressure changes as less and less of a vacuum is evident at the pressure port.

## INSTALLATION DATA - VIATRAN MODEL 423

*Note: The drawing below is for informational purposes only and is not to scale. All dimensions are nominal, in inches and for reference purposes only.*

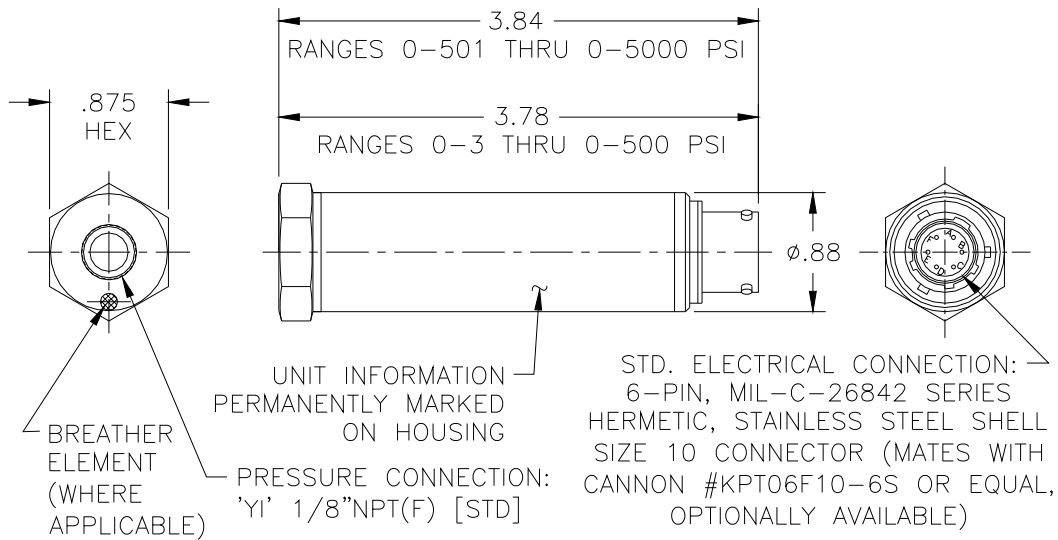

**Excitation Voltage:** 8-28 VDC

**Output:** 4-20 mA

**Pressure Connection:** 1/8" NPT(F) standard

**Electrical Connector:** 6 Pin bayonet SST standard

**Sensor Construction and Wetted Materials:** Oil Filled – Silicon, 316L Stainless Steel

### WIRING & CONNECTION DIAGRAMS

- Pin A: +Excitation
- Pin B: -Excitation
- Pin C: No Connection
- Pin D: No Connection
- Pin E: AC Ground (standard)
- Pin F: No Connection

**NOTE:**

Connecting Power to Pin F or the transducer housing may damage unit

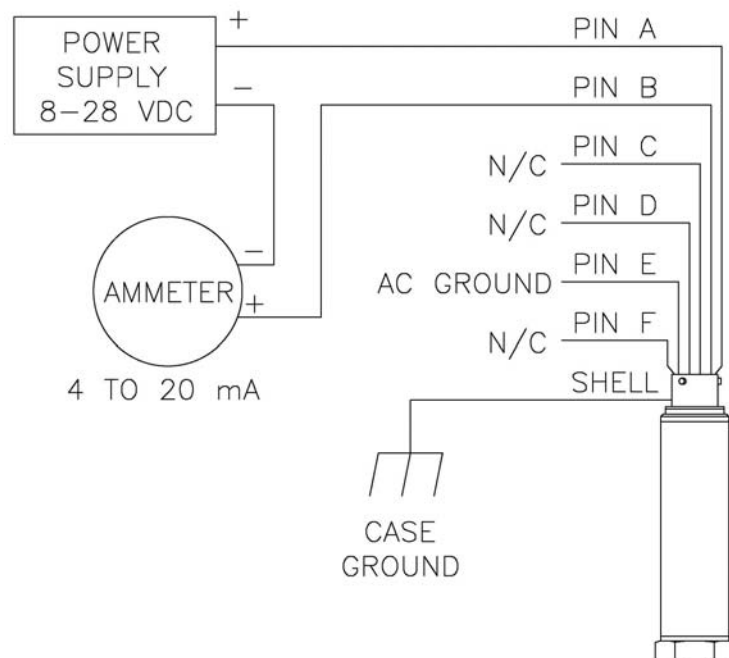

## **MAINTENANCE AND REPAIR**

All Viatran transmitters have been designed to function free from routine or scheduled maintenance. Simple cleaning of the electrical connector, pressure port threads and pressure cavity on an as needed basis will provide many years of satisfactory performance. Protecting the product from continued exposure to moisture or fluids at the electrical connection, breather area (range dependent) will eliminate premature internal failure of the product. Generally any time the product is removed from service the connector and pressure port threads should be cleaned and the pressure cavity flushed with a stainless steel and/or O-Ring (material/model dependent) compatible cleaner to prevent media buildup. During the cleaning process only a soft, lint-free cloth is recommended. Never use a coarse or stiff bristle brush to clean media from the diaphragm surface.

It is suggested that the calibration be verified on a usage dependent schedule. If the product is in continuous service 7 days a week, then calibration verification may be necessary every 6 to 8 months. If the product is in a lab test environment a more lenient verification schedule would be appropriate. In all instances the performance of the product will depend on the individual application or process in which it is installed. More continued usage would require a shorter period between calibration verification and product maintenance.

If a product is perceived to be exhibiting problems, it can be returned to Viatran for analysis and/or repair. It is suggested that only Viatran personnel attempt repair of the product. Any damage resulting from customer disassembly would result in a loss of coverage under the warranty policy. All Viatran products are able to be repaired at minimal cost if simple cleaning and precautions are taken in the handling and application of the product. Older products returned for repair are updated to current specifications unless the repair cost would outweigh the cost of a new replacement model. Products returned for repair should include information on the person to contact for repair quote approval, the individual to contact if Viatran's technical staff requires additional information during analysis, and a brief description of the problem associated with the product's failure.

## **WARRANTY**

Viatran Corporation warrants that its products shall be free from defective workmanship and/or material for a period of twelve (12) months from the date of shipment, provided that Viatran's obligation hereunder shall be limited to correcting any defective workmanship and/or replacing any defective material f.o.b. factory. No allowance will be made for any expense incurred for correcting any defective workmanship and/or material without written consent by Viatran. This warranty is in lieu of all other warranties expressed or implied.

## **REPAIR INSTRUCTIONS**

Viatran's Transmitters are designed to be easily repaired and recalibrated if necessary. If a failure occurs, the transmitter should be returned to the factory for inspection and testing.



Via Paolo Uccello 4 - 20148 Milano  
Tel +39 02 48 009 757 Fax +39 02 48 002 070  
info@dspmindustria.it www.dspmindustria.it