

# Model 4803A Accelerometer



MEMS Triaxial Accelerometer  
Hermetically Sealed  
Signal Conditioned Output  
Advanced Temp Compensation



The **Model 4803A** is a low noise triaxial accelerometer in a rugged, welded stainless steel package. The silicon MEMS accelerometer incorporates integral temperature compensation that provides a stable output over a wide temperature range from  $-55^{\circ}\text{C}$  to  $+125^{\circ}\text{C}$ . Offered in ranges from  $\pm 2$  to  $\pm 500\text{g}$ , the model 4803A accelerometer also provides a wide bandwidth from DC to 2000Hz for both static and dynamic measurements.

## FEATURES

- $\pm 2\text{g}$  to  $\pm 500\text{g}$  Dynamic Range
- Amplified Output
- 8-36Vdc Excitation Voltage
- Hermetically Sealed
- Gas Damped MEMS Element
- Detachable Cable
- Temperature Compensated
- Low Transverse Sensitivity

## APPLICATIONS

- Low Frequency Monitoring
- Transportation
- Flight Testing
- Machine Control
- Road Vehicle Testing
- Trains

## dimensions

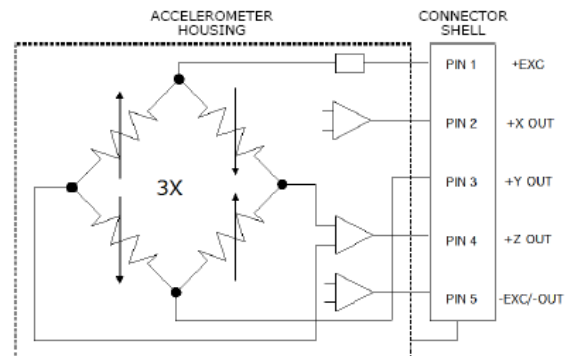
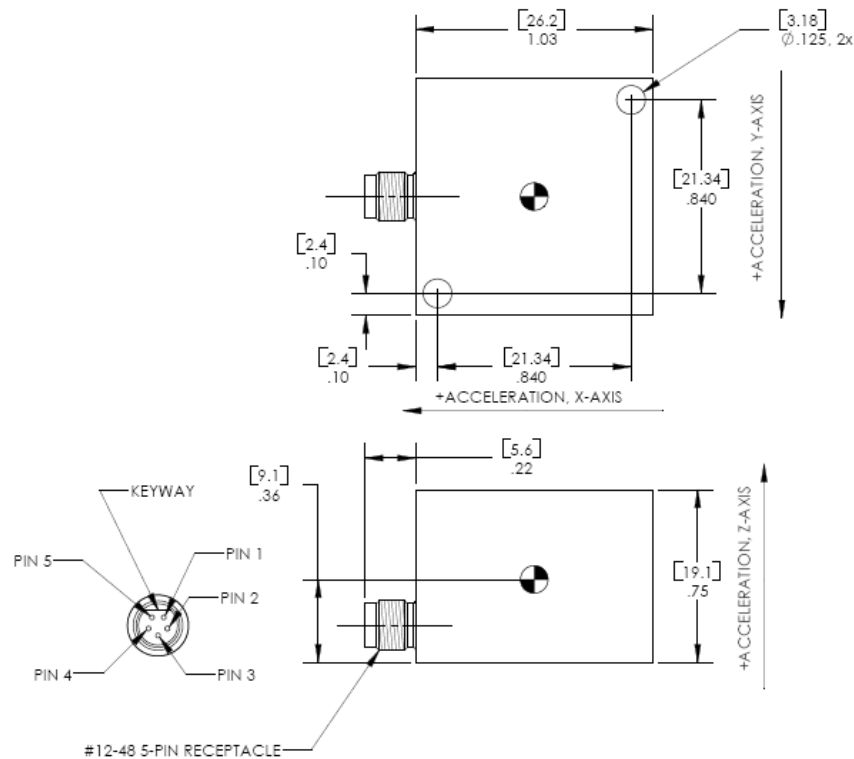

# Model 4803A Accelerometer

## performance specifications

All values are typical at +24°C, 100Hz and 12Vdc excitation unless otherwise stated. Measurement Specialties reserves the right to update and change these specifications without notice. Standard product parameters are described in PSC-1004 for Plug & Play DC Accelerometers.

### Parameters

#### DYNAMIC

	±2	±5	±10	±20	±50	±100	±200	±500	Notes
Range (g)									
Sensitivity (mV/g)	1000	400	200	100	40	20	10	4	
Frequency Response (Hz)	0-150	0-250	0-400	0-600	0-800	0-1000	0-1000	0-1200	±5
Frequency Response (Hz)	0-400	0-500	0-600	0-1000	0-1400	0-1600	0-2000	0-2000	±1dB
Natural Frequency (Hz)	700	800	1000	1500	4000	6000	8000	10000	
Non-Linearity (%FSO)	±1.0	±1.0	±1.0	±1.0	±1.0	±1.0	±1.0	±1.0	
Transverse Sensitivity (%)	<3	<3	<3	<3	<3	<3	<3	<3	<1 Typical
Damping Ratio	0.7	0.7	0.7	0.7	0.7	0.7	0.6	0.5	
Shock Limit (g)	5000	5000	5000	5000	5000	5000	5000	5000	
Residual Noise (µV RMS)	500	300	300	350	400	400	400	400	Passband
Spectral Noise (µg/√Hz)	35	38	75	132	316	516	1033	2582	Passband

#### ELECTRICAL

Zero Acceleration Output (mV)	±50								Differential
Excitation Voltage (Vdc)	8 to 36								
Excitation Current (mA)	<15								
Bias Voltage (Vdc)	2.5								
Output Resistance (Ω)	<100								
Insulation Resistance (MΩ)	>100								@100Vdc
Turn On Time (msec)	<100								
Ground Isolation	Isolated from Mounting Surface								

#### ENVIRONMENTAL

Thermal Zero Shift (%FSO/°C)	±0.008								Typical
Thermal Sensitivity Shift (%/°C)	±0.010								Typical
Operating Temperature (°C)	-55 to 125								
Compensated Temperature (°C)	-40 to 100								
Storage Temperature (°C)	-55 to 125								
Humidity	Hermetically Sealed, IP67 <sup>1</sup>								

#### PHYSICAL

Case Material	Stainless Steel
Weight (grams)	56
Mounting	2x #4 or M3 Screws
Mounting Torque	6 lb-in (0.7 N-m)

<sup>1</sup> Mating cable needs to also have minimum IP67 rating and be properly sealed to accel connector in accordance with IEC 60529.

**Calibration supplied:** CS-FREQ-0100 NIST Traceable Amplitude Calibration from 20Hz to ±5% Frequency Response Limit

**Supplied accessories:** AC-D02995 2x #4-40 (7/8" length) Socket Head Cap Screw and Washer

**Optional accessories:** 350-XXX Cable Assembly, #30 AWG, -54 to +121°C (XXX designates length in inches, 5ft standard)  
 101 Three Channel DC Signal Conditioner Amplifier  
 AC-D02744 Adhesive Mounting Adaptor

The information in this sheet has been carefully reviewed and is believed to be accurate; however, no responsibility is assumed for inaccuracies. Furthermore, this information does not convey to the purchaser of such devices any license under the patent rights to the manufacturer. Measurement Specialties, Inc. reserves the right to make changes without further notice to any product herein. Measurement Specialties, Inc. makes no warranty, representation or guarantee regarding the suitability of its product for any particular purpose, nor does Measurement Specialties, Inc. assume any liability arising out of the application or use of any product or circuit and specifically disclaims any and all liability, including without limitation consequential or incidental damages. Typical parameters can and do vary in different applications. All operating parameters must be validated for each customer application by customer's technical experts. Measurement Specialties, Inc. does not convey any license under its patent rights nor the rights of others.

# Model 4803A Accelerometer

## performance specifications

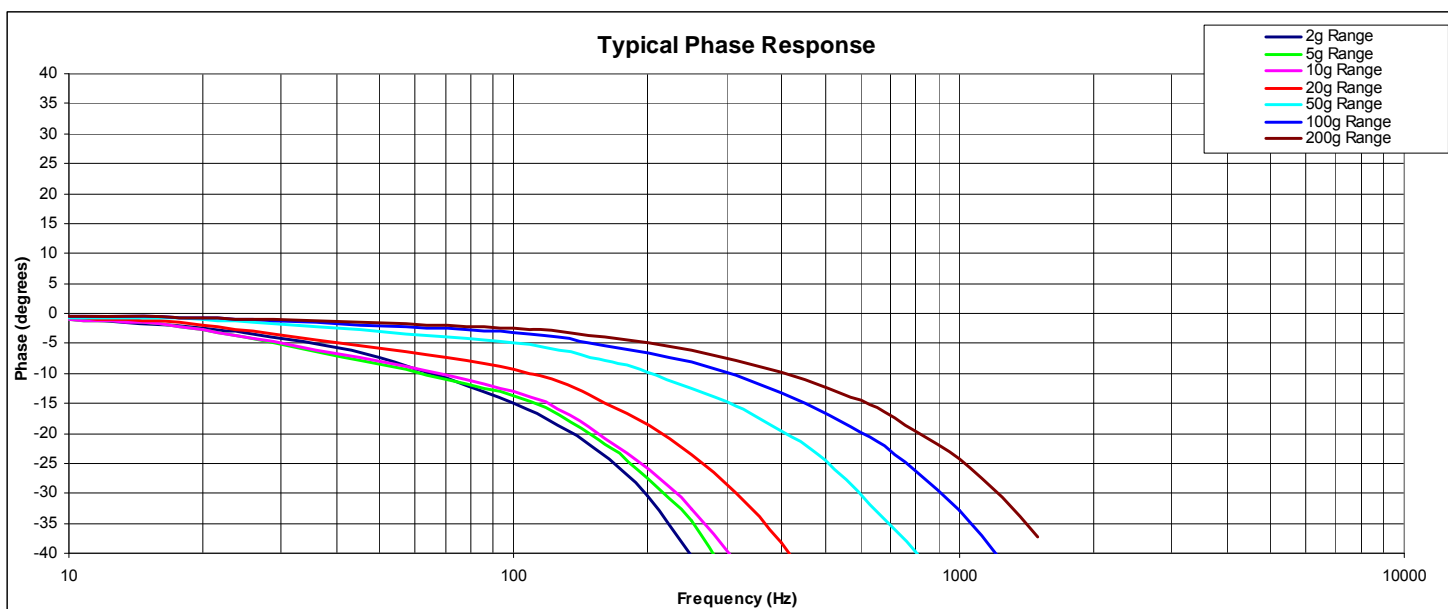
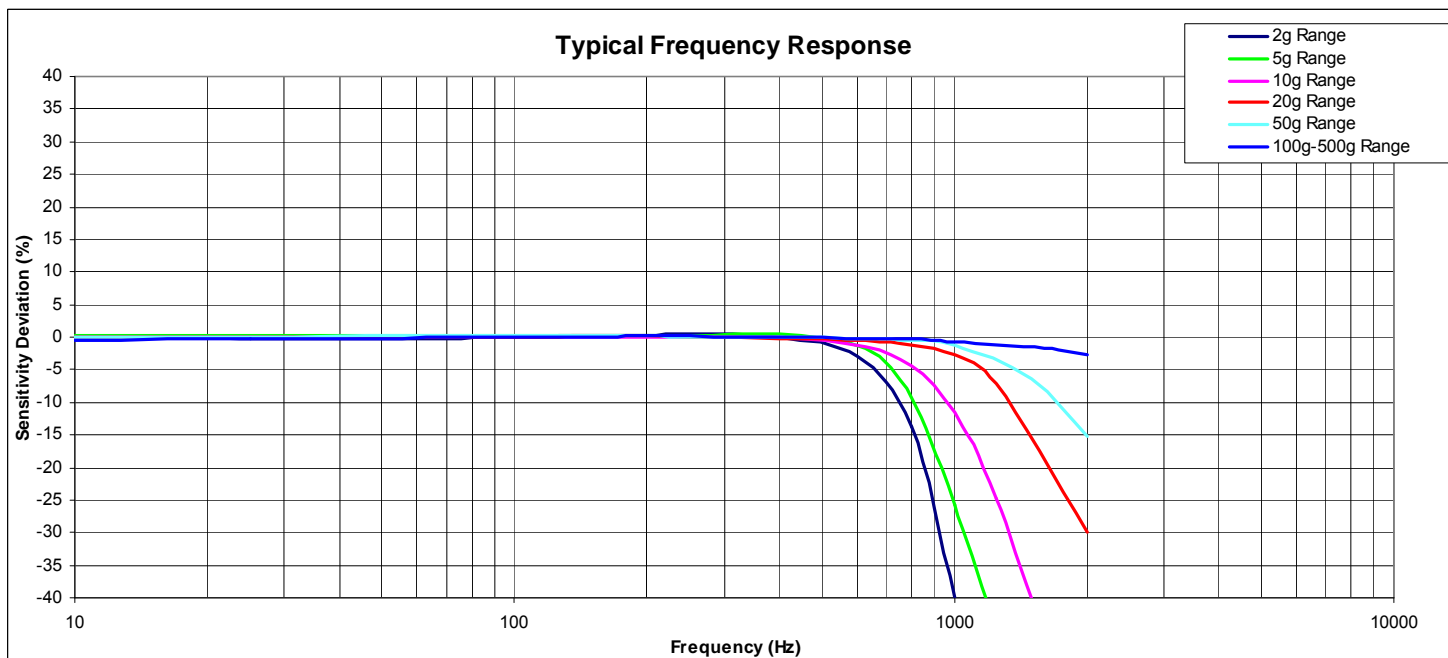

## ordering info

PART NUMBERING Model Number+Range

4803A-GGGG

|  
| \_\_\_\_\_ Range (0010 is 10g)

Example: 4803A-0010  
Model 4803A, 10g