

Model 5250-2 Current Regulated Power Supply

DESCRIPTION

The 5250 is an open frame, current-regulated power supply that is designed for use with Magtrol's Hysteresis Brakes and Clutches. With regulated current, torque drift caused by temperature changes within the brake coil is eliminated. The 5250 is a solid-state control that provides smooth application of current from zero to maximum. Braking control is enabled by either by a 10-turn potentiometer, or by an external 0-5 VDC control signal.

SPECIFICATIONS

Brake Voltage	24 VDC		
Current Ranges	0-200 mA, 0-500 mA, 0-1000 mA		
Current Regulation	±1% Full Scale		
Braking Control	10-turn potentiometer or 0-5 VDC		
Current Monitor Output	0-200 mV DC		
Line Fuse (5 × 20 mm)	120 V:	UL/CSA 1.0 A	250V SB
	240 V:	IEC 0.4 A	250V T
Brake Fuse (5 × 20 mm)		UL/CSA 1.25 A	250V SB
		IEC 1.00 A	250V T
Power Requirements	100 VA		
Voltage Requirements	120/240 VAC 50/60 Hz		
Max. Compliance Voltage	45 VDC		

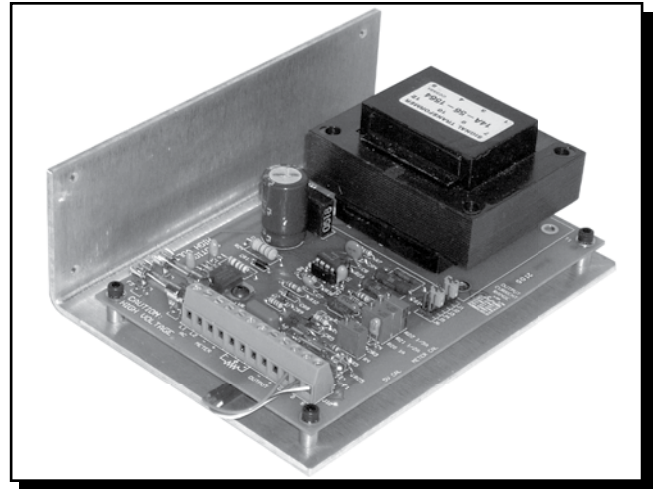

SYSTEM CONFIGURATION

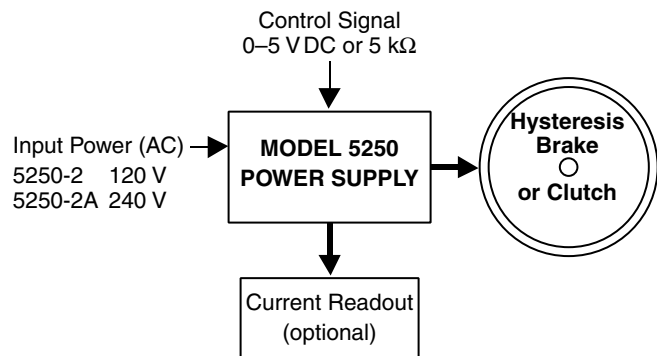

ORDERING INFORMATION

5250-2	Current Regulated Power Supply 120 VAC
5250-2A	Current Regulated Power Supply 240 VAC

Due to the continual development of our products, we reserve the right to modify specifications without forewarning.

