

MAGTROL

Model 6510e

Single-Phase Power Analyzer



User's Manual

Purchase Record

Please record all model numbers and serial numbers of your Magtrol equipment, along with the general purchase information. The model number and serial number can be found on either a silver identification plate or white label affixed to each unit. Refer to these numbers whenever you communicate with a Magtrol representative about this equipment.

Model Number: _____

Serial Number: _____

Purchase Date: _____

Purchased From: _____

While every precaution has been exercised in the compilation of this document to ensure the accuracy of its contents, Magtrol, Inc. assumes no responsibility for errors or omissions. Additionally, no liability is assumed for any damages that may result from the use of the information contained within this publication.

COPYRIGHT

Copyright ©2001-2005 Magtrol, Inc. All rights reserved.

Copying or reproduction of all or any part of the contents of this manual without the express permission of Magtrol is strictly prohibited.

TRADEMARKS

LabVIEW™ is a trademark of National Instruments Corporation.

National Instruments™ is a trademark of National Instruments Corporation.

Windows® is a registered trademark of Microsoft Corporation.

Safety Precautions



1. Make sure that all Magtrol dynamometers and electronic products are earth-grounded, to ensure personal safety and proper operation.
2. Securely ground the 6510e Power Analyzer case by connecting a good earth ground at the ground stud located on the rear panel of the unit. Use a number 12 AWG, or larger wire.
3. Check line voltage before operating.
4. Make sure that dynamometers and motors under test are equipped with appropriate safety guards.

Revisions To This Manual

The contents of this manual are subject to change without prior notice. Should revisions be necessary, updates to all Magtrol User's Manuals can be found at Magtrol's web site at www.magtrol.com/support/manuals.htm.

Please compare the date of this manual with the revision date on the web site, then refer to the manual's Table of Revisions for any changes/updates that have been made since this edition.

REVISION DATE

Preliminary Manual, Revision F – November 2005

TABLE OF REVISIONS

Date	Edition	Change	Section(s)
11/03/05	Preliminary Manual, Rev. F	Corrected time it takes for a new input to fully average (0.07323388 ms → 73.23388 ms).	4.2.1.2 & 4.2.2.2
11/03/05	Preliminary Manual, Rev. F	Updated crest factor and display range ratings.	1.3
08/10/05	Preliminary Manual, Rev. E	External sensor input maximum voltage from ±10 V to ±1 V AC/DC	1.3, 2.5
09/30/03	Preliminary Manual, Rev. D	Correction: Line voltage - no setup required.	3.1.1
06/19/03	Preliminary Manual, Rev. C	Added configuration commands IS and IC to start/clear average mode.	5.6.1
06/19/03	Preliminary Manual, Rev. C	Added data output command OAVE to retrieve displayed values.	5.6.2
06/19/02	Preliminary Manual, Rev. B	Added analog output option information to data sheet.	1.3
05/20/02	Preliminary Manual, Rev. A	Changed mV/A to A/mV in External Sensor Scale Factor Setup Menu graphic	3.3.3.2
05/20/02	Preliminary Manual, Rev. A	Updated units and value range of SE1m2<terminator> command code	5.6.1

Table of Contents

SAFETY PRECAUTIONS	I
REVISIONS TO THIS MANUAL	II
REVISION DATE.....	II
TABLE OF REVISIONS.....	II
TABLE OF CONTENTS	III
TABLE OF FIGURES	VI
PREFACE.....	VII
PURPOSE OF THIS MANUAL	VII
WHO SHOULD USE THIS MANUAL.....	VII
MANUAL ORGANIZATION.....	VII
CONVENTIONS USED IN THIS MANUAL.....	VIII
1. INTRODUCTION	1
1.1 UNPACKING YOUR 6510e POWER ANALYZER.....	1
1.2 NEW FEATURES OF THE 6510e POWER ANALYZER.....	1
1.3 DATA SHEET.....	2
2. CONTROLS.....	5
2.1 FRONT PANEL.....	5
2.2 FRONT PANEL CONTROLS AND BUTTONS	5
2.2.1 ENABLING SECONDARY FUNCTIONS.....	6
2.2.2 USING FRONT PANEL CONTROLS AND BUTTONS	6
2.3 VACUUM FLUORESCENT DISPLAY (VFD).....	8
2.3.1 CONTRAST SETTINGS.....	8
2.3.2 DISPLAY GUIDE.....	9
2.4 REAR PANEL.....	10
2.5 REAR PANEL INPUTS AND OUTPUTS.....	10
3. INSTALLATION/CONFIGURATION.....	13
3.1 POWERING UP THE 6510e.....	13
3.1.1 LINE VOLTAGE.....	13
3.1.2 SELF-TEST.....	13
3.1.3 MAIN MENU	14
3.2 PROTECTING YOUR 6510e.....	15
3.2.1 TRANSIENT OVERLOADS.....	15
3.2.2 CURRENT OVERLOAD	15
3.2.3 SURGE PROTECTION	15
3.2.4 CIRCUIT BREAKERS.....	16
3.3 TESTING INSTRUMENTATION SETUP.....	17
3.3.1 WIRING MODE.....	17
3.3.2 MEASUREMENT FILTER	18
3.3.3 EXTERNAL SENSOR	19
3.3.4 AMP SCALING.....	21
3.3.5 VOLTS SCALING.....	23

3.3.6	PHASE SETUP	24
3.3.7	SPECIAL FUNCTIONS	25
4.	OPERATING PRINCIPLES	27
4.1	ANALOG PROCESSING	27
4.1.1	VOLTS	27
4.1.2	AMPS	28
4.1.3	EXTERNAL SHUNT	29
4.2	DIGITAL PROCESSING	29
4.2.1	AC DETAILS	30
4.2.2	DC DETAILS	32
4.2.3	ROUND-OFF ERROR	34
4.3	MEASUREMENT MODES	34
4.3.1	PEAK	34
4.3.2	PEAK HOLD / INRUSH CURRENT	35
4.3.3	DC	35
4.3.4	RMS	36
4.3.5	CREST FACTOR	36
4.4	MEASUREMENT METHODS	36
4.4.1	CYCLE-BY-CYCLE MODE	36
4.4.2	CONTINUOUS MODE	36
5.	COMPUTER CONTROLLED OPERATION	37
5.1	ABOUT THE GPIB INTERFACE	37
5.1.1	INSTALLING THE GPIB/IEEE-488 CONNECTOR CABLE	37
5.1.2	CHANGING THE GPIB PRIMARY ADDRESS	37
5.2	ABOUT THE RS-232 INTERFACE	38
5.2.1	CONNECTION	38
5.2.2	COMMUNICATION PARAMETERS	39
5.2.3	BAUD RATE	39
5.3	CHECKING THE 6510e-TO-PC CONNECTION	39
5.4	DATA FORMAT	40
5.4.1	OT EXAMPLE	40
5.4.2	OE EXAMPLE	41
5.4.3	OA/OV/OW/OF EXAMPLE	41
5.5	PROGRAMMING	41
5.5.1	DATA TERMINATION CHARACTERS	41
5.6	6510e COMMUNICATION COMMANDS	42
5.6.1	CONFIGURATION COMMANDS	42
5.6.2	DATA OUTPUT COMMANDS	44
6.	CALIBRATION	45
6.1	CLOSED-BOX CALIBRATION	45
6.2	CALIBRATION SCHEDULE	45
6.3	CALIBRATION COMMANDS	45
6.4	BASIC CALIBRATION PROCESS	46
7.	OPTIONAL FEATURES	48

7.1 ANALOG OUTPUTS	48
7.1.1 SPECIFICATIONS	48
7.1.2 CHANNEL ASSIGNMENTS.....	48
7.1.3 HARDWARE CONNECTION	49
7.1.4 SOFTWARE CONFIGURATION	49
7.1.5 CALIBRATION	50
8. TROUBLESHOOTING.....	52
APPENDIX A: SCHEMATICS	53
A.1 MAIN BOARD - DSP, RAM, FLASH.....	53
A.2 MAIN BOARD - INPUT/OUTPUT, GPIB, RS-232.....	54
A.3 MAIN BOARD - FPGA	55
A.4 INPUT MODULE - CURRENT	56
A.5 INPUT MODULE - VOLTAGE	57
A.6 KEY PAD	58
A.7 ANALOG OUTPUT.....	59
GLOSSARY.....	63
INDEX.....	64
SERVICE INFORMATION	66
RETURNING MAGTROL EQUIPMENT FOR REPAIR AND/OR CALIBRATION	66
RETURNING EQUIPMENT TO MAGTROL, INC. (UNITED STATES).....	66
RETURNING EQUIPMENT TO MAGTROL SA (SWITZERLAND)	66

TABLE OF FIGURES

2. CONTROLS	
Figure 2-1 Front Panel	5
Figure 2-2 Secondary Function Menu.....	6
Figure 2-3 Device Setup Menu.....	9
Figure 2-4 Rear Panel	10
Figure 2-5 Input Module	10
Figure 2-6 RS-232C Interface	11
Figure 2-7 GPIB/IEEE-488 Interface	11
3. INSTALLATION/CONFIGURATION	
Figure 3-1 Program Download Display.....	13
Figure 3-2 Title Display	13
Figure 3-3 Revision Display.....	14
Figure 3-4 Phase Main Menu.....	14
Figure 3-5 Custom Main Menu	14
Figure 3-6 Transient Voltage Suppression.....	16
Figure 3-7 Single-Phase, Two-Wire Wiring Schematic.....	17
Figure 3-8 Single-Phase, Two-Wire Wiring Connection	17
Figure 3-9 Sensor Substituton Wiring Schematic.....	19
Figure 3-10 Sensor Substitution Wiring Connection.....	19
Figure 3-11 External Sensor Scale Factor Setup Menu	20
Figure 3-12 Current/Potential Transformer Connection.....	21
Figure 3-13 Amp Scaling Setup Menu.....	21
Figure 3-14 Amp/Volt Scaling Activated	22
Figure 3-15 Volt Scaling Setup Menu.....	23
Figure 3-16 Cycle-by-Cycle Mode	24
Figure 3-17 Hold Mode.....	25
Figure 3-18 Average Mode	25
Figure 3-19 Peak Hold Clear Display.....	26
Figure 3-20 Custom Display	26
4. OPERATING PRINCIPLES	
Figure 4-1 Peak Example.....	34
Figure 4-2 Peak Hold/Inrush Current Example	35
Figure 4-3 Crest Factor Example.....	36
5. COMPUTER CONTROLLED OPERATION	
Figure 5-1 GPIB Installation	37
Figure 5-2 GPIB Address Setup Menu	38
Figure 5-3 RS-232 Interface.....	38
Figure 5-4 Cable Connection Using Null Modem.....	38
Figure 5-5 RS-232 Baud Rate Setup Menu	39
6. CALIBRATION	
Figure 6-1 Calibration/Verification Test Setup.....	46
Figure 6-2 Calibration Mode Enabled.....	46
7. OPTIONAL FEATURES	
Figure 7-1 Analog Output	48
Figure 7-2 Analog Output Setup Menu	49

Preface

PURPOSE OF THIS MANUAL

This manual contains all the information required for the installation and general use of the Model 6510e Power Analyzer. To achieve maximum capability and ensure proper use of the instrument, please read this manual in its entirety before operating. Keep the manual in a safe place for quick reference whenever a question should arise.

WHO SHOULD USE THIS MANUAL

This manual is intended for those operators who are planning to use the Model 6510e Power Analyzer for power measurement purposes either as a stand-alone instrument or in conjunction with any Magtrol Hysteresis, Eddy-Current or Powder Brake Dynamometer, any Magtrol Dynamometer Controller and M-TEST Motor Testing Software.

MANUAL ORGANIZATION

This section gives an overview of the structure of the manual and the information contained within it. Some information has been deliberately repeated in different sections of the document to minimize cross-referencing and to facilitate understanding through reiteration.

The structure of the manual is as follows:

- Chapter 1: INTRODUCTION - Contains the technical data sheet for the 6510e Power Analyzer, which describes the unit and provides its mechanical and electrical characteristics.
- Chapter 2: CONTROLS - Description of the elements located on the front and rear panels of the unit.
- Chapter 3: INSTALLATION/CONFIGURATION - Provides information needed for setup of the 6510e including wiring mode, measurement filter, external sensor, amp scaling and volt scaling along with phase setup instructions and special functions available.
- Chapter 4: OPERATING PRINCIPLES - Information pertaining to theory of operation including analog processing, digital processing, measurement modes and measurement methods.
- Chapter 5: COMPUTER CONTROLLED OPERATION - How to run a test when the 6510e is used with a PC. Includes information on IEEE-488 and RS-232 Interface, data format, programming and command set.
- Chapter 6: CALIBRATION - Provides recommended calibration schedules along with step-by-step instructions for the calibration procedure.
- Chapter 7: OPTIONAL FEATURES - Provides information regarding various optional features available with the 6510e including analog outputs.
- Chapter 8: TROUBLESHOOTING - Solutions to common problems encountered during setup and testing.
- Appendix A: SCHEMATICS - For the main board, input modules, key pad and analog output.
- Glossary: List of abbreviations and terms used in this manual, along with their definitions.

CONVENTIONS USED IN THIS MANUAL

The following symbols and type styles may be used in this manual to highlight certain parts of the text:



Note: This is intended to draw the operator’s attention to complementary information or advice relating to the subject being treated. It introduces information enabling the correct and optimal functioning of the product to be obtained.



CAUTION: THIS IS USED TO DRAW THE OPERATOR’S ATTENTION TO INFORMATION, DIRECTIVES, PROCEDURES, ETC. WHICH, IF IGNORED, MAY RESULT IN DAMAGE BEING CAUSED TO THE MATERIAL BEING USED. THE ASSOCIATED TEXT DESCRIBES THE NECESSARY PRECAUTIONS TO TAKE AND THE CONSEQUENCES THAT MAY ARISE IF THE PRECAUTIONS ARE IGNORED.



WARNING! THIS INTRODUCES DIRECTIVES, PROCEDURES, PRECAUTIONARY MEASURES, ETC. WHICH MUST BE EXECUTED OR FOLLOWED WITH THE UTMOST CARE AND ATTENTION, OTHERWISE THE PERSONAL SAFETY OF THE OPERATOR OR THIRD PARTY MAY BE PUT AT RISK. THE READER MUST ABSOLUTELY TAKE NOTE OF THE ACCOMPANYING TEXT, AND ACT UPON IT, BEFORE PROCEEDING FURTHER.

1. Introduction

1.1 UNPACKING YOUR 6510e POWER ANALYZER

Your 6510e Power Analyzer was packaged in reusable, shock resistant packing material that will protect the instrument during normal handling.

1. Make sure the carton contains the following:

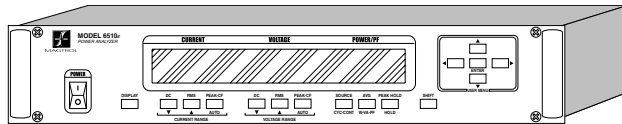

6510e Single-Phase Power Analyzer

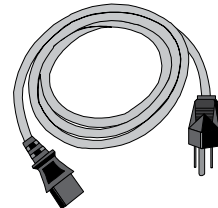

Line cord

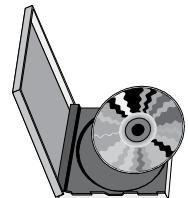

Magtrol
User Manual
CD-Rom

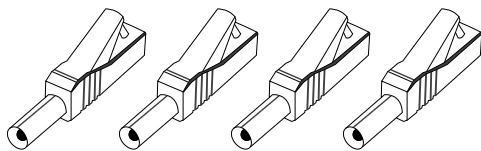

Banana Jack Connectors (4 each per phase)

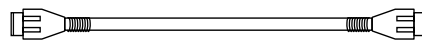

Isolated BNC Sensor
Connectors (1 each per phase)

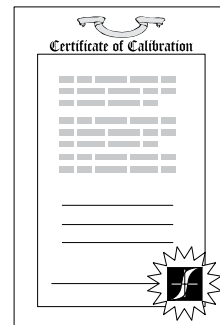

Calibration Certificate

2. Inspect the contents for any evidence of damage in shipping. In the event of shipping damage, immediately notify the carrier and Magtrol's Customer Service Department.



Note: Save all shipping cartons and packaging material for reuse when returning the instrument for calibration or servicing.

1.2 NEW FEATURES OF THE 6510e POWER ANALYZER

Magtrol's new Model 6510e Single-Phase Power Analyzer is an upgraded version of the 6510. The new features that make the unit unique include:

- **Analog Outputs:** Plug-in module that provides 12 channels of analog output corresponding to volts, amps and watts.
- **Peak Hold:** Allows the unit to store the highest value read since the last peak hold was cleared. Values can include amps, watts and volts in any preferred combination.
- **Average:** Will average the volts, amps and watts over the period that the average function is enabled.
- **Custom Readout:** Display can be configured to present data in any desired format.

1.3 DATA SHEET

Models 6510e and 6530 Power Analyzers

FEATURES

- **Single/Three-Phase Capabilities:** For single (6510e) or three-phase (6530) power measurements
- **Ranges:** Up to 600 V_{rms} @ 20 A continuous duty
- **Interfaces:** RS-232 & IEEE-488
- **Data Transfer Rates:** Up to 100 per second
- **Accuracy:** Up to 0.1%
- **Vacuum Fluorescent Display:** High-quality, easy-to-read, customizable readout displays volts, amps, power and power factor
- **Measurement:** Continuous or cycle-by-cycle
- **Bandwidth:** DC up to 100 kHz
- **Input Power:** Accepts 120/240 V_{rms}, 60/50 Hz power at 20 VA max
- **Auto Ranging:** Automatically scales instrument for most accurate range
- **Isolation:** 1000 V_{rms} to earth, 750 V_{rms} line-to-line
- **Average:** Displays running average of amps, volts and watts
- **Peak Hold:** Stores the highest value read. Values can include amps, watts and volts in any combination
- **Analog Outputs:** Plug-in module provides 12 channels of analog output corresponding to volts, amps and watts
- **External Shunt Input**
- **Calibration Certificate:** NIST Traceable
- **Rack Mounting:** 19" (482.6 mm) with handles



DESCRIPTION

The Magtrol 6510e and 6530 Power Analyzers are easy-to-use instruments ideal for numerous power measurement applications. From DC to 100 kHz AC, the 6510e/6530 measures volts, amps, watts, volt-amps, frequency, crest factor, V_{peak}, A_{peak} and power factor in one convenient display. They may be used either as stand-alone instrument or in conjunction with any Magtrol Hysteresis, Eddy-Current or Powder Brake Dynamometer; any Magtrol Dynamometer Controller and M-TEST Software for more demanding motor test applications.

APPLICATIONS

- Motors and Drives
- Lighting Fixtures/Ballasts
- Office Equipment
- Household Appliances
- Power Tools
- HVAC Equipment
- Calibration of Test and Measuring Instruments
- Switching Power Supplies
- Power Inverters
- Transformers

The 6510e's/6530's data transfer rate makes it ideal for both static and dynamic tests.

SYSTEM CONFIGURATIONS

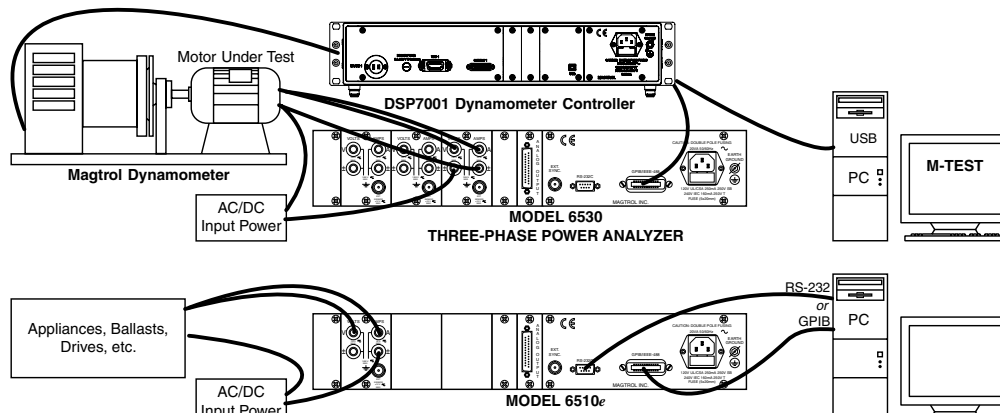

Specifications

6510e/6530

	VOLTAGE INPUT	CURRENT INPUT	EXTERNAL SENSOR INPUT	POWER
Ranges	30 V, 150 V, 300 V, 600 V	1 A, 5 A, 10 A, 20 A	50 mV, 250 mV, 500 mV, 1 V	---
Maximum Voltage	750 V AC/DC terminal (V) to terminal (±) and 1000 V AC/DC terminal to earth ground	1000 V AC/DC terminal to ground	±1 V AC/DC	---
Crest Factor	1.7 @ full scale input	2.7 @ full scale input	2.4 @ full scale input	---
Impedance	2 mΩ	12 mΩ	17 KΩ	---
Display Range	5 digits with 1 mV resolution	5 digits with 1 mA resolution	5 digits with 1 μV resolution	5 digits with 1 mW resolution
ACCURACY				
DC	±(0.1% Reading + 0.2% Range)			0.4% of VA range
5 Hz – 500 Hz	±(0.1% Reading + 0.1% Range)			0.2% of VA range
500 Hz – 10 kHz	±((0.015 × F(kHz)% Reading) + 0.3% Range)			0.6% of VA range
10 kHz – 100 kHz	±((0.015 × F(kHz)% Reading) + 0.3% Range)			0.6% + (0.03% × F(kHz)% of VA range)
> 100 kHz	N/A (measurement band limited to DC–100 kHz)			

FREQUENCY	
Source	V ₁ , A ₁ , V ₂ , A ₂ , V ₃ , A ₃ , LINE or EXT (For V _x and A _x , source input must be >10% of range setting)
Accuracy	20 Hz to 500 Hz; 0.05%
EXT. Input	BNC non-isolated, earth ground referenced
Input Impedance	100 kΩ
Voltage Level	TTL / CMOS
Maximum Voltage	50 V

DIMENSIONS		
Width	19.0 in	483 mm
Height	3.5 in	89 mm
Depth with handles	12.4 in	315 mm
Weight	12.97 lb	5.88 kg

FRONT PANEL

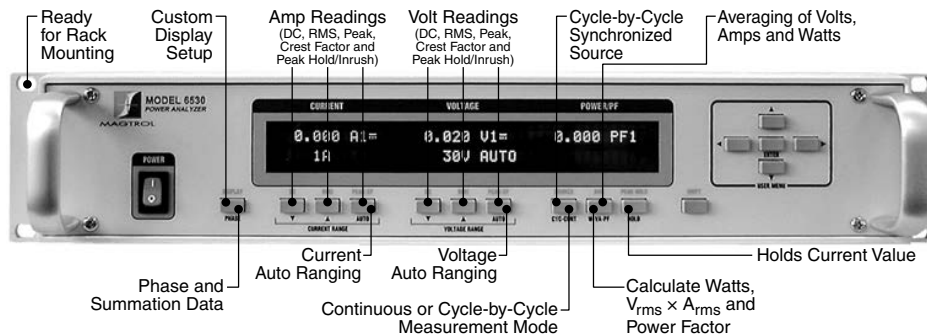

REAR PANEL

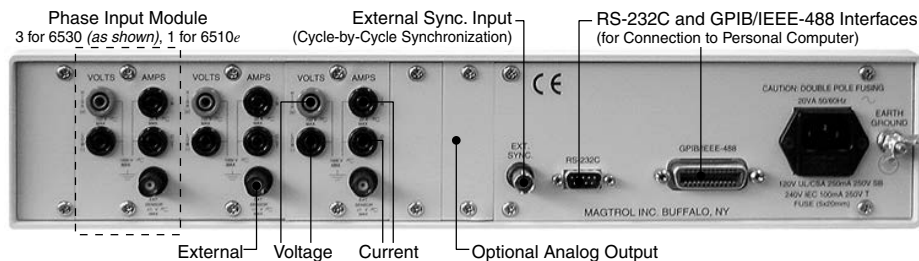

Options and Accessories

6510e/6530

ANALOG OUTPUT OPTION

The Analog Output is a plug-in module designed specifically for use with the 6510e Single-Phase Power Analyzer and 6530 Three-Phase Power Analyzer. It provides up to 12 outputs (3 for the 6510e, 12 for the 6530) for analog output corresponding to volts, amps and watts. Each output is capable of, and calibrated to, ± 10 volts. With the analog output option, the user may apply a scale factor to all outputs. Amps scaling is applied to all amp outputs, volts scaling is applied to all volt outputs and watts scaling is applied to all watt outputs.

Other features include:

- Simple Installation: Plug-in module automatically configures power analyzer for operation
- Frequent Output Updates: Updates every 5 milliseconds
- Output Short Protected
- Factory Calibrated: Calibration data/values stored on board (EEPROM)
- Industry Standard 25-Pin Connection

The Analog Output can be used along with a 6510e or 6530 Power Analyzer to output information to a strip recorder or interface with a data acquisition system. The Analog Output is also used as a safety feature to help trigger alarm events.

SPECIFICATIONS	
Resolution	14 bits
Temperature Coefficient	4 ppm FSR/°C (typical), 20 ppm FSR/°C (maximum)
Output Range	± 10 V maximum
Number of Outputs	3 (6510e) 12 (6530)
Basic Accuracy	3 least significant bits
Output Update Rate (all channels)	200 samples/second (5 ms)

ORDERING INFORMATION

- 6510e** Single-Phase Power Analyzer
- 6510e-01** Single-Phase Power Analyzer with Analog Output Option
- 6530** Three-Phase Power Analyzer
- 6530-01** Three-Phase Power Analyzer with Analog Output Option

EXTERNAL SHUNTS/SENSORS

If currents continuously reach above 20 amps, an external sensor must be used. Magtrol offers three different types of external shunts for use with Magtrol Models 6510e or 6530 High-Speed Power Analyzers.

Available Models		
Type	P/N	Amps
HA	004640	50
HA	004641	100
HA	004642	150
HA	004643	200
HA	004644	250
HA	004645	300
HA	004646	400
HA	004647	500
LAB	004648	750
LAB	004649	1000
FL	005214	2000
FL	005286	3000

The HA Series shunt, designed for power cable hook-up utilizing 3/8-16 screws, has an insulating base and can be mounted on conductive surfaces. The LAB Series shunt also comes with an insulating base, along with thumb screws for the power leads and knurled nuts on the sensing terminals. The FL Series is a relatively small bus, bar-mounted shunt with large end blocks. The comparatively large end blocks and short spacing aid in cooling and allow the shunt to operate in more extreme environments. All shunts are calibrated on equipment with current certifications traceable to N.I.S.T.

SPECIFICATIONS			
	HA Series	LAB Series	FL Series
Rated Current	50 to 500 A	750 to 1000 A	2000 to 3000 A
Output	50 mV		
Bandwidth	DC to 60 Hz		
Accuracy	$\pm 0.25\%$ ($\pm 0.1\%$ accuracy with calibration certificate is available for an additional cost)		
Operating Temperature	For optimum accuracy, temperature of shunt should be 30 °C to 70 °C		

Sensor Substitution Wiring Connection

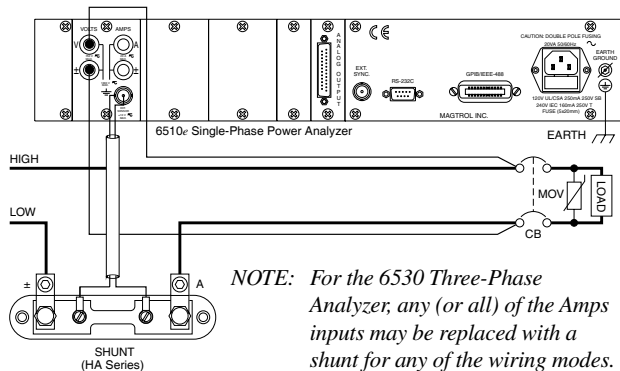

Due to the continual development of our products, we reserve the right to modify specifications without forewarning.

2. Controls

2.1 FRONT PANEL

The front panel provides a power switch, sixteen control buttons and a Vacuum Fluorescent Display (VFD).

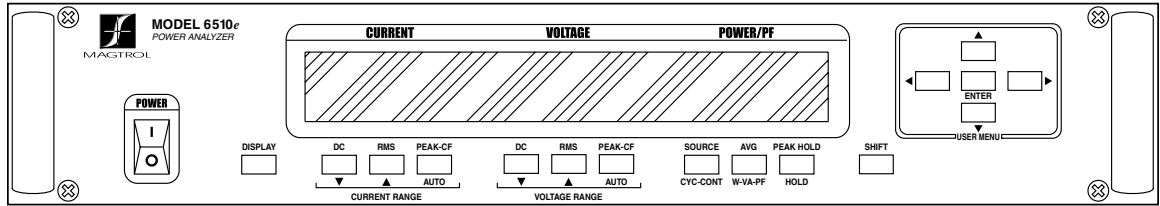

Figure 2-1 Front Panel

2.2 FRONT PANEL CONTROLS AND BUTTONS

The front panel controls and buttons, from left to right, are:

- Power switch
- Display button
- Nine double-function control buttons:

Primary Function	Secondary Function
▼ CURRENT RANGE	DC (current)
▲ CURRENT RANGE	RMS (current)
AUTO CURRENT RANGE	PEAK-CF (current)
▼ VOLTAGE RANGE	DC (voltage)
▲ VOLTAGE RANGE	RMS (voltage)
AUTO VOLTAGE RANGE	PEAK-CF (voltage)
CYC-CONT	SOURCE
W-VA-PF	AVG
HOLD	PEAK HOLD

- SHIFT - enables secondary functions printed in blue above control buttons
- Five USER MENU buttons
 - Left Arrow ◀
 - Right Arrow ▶
 - Up Arrow ▲
 - Down Arrow ▼
 - ENTER

2.2.1 ENABLING SECONDARY FUNCTIONS

To enable the secondary function of the double-function control buttons:

1. Press the blue SHIFT button and release it. The word “SHIFT” appears in the display:

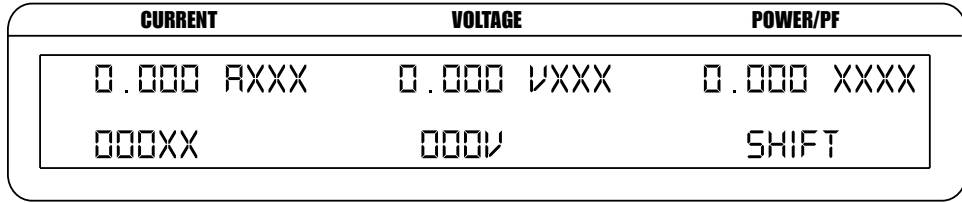

Figure 2–2 Secondary Function Menu

2. Press any control button to enable the function shown in blue letters above the button.

2.2.2 USING FRONT PANEL CONTROLS AND BUTTONS

2.2.2.1 Controls/Single-Function Buttons

Button	To Use	Function
POWER	Press I to turn power ON Press O to turn power OFF.	Turns power ON or OFF.
SHIFT	Press this button and release; then press desired control button.	Enables the function written in blue above control button.
User Menu		
ENTER	Press this button.	Enables/Disables USER MENU.
◀	Press this button.	When USER MENU is enabled, toggles between fields, selections or the digits in a numerical value.
▶	Press this button.	When USER MENU is enabled, toggles between fields, selections or the digits in a numerical value.
▲	Press this button.	When USER MENU is enabled, toggles between selections or increases the selected digit of a numerical value.
▼	Press this button.	When USER MENU is enabled, toggles between selections or decreases the selected digit of a numerical value.

2.2.2.2 Double-Function Buttons

Button	To Use	Function
DISPLAY	Press SHIFT and release; then press this button. (For further instruction, see Section 3.3.7.4 - Custom Display.)	Shows custom display.
PHASE	Press this button.	Toggles through phase 1, 2, 3 and summation.
Current		
DC	Press SHIFT and release; then press this button.	Selects DC amps measurement.
RMS	Press SHIFT and release; then press this button.	Selects RMS amps measurement.
PEAK-CF	Press SHIFT and release; then press this button.	Selects displayed amps measurement. Continue to press SHIFT then PEAK-CF and the displayed values toggle through the following: <ul style="list-style-type: none"> • A_{cf} (amps crest factor readings) • A_{~↑} (amps peak hold/inrush readings) • A_{pk} (amps peak readings)
Current Range		
▼	Press this button.	Decrements amps range.
▲	Press this button.	Increments amps range.
AUTO	Press this button.	Selects/deselects amps auto range.
Voltage		
DC	Press SHIFT and release; then press this button.	Selects DC voltage measurement.
RMS	Press SHIFT and release; then press this button.	Selects RMS voltage measurement.
PEAK-CF	Press SHIFT and release; then press this button.	Selects displayed voltage measurement. Continue to press SHIFT then PEAK-CF and the displayed values toggle through the following: <ul style="list-style-type: none"> • V_{cf} (voltage crest factor readings) • V_{~↑} (voltage peak hold/inrush readings) • V_{pk} (voltage peak readings)
Voltage Range		
▼	Press this button.	Decrements voltage range.
▲	Press this button.	Increments voltage range.
AUTO	Press this button.	Selects/deselects voltage auto range.

Button	To Use	Function
SOURCE	Press SHIFT and release; then press this button.	Selects the signal that the cycle-by-cycle measurement will be synchronized with. Continue to press SHIFT then SOURCE and the source toggles through the following: <ul style="list-style-type: none"> • V1 (voltage input) • A1 (amps input) • EXT (external sync input) • LINE (incoming AC line) NOTE: Selecting SHIFT then SOURCE will automatically switch unit to cycle-by-cycle mode.
CYC-CONT	Press this button.	Selects continuous or cycle-by-cycle measurement method.
AVG	Press SHIFT and release; then press this button.	Enables averaging mode.
W-VA-PF	Press this button.	Selects what calculated value is to be displayed. Continue to press W-VA-PF and the displayed values toggle through the following: <ul style="list-style-type: none"> • W[↑] (inrush watts) • W (watts) • VA ($V_{rms} \times A_{rms}$) • PF (power factor)
PEAK HOLD	Press SHIFT and release; then press this button.	Resets peak hold/inrush values.
HOLD	Press this button.	Holds displayed values until hold is pressed again. NOTE: All internal machine functions will be halted except auto-ranging when the HOLD feature is enabled.

2.3 VACUUM FLUORESCENT DISPLAY (VFD)

The VFD provides information about control functions, phase voltage and current.

Top Row	Bottom Row
Current	Current Range
Voltage	Voltage Range
Power/PF	Source/Status

2.3.1 CONTRAST SETTINGS

The 6510e Power Analyzer is shipped with the Contrast Setting on low in order to prolong display life. If it is necessary to increase the Contrast for improved readability, execute the following steps using the USER MENU located on the front panel of the unit.

1. Press the ENTER button. The display should appear as follows:

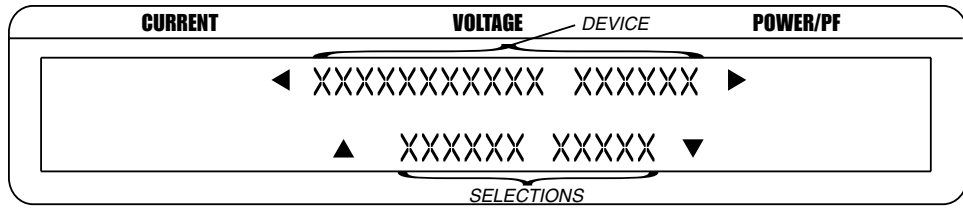

Figure 2–3 Device Setup Menu

2. Press ► and ◀ buttons until "I/O" appears in the display.
3. Press ENTER button.
4. Press ► and ◀ buttons until "DISPLAY BRIGHTNESS" appears in the display.
5. Use the ▲ and ▼ buttons until desired brightness is reached.
6. Press ENTER button to return to main menu.



Note: There are three settings available; low, medium and high. Make sure the lowest possible setting is used to achieve desired result. Using a setting higher than necessary may cause display segments to burn-in over a period of time, resulting in uneven illumination from segment to segment.

2.3.2 DISPLAY GUIDE

Following is a reference for symbols, abbreviations and messages that are used in the 6510e.

Symbol/Abbreviation/Message	Meaning
SHIFT	Shift button was pressed
I/O ERROR	Command not recognized
V	Volts
A	Amps
W	Watts
PF	Power Factor
pk	Peak
cf	Crest Factor
*	Scaling function is activated
⊕	Average function is activated
●	Peak Hold/Inrush function is activated
↑	Peak Hold/Inrush
...	DC
~	RMS (AC+DC)

2.4 REAR PANEL

The rear panel provides connectors and receptacles for connecting to appropriate equipment.

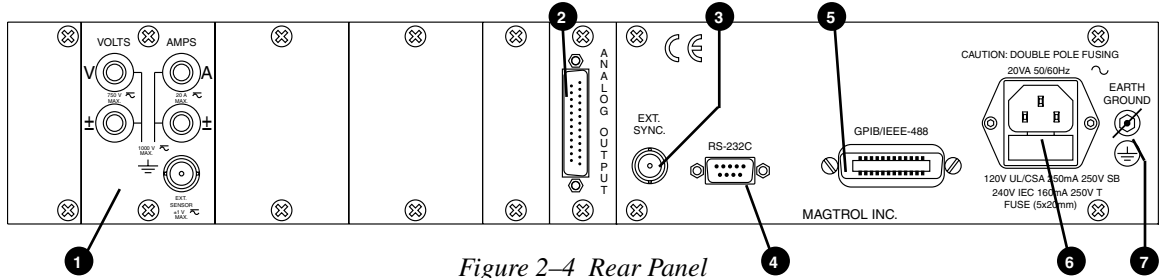

Figure 2-4 Rear Panel

2.5 REAR PANEL INPUTS AND OUTPUTS

1 INPUT MODULE

Contains the Voltage Input, Current Input and External Sensor connector.

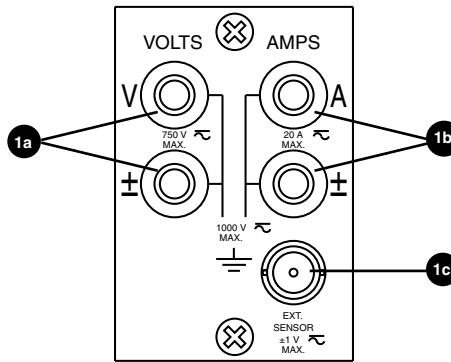

Figure 2-5 Input Module

1a Voltage Input

Connect wires to measure voltage across the load (parallel).



CAUTION: VOLTAGE SHOULD NOT EXCEED 750 V AC/DC TERMINAL (V) TO TERMINAL (±) AND 1000 V AC/DC TERMINAL TO EARTH GROUND.

1b Current Input

Connect wires to measure amps through the load (series).



CAUTION: AMPS SHOULD NOT EXCEED 20 A CONTINUOUS. VOLTAGE SHOULD NOT EXCEED 1000 V AC/DC TERMINAL TO GROUND.

1c External Sensor

Alternate amps input for current sensor or shunt.



CAUTION: VOLTAGE SHOULD NOT EXCEED ±1 V AC/DC.

- 2** ANALOG OUTPUT (optional)

Connects strip chart recorder or data acquisition system, providing 3 analog outputs.

 - Volts
 - Amps
 - Watts

±10 volts = range

See *Section 7.1 – Analog Outputs* for detailed information about this option.

- 3** EXT. SYNC.

Provides alternate method to synchronize the power analyzer with the measured signal in cycle-by-cycle mode.



CAUTION: INPUT IS NOT ISOLATED FROM EARTH GROUND. EXT. SYNC. SHOULD NOT EXCEED 0–5 V DC (TTL/CMOS LEVELS).

- 4** RS-232C

Use this socket for RS-232 connector cable.

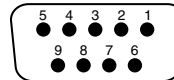

- | | |
|--------|----|
| 1. | 6. |
| 2. TX | 7. |
| 3. RX | 8. |
| 4. | 9. |
| 5. GND | |

Figure 2–6 RS-232C Interface

- 5** GPIB/IEEE-488

Use this socket for GPIB cable (meets IEEE-488 specifications).

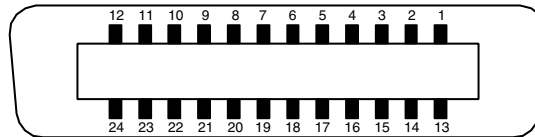

- | | |
|------------|-------------------|
| 1. D1 | 13. D5 |
| 2. D2 | 14. D6 |
| 3. D3 | 15. D7 |
| 4. D4 | 16. D8 |
| 5. E01 | 17. REN |
| 6. DAV | 18. DAV-COM |
| 7. NRFD | 19. NRFD-COM |
| 8. NDAC | 20. NDAC-COM |
| 9. IFC | 21. IFC-COM |
| 10. SRQ | 22. SRQ-COM |
| 11. ATN | 23. ATN-COM |
| 12. SHIELD | 24. SIGNAL GROUND |

Figure 2–7 GPIB/IEEE-488 Interface

6 POWER Attach power cord here.

7 EARTH
GROUND Attach earth ground here.



WARNING: MAKE SURE THAT ALL MAGTROL DYNAMOMETERS AND ELECTRONIC PRODUCTS ARE EARTH-GROUNDED, TO ENSURE PERSONAL SAFETY AND PROPER OPERATION. SECURELY GROUND THE 6510e POWER ANALYZER CASE BY CONNECTING A GOOD EARTH GROUND AT THE GROUND STUD LOCATED ON THE REAR PANEL OF THE UNIT. USE A NUMBER 12 AWG, OR LARGER WIRE.

3. Installation/Configuration



Note: Before installing the 6510e, you should become familiar with the front and rear panels, as outlined in *Chapter 2 – Controls*.

3.1 POWERING UP THE 6510e



WARNING! TO REDUCE THE RISK OF ELECTRIC SHOCK, MAKE SURE THE 6510e IS EARTH GROUNDED BEFORE STARTING!

3.1.1 LINE VOLTAGE

The 6510e will operate from 85 to 264 VAC on a 50/60 Hz line voltage.

3.1.2 SELF-TEST

After turning the power on to the 6510e, the display panel will show all segments of the VFD (series of rectangles), indicating that the 6510e is downloading the program.

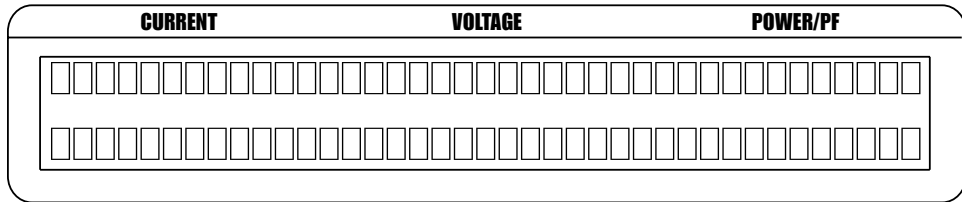

Figure 3-1 Program Download Display

When the program download is complete, the Title Display will appear.

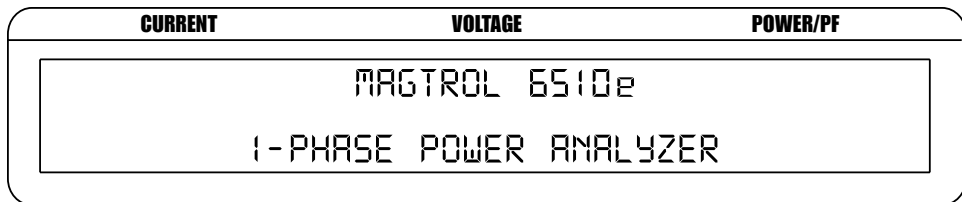

Figure 3-2 Title Display

Then an additional display will appear indicating the version of your Magtrol 6510e Power Analyzer.

CURRENT	VOLTAGE	POWER/PF
MAGTROL 6510e		
REV: 0.00		

Figure 3–3 Revision Display

3.1.3 MAIN MENU

When the 6510e is completely powered up and ready for use, the main menu will appear on the display. The main menu is defined by the last configuration that was used. This could include one of two different menus: phase or custom. The phase menu will appear as follows.

CURRENT	VOLTAGE	POWER/PF
0.000 AXX	0.000 VXX	0.000 XXX
000XX	000V	

Figure 3–4 Phase Main Menu

The custom menu can include up to 6 fields with selections dependent on the measurement mode.

CURRENT	VOLTAGE	POWER/PF
0.000 XX	0.000 XX	0.000 XX
0.000 XX	0.000 XX	0.000 XX

Figure 3–5 Custom Main Menu

3.2 PROTECTING YOUR 6510e

Before the 6510e is used for power measurement, guidelines regarding transient overloads, current overload, surge protection and circuit breakers must be followed.

3.2.1 TRANSIENT OVERLOADS

Connect an appropriate transient suppressor in parallel with all inductive loads. Consult the suppressor vendor's application literature for proper selection and sizing.



CAUTION: DAMAGE TO THE 6510e CAN RESULT FROM EXCESSIVE VOLTAGE TRANSIENTS GENERATED BY UNSUPPRESSED INDUCTIVE LOADS. THIS DAMAGE IS NOT WITHIN THE SCOPE OF THE NORMAL INSTRUMENT SERVICE AND IS NOT COVERED BY THE MAGTROL WARRANTY.

3.2.2 CURRENT OVERLOAD

There are no fuses in the 6510e measuring circuits. Therefore, excessive current passed through the amps terminals will cause excessive internal heating and possible unit damage.



CAUTION: THIS OVERLOAD ABUSE IS NOT COVERED BY THE MAGTROL WARRANTY.

Know your load conditions and double check all connections. If an overload should occur, immediately remove all power and locate and correct the problem before re-energizing your circuit. If a circuit breaker is installed, it must be installed on the load side of the 6510e (downstream). This will keep the low impedance of the input line connected to the 6510e for surge suppression. If the line side must also contain a breaker, it should be delayed in operation to open after the load side breaker has opened.

3.2.3 SURGE PROTECTION

Use Metal Oxide Varistors (MOV) or other equivalent transient suppressors connected between lines at the load (across the load). These suppressors are an absolute necessity when inductive loads are used. In three-phase systems, each load must have a suppressor.

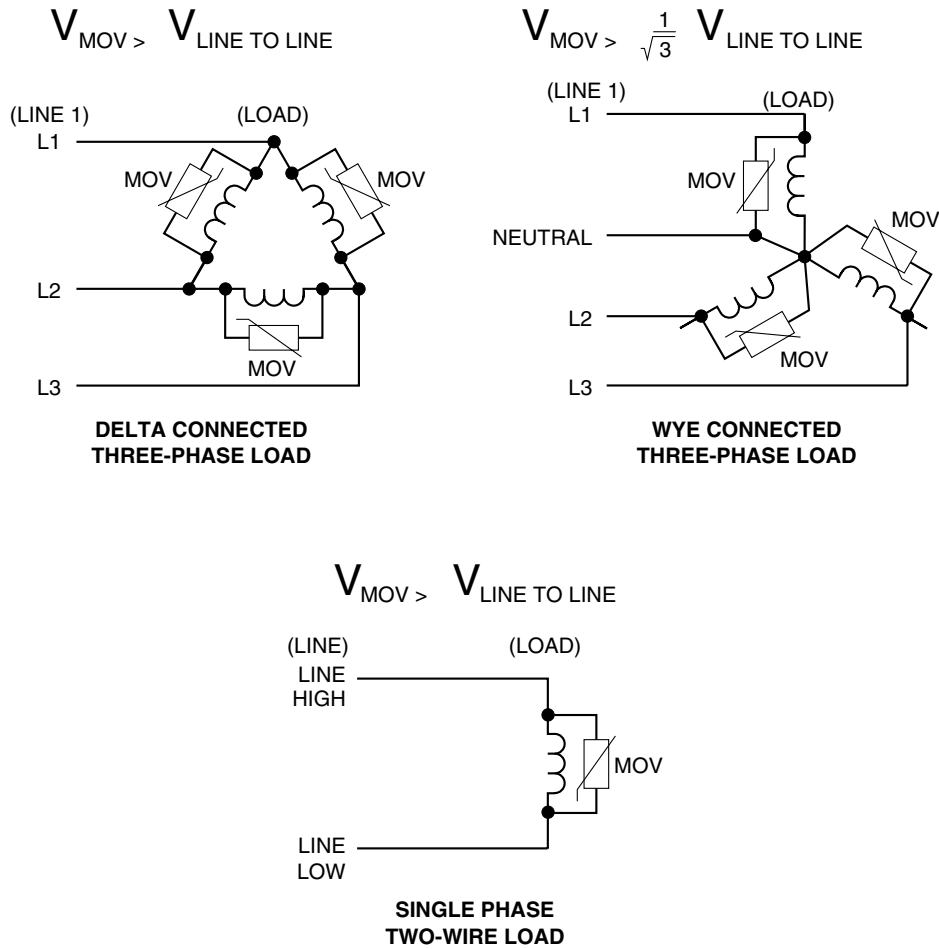

SETUP

Figure 3–6 Transient Voltage Suppression

3.2.4 CIRCUIT BREAKERS

The circuits described in *Section 3.3.1.1 – Hardware Connections* use the 6510e remote voltage sense by measuring the voltage at the load. This increases measurement accuracy by eliminating line voltage drop from the power measurement. For safety, an overload circuit breaker removes all load voltage during an over-current condition. The voltage sense lines are connected at the line side of the circuit breaker to help prevent inductive transients from entering the 6510e as the circuit breaker opens. Make sure that connections from the circuit breaker to the load are heavy conductors and short as possible.



CAUTION: IF A CIRCUIT BREAKER IS USED IN THE INPUT LINE TO THE 6510e, A CIRCUIT SHOULD BE USED THAT PREVENTS THE BREAKER FROM OPENING UNTIL AFTER THE LOAD SIDE BREAKER HAS OPENED. OTHERWISE, POTENTIALLY DAMAGING INDUCTIVE TRANSIENTS CAN BE APPLIED TO THE 6510e. DAMAGE CAUSED BY THESE TRANSIENTS ARE OUTSIDE THE SCOPE OF THE MAGTROL WARRANTY.

3.3 TESTING INSTRUMENTATION SETUP

Before the 6510e can be utilized, it must be configured and connected to the devices intended for power measurement.

3.3.1 WIRING MODE

The 6510e has the ability to support a 1-phase, 2-wire wiring connection.

3.3.1.1 Hardware Connection

- Most commonly used for single-phase AC and DC motor applications.
- The Power Factor is derived from the following equations:

$$\text{Active Power} = W$$

Active Power is the sum of the instantaneous volts multiplied by the instantaneous amps inputs.

$$\text{Apparent Power} = V_{\text{rms}} \times A_{\text{rms}} = \text{VA}$$

Apparent Power is the product of volts root mean square and amps root mean square.

$$\text{Power Factor} = W/\text{VA}$$

The following diagrams show the connections for a 1-Phase, 2-wire measurement.



Figure 3-7 Single-Phase, Two-Wire Wiring Schematic

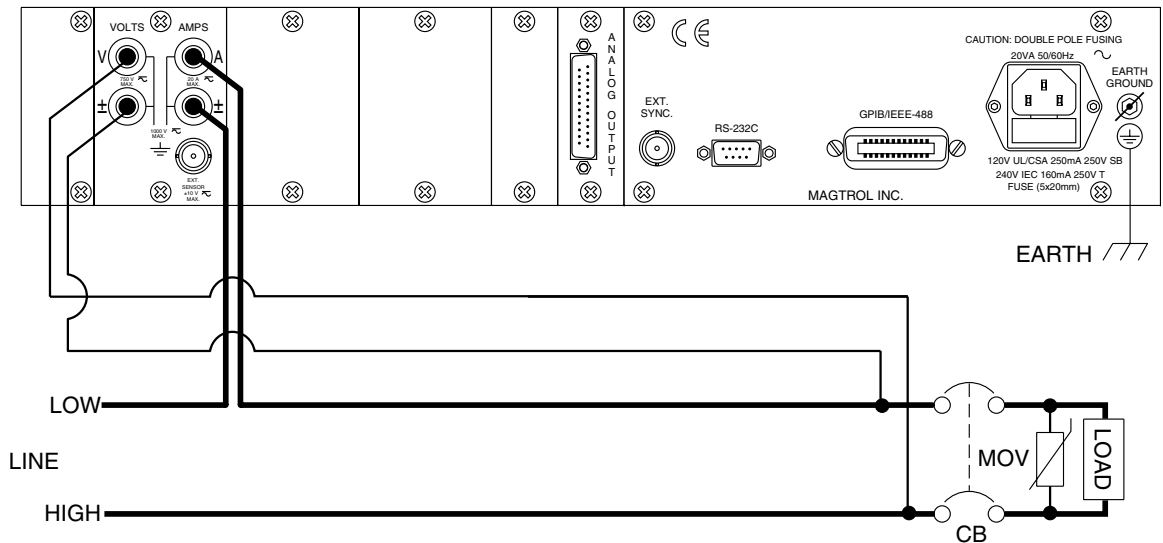

Figure 3-8 Single-Phase, Two-Wire Wiring Connection

SETUP

3.3.1.2 Software Configuration

The 6510e wiring mode default is set at 1-phase, 2-wire, therefore no software configuration is needed.

3.3.2 MEASUREMENT FILTER

During the RMS calculations, in the signal-processing path, there is a digital low-pass filter. The user can program the filter's cutoff frequency.

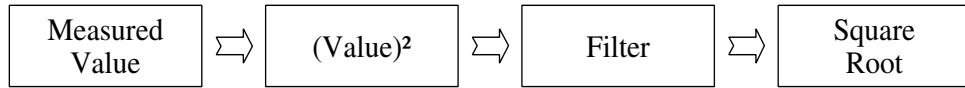

- Selections include 1 Hz, 2 Hz, 5 Hz, 10 Hz, 20 Hz, 50 Hz and 100 Hz .
- Correlation between filter setting and response is as follows:

Filter Setting	Response to Signal Change	Outcome
Low	Slow	Stable Reading
High	Fast	Unstable Reading

For more detailed information on theory, see *Chapter 4 – Operating Principles*.

3.3.2.1 Hardware Connection

Not applicable.

3.3.2.2 Software Configuration

To configure the 6510e measurement filter, complete the following steps utilizing the USER MENU located on the front panel of the unit.

1. Turn on the 6510e. See *Section 3.1 – Powering Up the 6510e*.
2. Press ENTER button. The display should appear as shown in *Figure 2–3 Device Setup Menu*.
3. Press ◀ and ▶ buttons until MEASUREMENT FILTER appears in the display.
4. Press ▲ and ▼ buttons until desired measurement filter is reached.
5. Press ENTER to exit Device Setup Menu.

3.3.3 EXTERNAL SENSOR

If currents continuously reach above 20 amps, an external sensor must be used.

3.3.3.1 Hardware Connection

In the wiring mode, the amp meter may be replaced. The following diagram illustrates the connection.

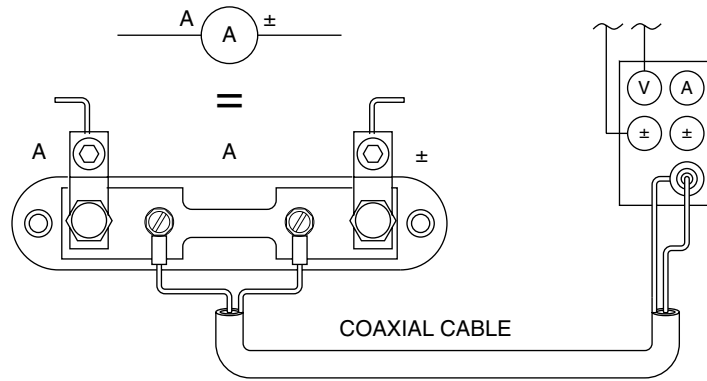

Figure 3-9 Sensor Substitution Wiring Schematic

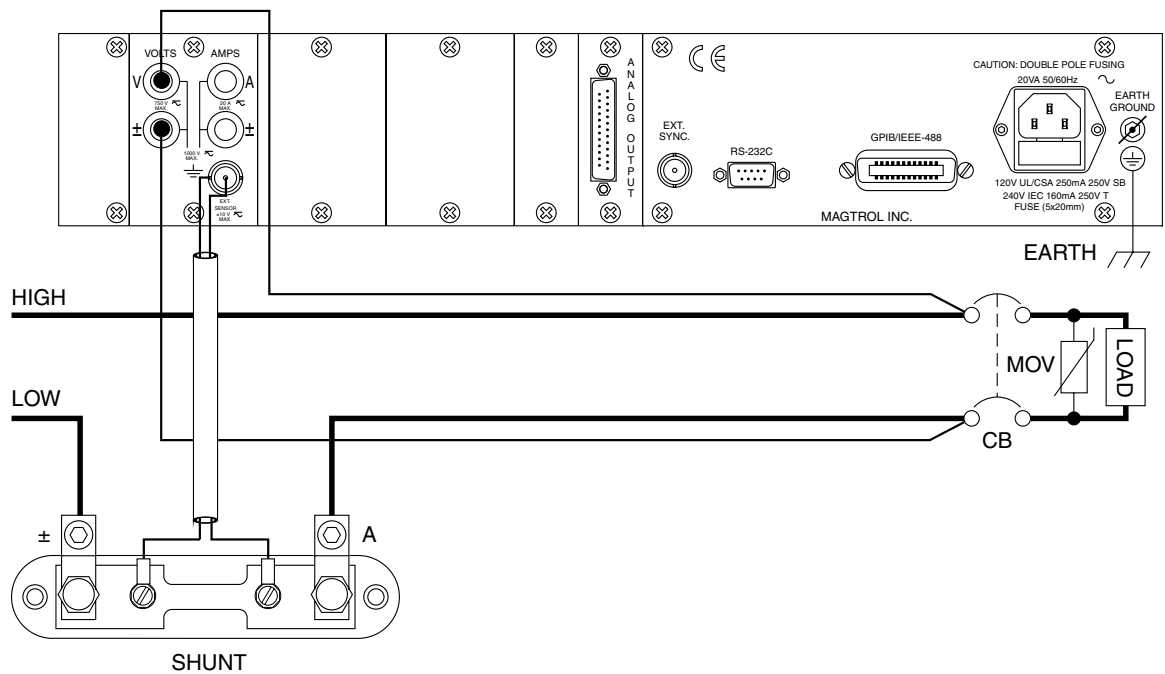

Figure 3-10 Sensor Substitution Wiring Connection

SETUP

3.3.3.2 Software Configuration

To configure the 6510e external sensor, complete the following steps utilizing the USER MENU located on the front panel of the unit.

1. Turn on the 6510e. See *Section 3.1 – Powering Up the 6510e*.
2. Press ENTER button. The display should appear as shown in *Figure 2–3 Device Setup Menu*.
3. Press ◀ and ▶ buttons until EXTERNAL SENSOR appears in the display.
4. Press ENTER button. The display will appear as follows.

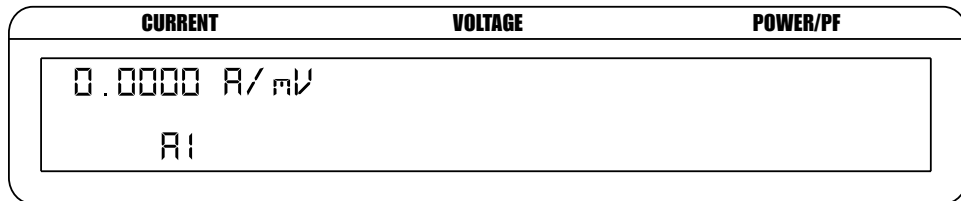

Figure 3–11 External Sensor Scale Factor Setup Menu

5. To set the scale factor, press the RMS button under A1 and use the ▲▼◀▶ buttons in the USER MENU to adjust the value.
6. Press ENTER to exit the Device Setup Menu.

3.3.4 AMP SCALING

The current measurement range can be extended by using a current transformer. Frequency response will be determined by the characteristics of the transformer used.

3.3.1 Hardware Connection

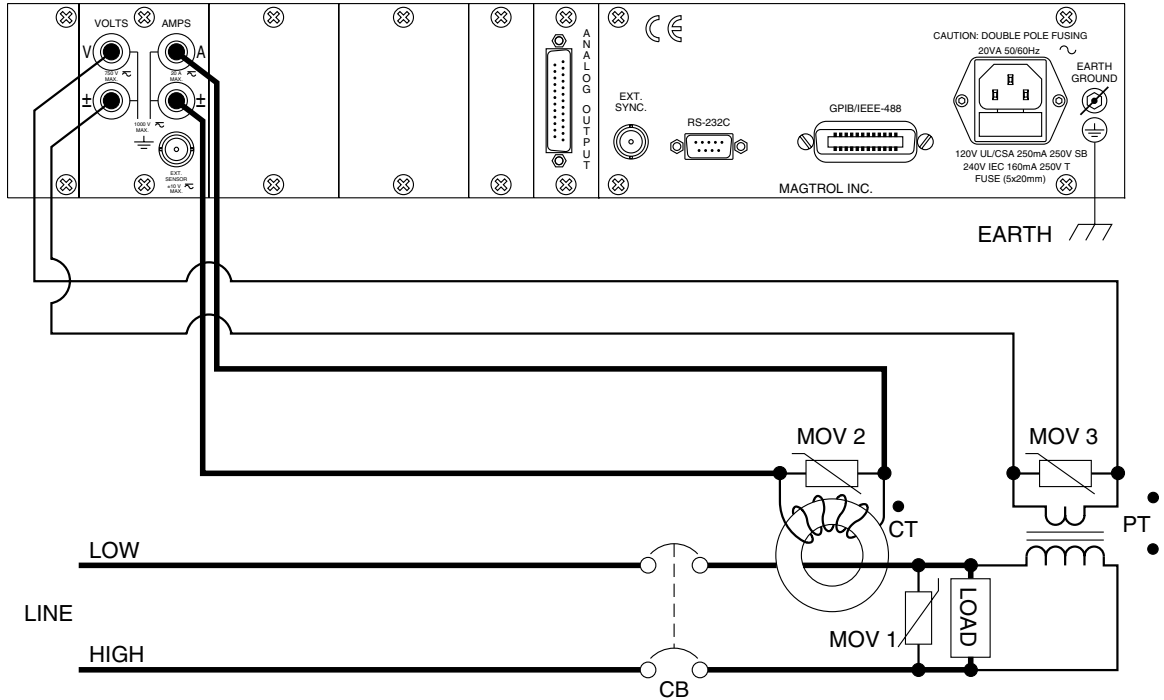

Figure 3–12 Current/Potential Transformer Connection

3.3.4.2 Software Configuration

To configure the 6510e amp scaling for a current transformer, complete the following steps utilizing the USER MENU located on the front panel of the unit.

1. Turn on the 6510e. See Section 3.1 – Powering Up the 6510e.
2. Press ENTER button. The display should appear as shown in Figure 2–3 Device Setup Menu.
3. Press ◀ and ▶ buttons until AMP SCALING appears in the display.
4. Press ENTER button. The display will appear as follows.

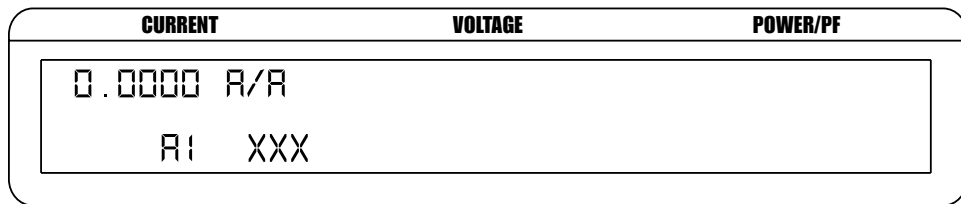

Figure 3–13 Amp Scaling Setup Menu

5. To set amp scaling, press the RMS button under A1 and use the ▲▼◀▶ buttons in the USER MENU to adjust the value.

SETUP

6. To turn scaling ON, press the PEAK-CF button under OFF until ON is reached.
7. Press ENTER to exit the Device Setup Menu.



Note: When amps scaling has been activated, “*” will appear in the main menu next to the amps range as shown in the following figure.

CURRENT	VOLTAGE	POWER/PF
0.000 AXX	0.000 VXX	0.000 XXX
000XX*	000V*	SHIFT

* SCALING ACTIVATED

Figure 3–14 Amp/Volt Scaling Activated

3.3.5 VOLTS SCALING

The voltage measurement range can be extended by using a potential transformer. Frequency response will be determined by the characteristics of the transformer used.

3.3.5.1 Hardware Connection

See *Figure 3–12 Current/Potential Transformer Connection*.

3.3.5.2 Software Configuration

To configure the 6510e volt scaling for a potential transformer, complete the following steps utilizing the USER MENU located on the front panel of the unit.

1. Turn on the 6510e. See *Section 3.1 – Powering Up the 6510e*.
2. Press ENTER button. The display should appear as shown in *Figure 2–3 Device Setup Menu*.
3. Press ◀ and ▶ buttons until VOLT SCALING appears in the display.
4. Press ENTER button. The display will appear as follows.

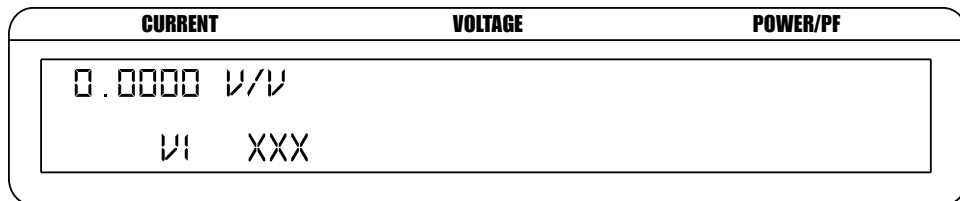

Figure 3–15 Volt Scaling Setup Menu

5. To set volt scaling, press the RMS button under V1 and use the ▲▼◀▶ buttons in the USER MENU to adjust the value.
6. To turn scaling ON, press the PEAK-CF button under OFF until ON is reached.
7. Press ENTER to exit the Device Setup Menu.



Note: When volts scaling has been activated, “*” will appear in the main menu next to the volts range as shown in *Figure 3–14 Amp/Volt Scaling Activated*.

3.3.6 PHASE SETUP

Once the wiring mode, measurement filter, external sensor, amp scaling and volt scaling have been connected and configured, the unit is ready to be configured for phase setup.

1. Select current measurement mode (DC, RMS, peak, crest factor or peak hold).
 - a. To select DC press SHIFT and release, then press DC button located in CURRENT RANGE section of front panel.
 - b. To select RMS press SHIFT and release, then press RMS button located in CURRENT RANGE section of front panel.
 - c. To select peak, crest factor or peak hold, press SHIFT and release, then press PEAK-CF button located in CURRENT RANGE section of front panel. Keep pressing SHIFT and PEAK-CF buttons until desired selection appears in display. For more information on peak, crest factor and peak hold, see *Section 4.3 – Measurement Modes*.
2. Select current range by using the ▲ and ▼ buttons located in CURRENT RANGE section of front panel. Selections include 50 mV, 250 mV, 0.5 V and 1 V when using an external sensor and 1 A, 5 A, 10 A and 20 A when using amps input.
3. Select voltage measurement mode (DC, RMS, peak, crest factor or peak hold).
 - a. To select DC press SHIFT and release, then press DC button located in VOLTAGE RANGE section of front panel.
 - b. To select RMS press SHIFT and release, then press RMS button located in VOLTAGE RANGE section of front panel.
 - c. To select peak, crest factor or peak hold, press SHIFT and release, then press PEAK-CF button located in VOLTAGE RANGE section of front panel. Keep pressing SHIFT and PEAK-CF buttons until desired selection appears in display. For more information on peak, crest factor and peak hold, see *Section 4.3 – Measurement Modes*.
4. Select voltage range by using the ▲ and ▼ buttons located in VOLTAGE RANGE section of front panel. Selections include 30 V, 150 V, 300 V and 600 V.
5. Press W-VA-PF button until desired selection is reached. Selections include W[↑], W, VA and PF.
6. Once the phase has been configured, cycle-by-cycle or continuous must be chosen. See *Section 4.4 – Measurement Methods*.
 - a.1. For cycle-by-cycle mode, press CYC-CONT button until display shows source reading in lower right corner similar to the following figure.

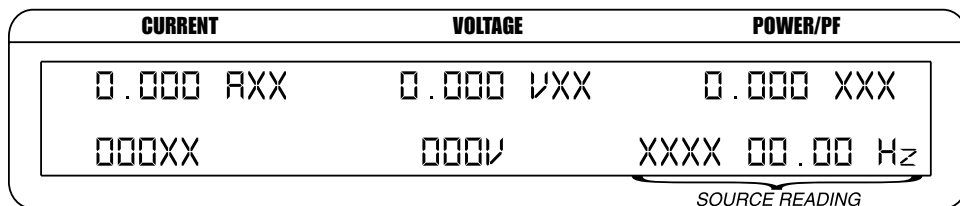

Figure 3-16 Cycle-by-Cycle Mode

- a.2. A source now needs to be selected. Press SHIFT button and release, then press SOURCE button. Keep repeating until desired source selection is reached. Selections include VOLT, AMP, EXT and LINE.
- b. For continuous mode, press CYC-CONT until display does not show any readings in the lower right corner.

3.3.7 SPECIAL FUNCTIONS

3.3.7.1 Hold

- Freezes display values.
- To set, press and release HOLD button. The display will appear as follows, indicating that the hold function is enabled.

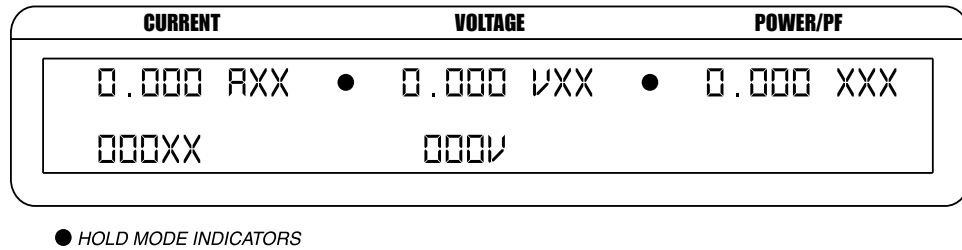

Figure 3-17 Hold Mode

- To disable, press and release HOLD button.

3.3.7.2 Average

- Mode in which the power analyzer displays the running average of amps, volts and watts.
- Used to stabilize mildly fluctuating readings or to determine watt-hours when used in conjunction with a timer.
- To set, press SHIFT button and release, then press AVG. The display will appear as follows, indicating that the Average Function is enabled.

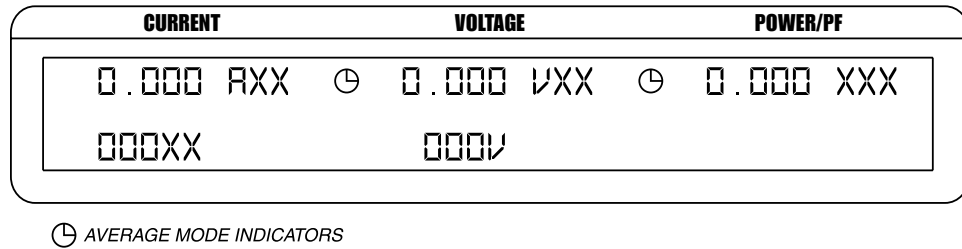

Figure 3-18 Average Mode

- To disable, press SHIFT button and release, then press AVG.

3.3.7.3 Peak Hold

- Clears peak hold/inrush reading.
- To enable, press SHIFT button and release, then press PEAK HOLD. The display will flash the following, then return to the main menu.

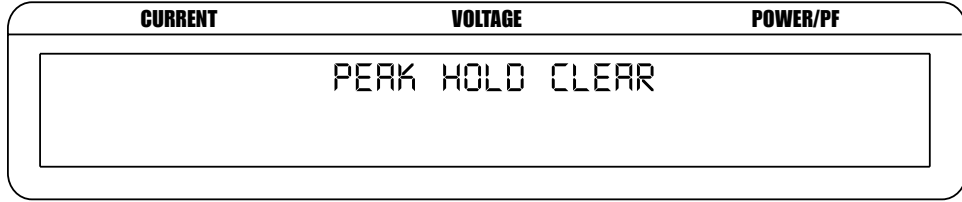

Figure 3–19 Peak Hold Clear Display

3.3.7.4 Custom Display

- The display can be configured to present data in any format.
- To set, press SHIFT button and release, then press DISPLAY. The display will appear as follows.

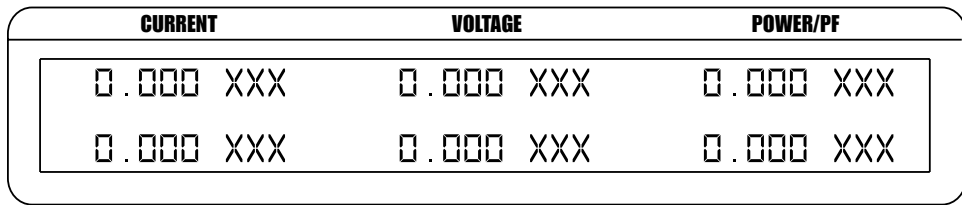

Figure 3–20 Custom Display

- There are 6 fields in the display that can be customized with information based on the phase setup. To set, from the USER MENU control buttons, toggle from field to field by using the ◀ and ▶ buttons and make selections using the ▲ and ▼ buttons. If there is not a preferred value for a specific field, press ENTER when the field is selected and it will be deleted from the display.

SETUP

4. Operating Principles

4.1 ANALOG PROCESSING

4.1.1 VOLTS

The volts signal is brought in through a precision voltage divider of 2 M and 2.4 k resistors. The gain is 0.0012. This signal is buffered (GAIN = 1) and passed into a programmable gain section. The gains for the voltage ranges are given below.

Range	Resistors	Gain (Amplifier)
30 V	12 k / 620	-19.350
150 V	2.4 k / 620	-3.871
300 V	1.2 k / 620	-1.936
600 V	620 / 620	-1.000

The signal is then presented to an AD7722AS 16-bit analog to digital converter. The part accepts an input signal of ± 1.25 volts centered on a 2.5 VDC volt bias. The chart below shows system input at 10% and 100% of range.

Range	Volts In (VDC)	Gain (total)	Volts at A/D Input	Bits
30 V	3	-0.023220	-0.0697	1826
	30	-0.023220	-0.6966	18261
150 V	15	-0.004645	-0.0697	1826
	150	-0.004645	-0.6968	18265
300 V	30	-0.002323	-0.0697	1827
	300	-0.002323	-0.6969	18269
600 V	60	-0.001200	-0.0720	1887
	600	-0.001200	-0.7200	18874

Converter Resolution: $2.5 / 2^{16} = 2.5 / 65536 = 0.00003814697$

4.1.2 AMPS

The amps signal is brought in through a precision shunt of 0.012 ohms. This signal is amplified by 2 and passed into a programmable gain section. The gains for the voltage ranges are given below.

Range	Resistors	Gain (Amplifier)
1 A	12 k / 620	-19.350
5 A	2.4 k / 620	-3.871
10 A	1.2 k / 620	-1.936
20 A	620 / 620	-1.000

The signal is then presented to an AD7722AS 16-bit analog to digital converter. The part accepts an input signal of ± 1.25 volts centered on a 2.5 VDC volt bias. The chart below shows system input at 10% and 100% of range.

Range	Amps In (ADC)	Shunt Volts	First Stage Amp	Gain	Volts at A/D Input	Bits
1 A	0.1	0.0012	-0.0024	-19.35000	0.0464	1217
	1.0	0.0120	-0.0240	-19.35000	0.4644	12174
5 A	0.5	0.0060	-0.0120	-3.87100	0.0465	1218
	5.0	0.0600	-0.1200	-3.87100	0.4645	12177
10 A	1.0	0.0120	-0.0240	-1.93600	0.0465	1218
	10.0	0.1200	-0.2400	-1.93600	0.4646	12180
20 A	2.0	0.0240	-0.0480	-1.00000	0.0480	1258
	20.0	0.2400	-0.4800	-1.00000	0.4800	12583

Converter Resolution: $2.5 / 2^{16} = 2.5 / 65536 = 0.00003814697$
 Shunt resistance = 0.012

4.1.3 EXTERNAL SHUNT

The external shunt signal is brought in through a precision voltage divider of 9.1 k and 9.1 k resistors. The gain is 0.50. This signal is buffered and passed into a programmable gain section. The gains for the voltage ranges are given below.

Range	Resistors	Gain (Amplifier)
50 mV	12 k / 620	-19.350
250 mV	2.4 k / 620	-3.871
500 mV	1.2 k / 620	-1.936
1000 mV	620 / 620	-1.000

The signal is then presented to an AD7722AS 16-bit analog to digital converter. The part accepts an input signal of +/- 1.25 volts centered on a 2.5 VDC volt bias. The chart below shows system input at 10% and 100% of range.

Range	Volts In (VDC)	Gain (total)	Volts at A/D Input	Bits
50 mV	0.005	-9.67500	-0.0484	1268
	0.050	-9.67500	-0.4838	12681
250 mV	0.025	-1.93550	-0.0484	1268
	0.250	-1.93550	-0.4839	12684
500 mV	0.050	-0.96800	-0.0484	1269
	0.500	-0.96800	-0.4840	12688
1000 mV	0.100	-0.50000	-0.0500	1311
	1.000	-0.50000	-0.5000	13107

Converter Resolution: $2.5 / 2^{16} = 2.5 / 65536 = 0.00003814697$

4.2 DIGITAL PROCESSING

Starting at the AD7722AS analog to digital converter, the input clock to the device is 14.31818 MHz. This clock frequency gives a sample rate or data output rate of $14318180 / 64 = 223721.5625$ samples per second.

The DSP processor uses fractional data representation for all Data ALU operations. Using long words (48-bit) the most negative number that can be represented is -1 (\$800000000000). The most positive number that can be represented is $1 - 2^{-47}$ (\$7FFFFFFFFFFFF).

Example:

\$123456 (Hex integer)

0001 0010 0011 0100 0101 0110 (Binary)

0.142222166 (Fractional)

4.2.1 AC DETAILS

4.2.1.1 Interrupt Driven

The power analyzer will automatically update its data every 4.469 microseconds by completing the following sequence of events:

- The volts input is read and checked for an over range condition. The offset is then added to the reading and the reading is negated and saved.
- The amps input is read and checked for an over range condition. The offset is then added to the reading and the reading is negated and saved.
- The volt reading is checked to see if it is the peak and if so is stored.
- The amp reading is checked to see if it is the peak and if so is stored.
- The volt reading is squared and the squared reading is summed.
- The volt and amp reading is multiplied and the multiplied value is summed.
- The amp reading is squared and summed.



Note: After 256 readings are summed, the sums are transferred to a 56-bit V^2 register, a 56-bit VI register, and a 56-bit I^2 register. A sample ready flag is set.

4.2.1.2 Main Program

The main program reads that a sample is ready.

Divide the V^2 register by 256.
Store V^2 in a 24-bit register. (See *Section 4.2.3 – Round-Off Error*).
The result is appended to a 32 word circular buffer.
Add buffer contents and divide by 32.
The result is appended to a 2cd 32 word circular buffer.

Divide the I^2 register by 256.
Store I^2 in a 24-bit register.
The result is appended to a 32 word circular buffer.
Add buffer contents and divide by 32.
The result is appended to a 2cd 32 word circular buffer.

Divide VI register by 256.
Store VI in a 24-bit register.
The result is appended to a 32 word circular buffer.
Add buffer contents and divide by 32.
The result is appended to a 2cd 32 word circular buffer.

Add 2cd V^2 buffer contents and divide by 32. Save this value.
Add 2cd I^2 buffer contents and divide by 32. Save this value.
Add 2cd VI buffer contents and divide by 32. Save this value.

Each sample is now 256 X (32 + 32) (16384) a/d samples. At 223721.5625 samples per second that is 73.23388 ms for a new input to fully average.

The VI sample is applied to an RC filter algorithm.
The output of the filter is multiplied by a gain value.
This value is stored for output.

The V^2 sample is applied to an RC filter algorithm.
The square root of the output is taken.
The result is multiplied by a gain value.
This value is stored for output.

The I^2 sample is applied to an RC filter algorithm.
The square root of the output is taken.
The result is multiplied by a gain value.
This value is stored for output.

These values are updated at 873.912 readings per second.

Every 8th time through the loop or at a rate of 109.239 the V and I peak values are stored for output and the data ready flag is set.

4.2.2 DC DETAILS

4.2.2.1 Interrupt Driven

The power analyzer will automatically update its data every 4.469 microseconds by completing the following sequence of events:

- The volts input is read and checked for an over range condition. The offset is then added to the reading and the reading is negated and saved.
- The amps input is read and checked for an over range condition. The offset is then added to the reading and the reading is negated and saved.
- The volt reading is checked to see if it is the peak and if so, is stored.
- The amp reading is checked to see if it is the peak and if so, is stored.
- The volt reading is summed.
- The amp reading is summed.
- The volt and amp reading is multiplied.
- The multiplied value is summed.



Note: After 256 readings are summed the sums are transferred to a 56-bit V register, a 56-bit I register, and a 56-bit VI register. A sample ready flag is set.

4.2.2.2 Main Program

The main program reads that a sample is ready.

Divide the V register by 256.
Store V in a 24-bit register.
The result is appended to a 32 word circular buffer.
Add buffer contents and divide by 32.
The result is appended to a 2cd 32 word circular buffer.

Divide the I register by 256.
Store I in a 24-bit register.
The result is appended to a 32 word circular buffer.
Add buffer contents and divide by 32.
The result is appended to a 2cd 32 word circular buffer.

Divide the VI register by 256.
Store VI in a 24-bit register.
The result is appended to a 32 word circular buffer.
Add buffer contents and divide by 32.
The result is appended to a 2cd 32 word circular buffer.

Add 2cd V2 buffer contents and divide by 32. Save this value.
Add 2cd I2 buffer contents and divide by 32. Save this value.
Add 2cd VI buffer contents and divide by 32. Save this value.

Each sample is now $256 \times (32 + 32) = 16384$ a/d samples. At 223721.5625 samples per second that is 73.23388 ms for a new input too fully average.

The VI sample is applied to an RC filter algorithm.
The output of the filter is multiplied by a gain value.
This value is stored for output.

The V sample is applied to an RC filter algorithm.
The output of the filter is multiplied by a gain value.
This value is stored for output.

The I sample is applied to an RC filter algorithm.
The output of the filter is multiplied by a gain value.
This value is stored for output.

These values are updated at 873.912 readings per second.

Every 8th time through the loop or at a rate of 109.239 the V and I peak values are stored for output and the data ready flag is set.

4.2.3 ROUND-OFF ERROR

The interrupt routine adds 256 56-bit squared readings. This reading is then divided by 256 and put into a 24-bit register. Some error occurs during the move to the 24-bit register. The result of the 16-bit A/D conversion is put into the high 16 bits of a 24-bit register.

Example 1: A/D reading = 000B
 56-bit register = 00 000B00 000000 (0.0003357)
 Square of 56-bit = 00 000000 F20000 (0.00000012269)
 Store to 24-bit = 000000 (0.0000000)

Example 2: A/D reading = 000C
 56-bit register = 00 000C00 000000 (0.0003662)
 Square of 56-bit = 00 000001 200000 (0.00000013411)
 Store to 24-bit = 000001

4.3 MEASUREMENT MODES

4.3.1 PEAK

The peak value is defined as the highest value that occurs in the cycle of a repetitive waveform.

The graph below shows one cycle of a repetitive waveform. The peak value is shown. The absolute value of the reading is used to determine the peak value.

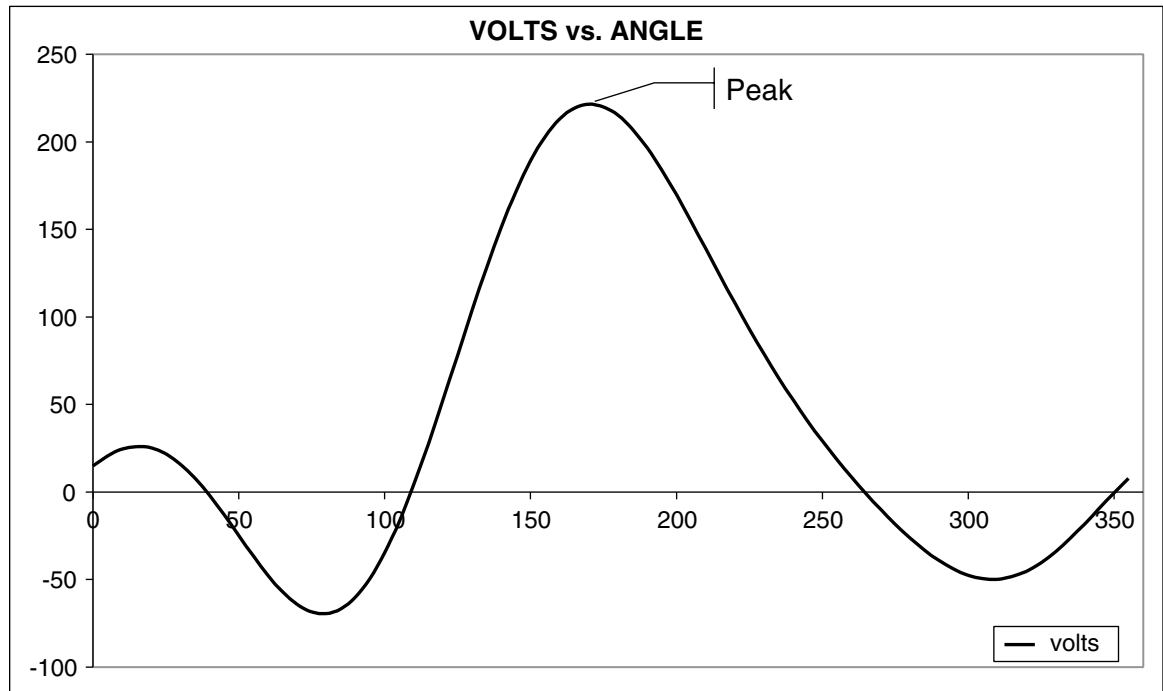

Figure 4-1 Peak Example

THEORY

4.3.2 PEAK HOLD / INRUSH CURRENT

Peak hold/inrush current allows the 6510e to store the highest value read in a designated period of time, the designated period of time being the time span since the last peak hold clear occurred. Values include amps, watts and volts in any preferred combination. See *Section 3.3.7.3 – Peak Hold*.

The graph below shows the current draw from a 1/3 horsepower motor during initial startup. At startup the current inrush peaks at about 14 amps then settles to 4.25 amps. When the unit is in peak hold/ inrush mode of operation, the front panel current reading displays 14.033 amps. The current reading indicates the peak inrush current, which is determined by the RMS value.

The operation of the volts and watts peak hold follows the same operation as explained for the current above.

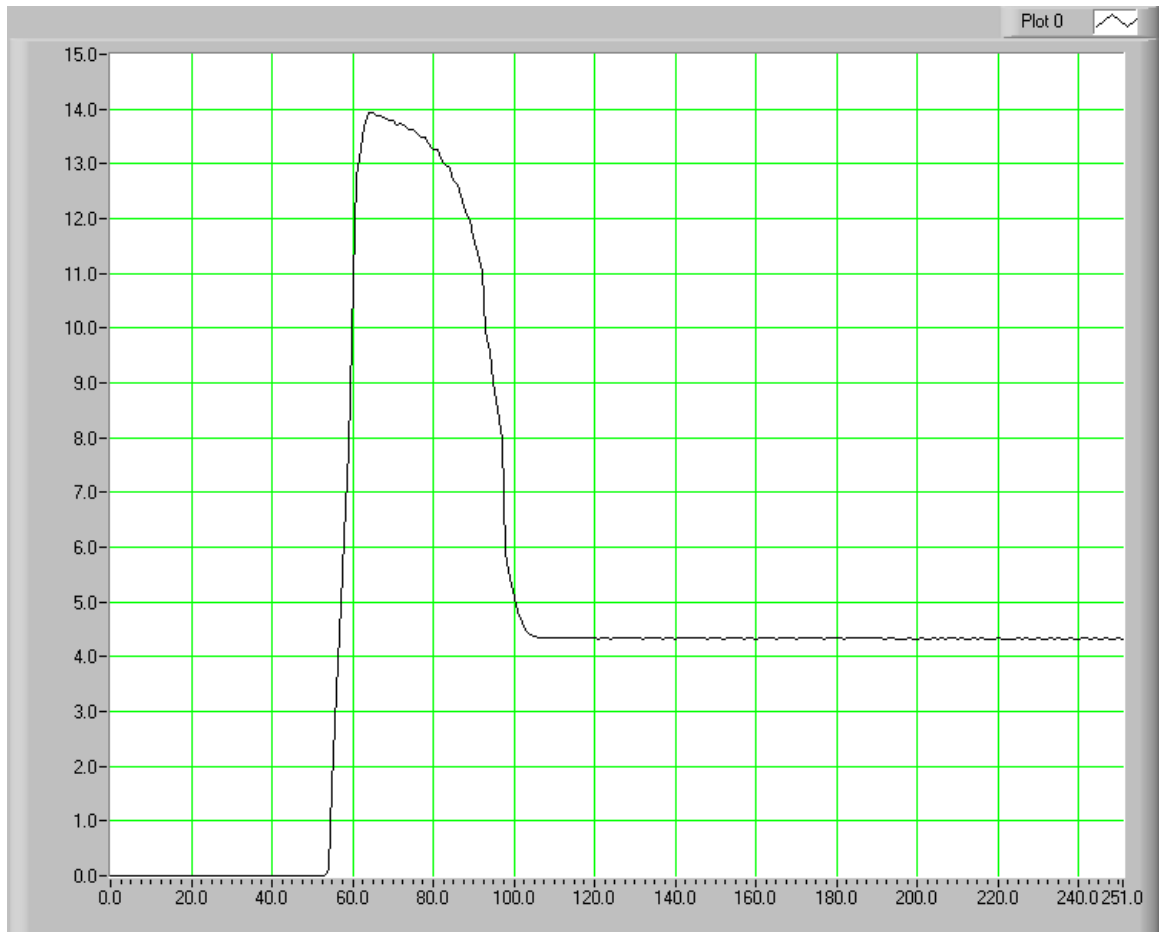

Figure 4–2 Peak Hold/Inrush Current Example

4.3.3 DC

See *Section 4.2.2 – DC Details*.

4.3.4 RMS

See Section 4.2.1 – AC Details

4.3.5 CREST FACTOR

The crest factor measurement is determined by dividing the peak measurement by the RMS measurement. See the following graph for reference.

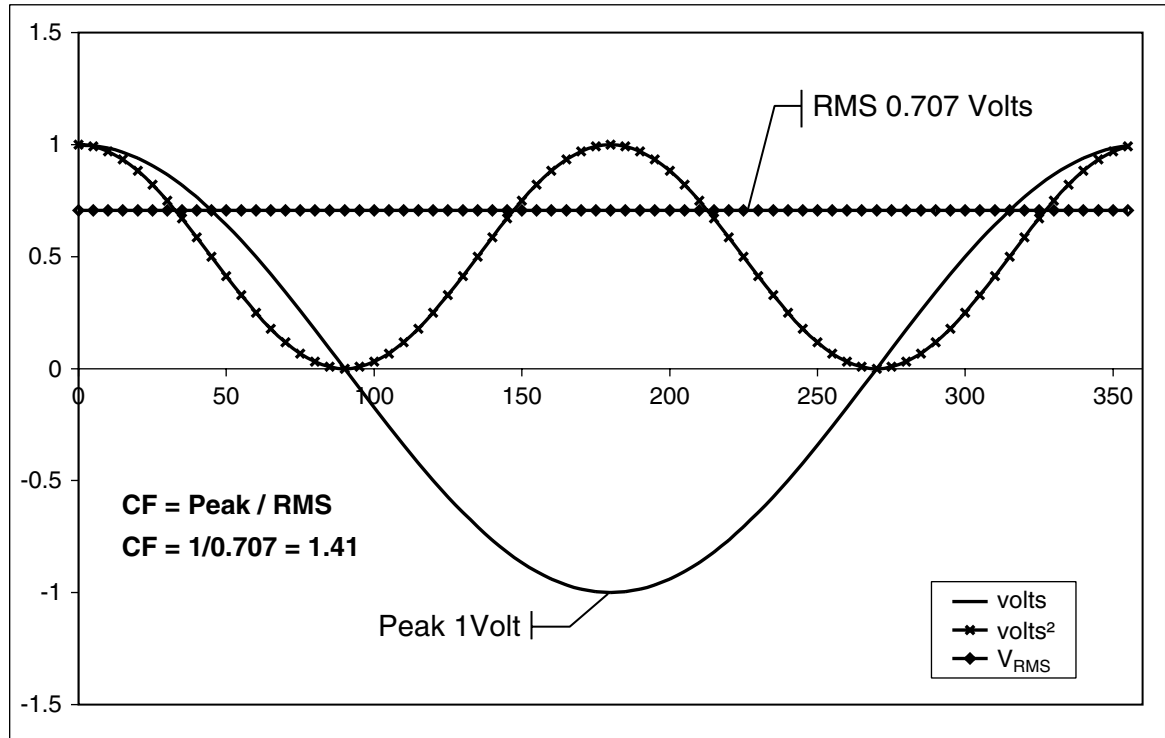

Figure 4-3 Crest Factor Example

4.4 MEASUREMENT METHODS

4.4.1 CYCLE-BY-CYCLE MODE

In the cycle-by-cycle mode the power analyzer looks at each complete cycle of the incoming waveform. The measurements are valid from 20 Hz to 500 Hz. The power analyzer may be synchronized from any of the phase volts or amps inputs, the line voltage or the back panel external sync input. If using volts or amps for synchronization, the input must be greater than 10% of the range setting.

4.4.2 CONTINUOUS MODE

In the continuous mode the measurement values are determined from continuously processed and filtered volts and amps input values. The measurements are valid from DC to 100 kHz and the output data rate from the process is about 109.24 samples per second. The power analyzer does not have to be synchronized to the measured waveform and the user may select the filter to be used in the mean process of the RMS value.

5. Computer Controlled Operation

Using the 6510e with a personal computer (PC) enables the unit to perform at its full capacity.

5.1 ABOUT THE GPIB INTERFACE

Magtrol prefers the GPIB (General Purpose Interface Bus)/IEEE-488 Standard for computer-to-instrument interfacing because:

- The GPIB parallel interface is faster than serial interfaces.
- The GPIB enables testers to access up to 15 instruments on one port. Because typical motor testing requires that at least five separate parameters be synchronized, a system of easy, fast access to more than one instrument is essential.
- The GPIB has rigid data formatting and hardware standards. These standards help to ensure that all functions will work properly when the hardware and software are installed.



Note: The GPIB interface is not standard on most personal computers. An interface card and driver software must be installed. An IEEE-488 cable must also be installed between the computer and the 6510e. Magtrol recommends National Instruments Corporation hardware and software.

5.1.1 INSTALLING THE GPIB/IEEE-488 CONNECTOR CABLE



CAUTION: MAKE SURE BOTH THE COMPUTER AND 6510e ARE TURNED OFF BEFORE INSTALLING THE GPIB CONNECTOR CABLE.

1. Connect one end of a high-quality, double-shielded cable to the 6510e GPIB connector.
2. Connect the other end to the GPIB interface in your PC.

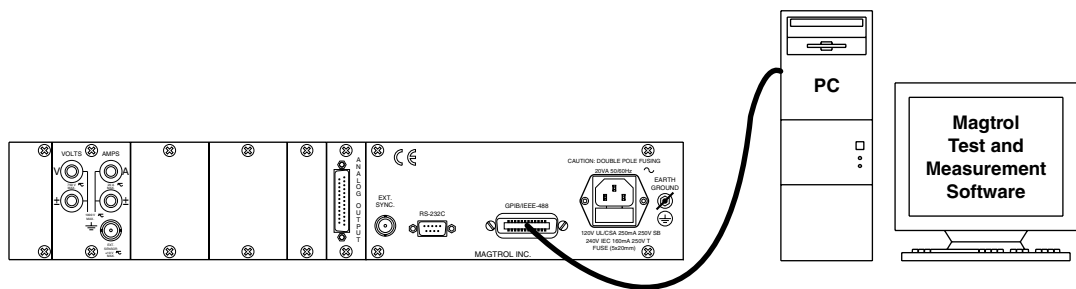

Figure 5-1 GPIB Installation

5.1.2 CHANGING THE GPIB PRIMARY ADDRESS

Each instrument serviced by the GPIB has its own primary address code, which enables the computer to obtain readings from the instrument. The factory default of the GPIB address on the 6510e is 14.

Some PC interfaces can access from one to fifteen 4-bit primary addresses. Other interfaces can access as many as thirty-one 5-bit primary addresses. The 6510e uses the 4-bit format. For setup, complete the following instructions utilizing the USER MENU control buttons.

1. Press ENTER.
2. Use the ◀ and ▶ buttons until I/O is reached.
3. Press ENTER.
4. Use the ◀ and ▶ buttons until GPIB ADDRESS is reached. The display should appear as follows:

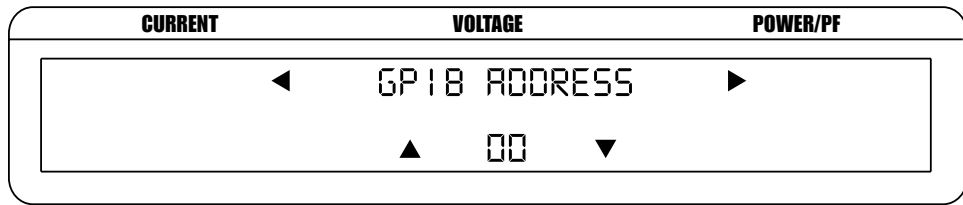

Figure 5-2 GPIB Address Setup Menu

5. Use the ▲ and ▼ buttons until desired primary address is reached (range 0-15).
6. Press ENTER to return to main menu.

5.2 ABOUT THE RS-232 INTERFACE

The 6510e is equipped with an RS-232 (serial) interface that communicates with the host computer through a DB-9 interface connector. The connector pin-out consists of 2-RX, 3-TX and 5-GND.

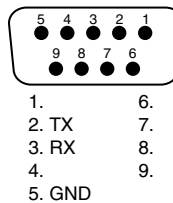

Figure 5-3 RS-232 Interface

5.2.1 CONNECTION

The RS-232 requires null modem wiring. To install use a null modem connector cable, which can be purchased from your local electronics store.

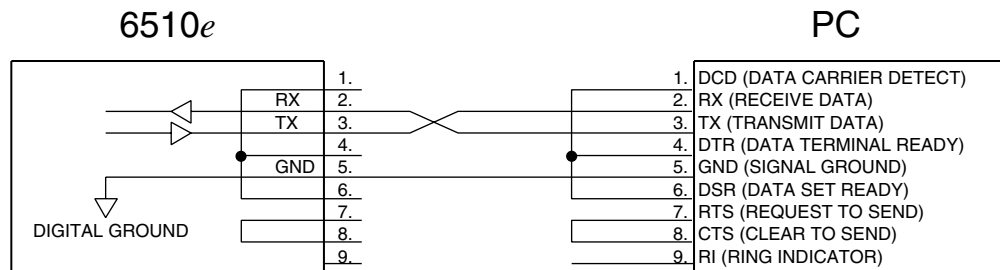

Figure 5-4 Cable Connection Using Null Modem

OPERATION

5.2.2 COMMUNICATION PARAMETERS

- No parity
- 8 data bits
- 1 stop bit

5.2.3 BAUD RATE

There are several different baud rates to choose from including 300, 600, 1200, 2400, 4800, 9600, 19200 and 115200. To set up the desired baud rate, complete the following instructions utilizing the USER MENU control buttons.

1. Press ENTER.
2. Use the ◀ and ▶ buttons until I/O is reached.
3. Press ENTER.
4. Use the ◀ and ▶ buttons until RS-232 BAUDRATE is reached. The display should appear as follows:

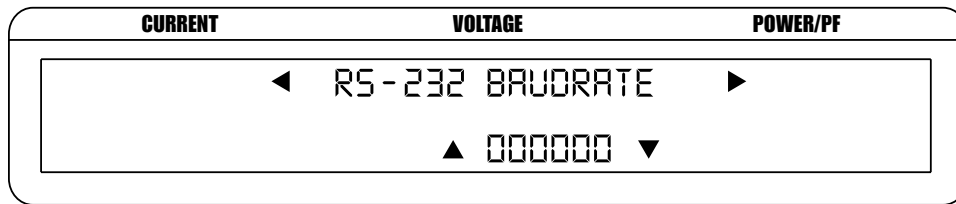

Figure 5–5 RS-232 Baud Rate Setup Menu

5. Use the ▲ and ▼ buttons until desired baud rate is reached.
6. Press ENTER to return to main menu.

5.3 CHECKING THE 6510e-TO-PC CONNECTION



Note: Make sure that the 6510e and its host computer are communicating before acquiring data.

1. Make sure the primary GPIB address is set correctly for the 6510e.
2. Set the input variable to 15 characters (13 variable characters and the two required data termination characters CR and LF. See Section 5.5 – Programming.)
3. Issue output data command “*IDN?” and read 15 characters according to the instructions for your GPIB interface or serial.

Desired Results

- output_string = “6510e R x.xx”<delimiter>



Note: If the desired results did not occur, please see Chapter 8 – Troubleshooting.

OPERATION

5.4.2 OE EXAMPLE

Total = 43 characters

Output String: (1-42) = measurement value float E notation (ANSI)

Data Position: Ax, Vx, Wx (where x = requested phase)

5.4.2.1 Good Response

```
\s\s1.83352E-01,\s\s1.19342E+02,\s\s1.29812E+01\r\n
```

5.4.2.2 Over-Range Condition

```
\s\s1.84250E-01,^\s4.95238E+01,^\s4.26064E+00\r\n
```

5.4.3 OA/OV/OW/OF EXAMPLE

Total = 15 characters

Output String: (1-14) = measurement value float E notation (ANSI)

5.4.3.1 Good Response

```
\s\s1.19494E+02\r\n
```

5.4.3.2 Over-Range Condition

```
^\s4.94796E+01\r\n
```

5.5 PROGRAMMING

Note: Check the manual provided with your software for full instructions.

5.5.1 DATA TERMINATION CHARACTERS

Use the following information to answer the formatting questions asked when installing your GPIB software. All GPIB data acquisition systems require the use of data termination characters. The 6510e uses the GPIB standard termination characters Carriage Return (CR) and Line Feed (LF). Provide them in that order.

5.5.12 Codes for CR-LF

	BASIC	HEX	DEC
CR =	CHR\$(13)	OD	13
LF =	CHR\$(10)	OA	10

5.6 6510e COMMUNICATION COMMANDS

IEEE-488	Address:	0-15
	Terminator:	carriage return followed by a line feed
RS-232	Baud Rate:	300, 600, 1200, 2400, 4800, 9600, 19.2 k, 115.2 k
	Terminator:	carriage return followed by a line feed

When entering a command code:

1. Type all characters in uppercase ASCII format.
2. End all commands with a carriage return followed by a line feed.
3. Do not string multiple commands together in one line.



Note: If a command is not recognized, the I/O ERROR message will appear in the Status Display accompanied by a beep.

5.6.1 CONFIGURATION COMMANDS

Command Code	Function	Explanation
*IDN? <terminator>	Identification query.	Returns model number and code revision.
AA1,m2<terminator>	Sets auto or manual range mode for the amps ranges.	"m2" indicates whether range mode is auto or manual. Values for <i>m2</i> are: 0 = manual range 1 = auto range
AV1,m2<terminator>	Sets auto or manual range mode for the voltage ranges.	"m2" indicates whether range mode is auto or manual. Values for <i>m2</i> are: 0 = manual range 1 = auto range
FSm<terminator>	Sets the frequency source for cycle-by-cycle mode.	"m" indicates the input to be used as the fundamental source. Values for <i>m</i> are: 0 = V1 1 = A1 6 = EXT (external input) 7 = LINE (50/60 Hz)
IS	Starts average mode.	---
IC	Clears average mode.	---
MA1,m2<terminator>	Sets the RMS or DC measurement mode of amps.	"m2" indicates measurement mode. Values for <i>m2</i> are: 0 = RMS (AC + DC) 1 = DC
MV1,m2<terminator>	Sets the RMS or DC measurement mode of voltage.	"m2" indicates measurement mode. Values for <i>m2</i> are: 0 = RMS (AC + DC) 1 = DC
MCm<terminator>	Sets the continuous or cyclic measurement mode filter.	"m" indicates whether the measurement mode is continuous or cyclic. Values for <i>m</i> are: 0 = continuous 1 = cycle-by-cycle

Command Code	Function	Explanation
MFm<terminator>	Sets the AC and DC measurement mode filter.	"m" indicates the measurement filter low-pass frequency (response time). Values for <i>m</i> are: 0 = 1 Hz 1 = 2 Hz 2 = 5 Hz 3 = 10 Hz 4 = 20 Hz 5 = 40 Hz 6 = 100 Hz
PC<terminator>	Clears all peak hold values (volt, amp and watt).	---
RA1,m2<terminator>	Sets current range and input source.	"m2" indicates current range. Values for <i>m2</i> are: 0 = 20 A 1 = 10 A 2 = 5 A 3 = 1 A 4 = 1 V external sensor input range 5 = 500 mV external sensor input range 6 = 250 mV external sensor input range 7 = 50 mV external sensor input range
RV1,m2<terminator>	Sets voltage range.	"m2" indicates voltage range. Values for <i>m2</i> are: 0 = 600 V 1 = 300 V 2 = 150 V 3 = 30 V
SA1,m2<terminator>	Sets the amps scaling constant (current transformer).	"m2" indicates the amps scaling constant in A/A and must be set within the following range: $0.01 < m2 < 10000$ When $m2 = 0$, the amps scaling mode will be cleared.
SV1,m2<terminator>	Sets the voltage scaling constant (potential transformer).	"m2" indicates the voltage scaling constant in V/V and must be set within the following range: $0.01 < m2 < 10000$ When $m2 = 0$, the voltage scaling mode will be cleared.
SE1,m2<terminator>	Sets the external current sensor scaling constant.	"m2" indicates the external current sensor scaling constant in A/mV and must be set within the following range: $0.0001 < m2 < 99999$ NOTE: External sensor voltage input values are divided by this value to give output in amps in external sensor input current ranges.

5.6.2

DATA OUTPUT COMMANDS

Command Code	Function	Explanation
OA1,m2<terminator>	Requests amp measurement value.	"m2" indicates the measurement value. Values for <i>m2</i> are: 0 = normal (RMS/DC depending on measurement mode setting) 1 = peak (instantaneous) 2 = crest factor 3 = peak hold/inrush (RMS/DC)
OV1,m2<terminator>	Requests volt measurement value.	"m2" indicates the measurement value. Values for <i>m2</i> are: 0 = normal (RMS/DC depending on measurement mode setting) 1 = peak (instantaneous) 2 = crest factor 3 = peak hold/inrush (RMS/DC)
OW1,m2<terminator>	Requests watt measurement.	"m2" indicates the measurement value. Values for <i>m2</i> are: 0 = watts 1 = VA 2 = power factor 3 = watts peak hold
OF<terminator>	Requests output of frequency.	---
OE1<terminator>	Requests phase measurement values (amps, volts, watts).	---
OAVE	Retrieves displayed values of current, voltage and power. Returns data in the same format as the OE command.	---
OT<terminator>	Requests all measurement values.	---

6. Calibration

6.1 CLOSED-BOX CALIBRATION

The 6510e features closed-box calibration. The advantage of closed-box calibration is that the user does not have to disassemble the case or make mechanical adjustments.

6.2 CALIBRATION SCHEDULE

Calibrate the 6510e:

- After any repairs are performed.
- At least once a year; more frequently to ensure required accuracy.

6.3 CALIBRATION COMMANDS

Command Code	Function	Explanation
CA1,m2<terminator>	Calibrates amps measurement value of present input range.	"m2" indicates the calibrated input value applied to the input. When <i>m2</i> is equal to 0, the unit assumes zero calibration is requested and zero amps are on input. When <i>m2</i> is greater than 0, the unit assumes gain calibration is requested and <i>m2</i> amps are on input.
CV1,m2<terminator>	Calibrates volts measurement value of present input range.	"m2" indicates the calibrated input value applied to the input. When <i>m2</i> is equal to 0, the unit assumes zero calibration is requested and zero volts are on input. When <i>m2</i> is greater than 0, the unit assumes gain calibration is requested and <i>m2</i> volts are on input.
CS<terminator>	Saves calibration values to EEPROM.	---
CR<terminator>	Restores all calibration values from EEPROM (used for testing only).	---

6.4 BASIC CALIBRATION PROCESS

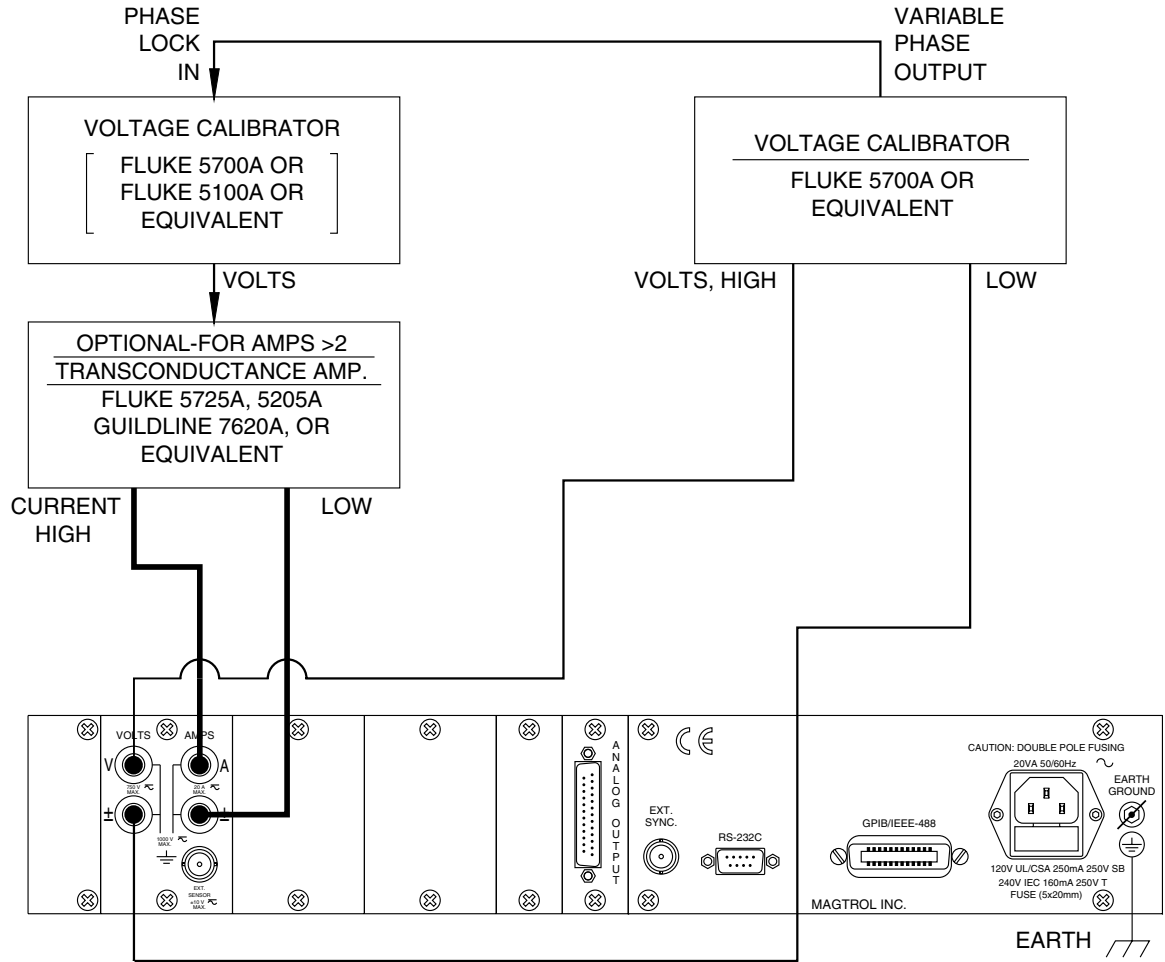

Figure 6-1 Calibration/Verification Test Setup

The 6510e must be used with a personal computer to complete the calibration process.

1. Begin the process with the 6510e turned OFF.
2. Remove any external input connections.
3. Connect the amps and volts.
4. Turn the power ON while holding the SHIFT button. See Section 3.1 – Powering Up the 6510e. Before the display panel shows the segments of the VFD (series of rectangles), the following display will appear indicating that the instrument has been placed in calibration mode.

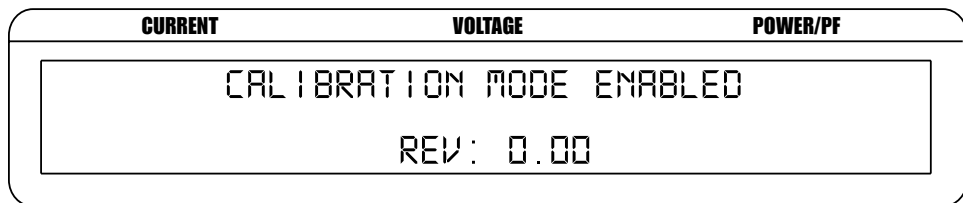

Figure 6-2 Calibration Mode Enabled

MAINTENANCE

5. Set volt and amp range by entering the following command codes.
VOLTS => RV1,m2 where m2 = 0 to 3
AMPS => RA1,m2 where m2 = 0 to 3
6. Set calibrator to 0 volts (DC) and 0 amps (DC).



Note: DC is used for zero.

7. Enter the following commands.
VOLTS => CV1,0
AMPS => CA1,0
8. Set calibrator to full scale range for volts (AC) and amps (AC).



Note: AC 80 Hz is used for gain.

9. Enter the following commands.
VOLTS => CV1,xx.xx
AMPS => CA1,xx.xx
Where xx.xx is the voltage/current on the inputs (full scale).
10. Repeat steps 5 through 9 for all ranges.
11. Remove amp and voltage inputs.
12. Attach external input to calibrator voltage.
13. Set amp range by entering the following command code.
AMPS => RA1,m2 where m2 = 4 to 7
14. Set calibrator to 0 volts (DC).



Note: DC is used for zero.

15. Enter the following command.
AMPS => CA1,0
16. Set calibrator to volts full scale range (AC).



Note: AC 80 Hz is used for gain.

17. Enter the following command.
AMPS => CA1,xx.xx
Where xx.xx is the voltage on the inputs (full scale).
18. Repeat steps 13 through 17 for all ranges.
19. When the calibration for all ranges is complete, enter the CS command to save.

7. Optional Features

7.1 ANALOG OUTPUTS

An option to the 6510e is an analog output plug-in module that provides 12 channels of analog output corresponding to volts, amps and watts. Each output is capable of, and calibrated to, ± 10 volts. The user may apply a scale factor to all outputs by selecting “Analog Outputs” in the USER MENU. See *Section 7.1.4 – Software Configuration*. Amps scaling is applied to all amp channels, volts scaling is applied to all volt channels and watts scaling is applied to all watt channels.

7.1.1 SPECIFICATIONS

- Full scale output range: ± 10 V max.
Number of channels: 12
Output update rate (all channels) = 200 samples/sec (5 ms)

User selectable analog output scaling values are set from the front panel. Amp, volt and watt scaling values correspond to units per analog output volts.

$$(\text{units/output volt}) \times \text{displayed measurement value} = \text{output volts}$$

Examples:

- +15.000 V1 with volts scaling set to 10 V/V = +1.500 V
- -100.00 V1 with volts scaling set to 100 V/V = -1.000 V
- +5.000 A1 with amps scaling set to 1 A/V = +5.000 V
- +123.0 W1 with watt scaling set to 100 W/V = +1.230 V

7.1.2 CHANNEL ASSIGNMENTS

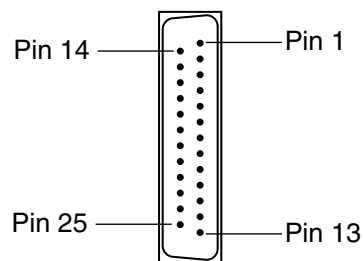

Channel	Input	Pin Number
1	phase 1, amps	1, 14
2	phase 1, volts	2, 15
3	phase 1, watts	3, 16

Figure 7-1 Analog Output

7.1.3 HARDWARE CONNECTION



WARNING: IN PERFORMING THE FOLLOWING PROCEDURE, IT IS ASSUMED THAT PROPER ESD PROTECTION PROCEDURES WILL BE IMPLEMENTED. THE CIRCUITRY INVOLVED IS VERY STATIC SENSITIVE.

If the analog output board is purchased separately, the board will need to be installed in the 6510e with no other setup required. Installation instructions are as follows.

1. Turn the power OFF.
2. Disconnect the line cord.
3. Open the top cover of the unit by unscrewing the top four screws.



Note: Care should be taken when removing the top cover because there is a ground strap attached to it.

4. Disconnect the ground strap from the cover and lay the cover aside.
5. Locate the connector J3 / AUX2.
6. On the back of the 6510e is a cover plate associated with that connector. Remove the cover plate by removing the two screws.
7. Slip the analog output board through the back of the unit and plug it into J3 / AUX2.
8. Using the screws removed from the cover plate, screw the analog output card into position.
9. Replace the top cover by reconnecting the ground strap and replacing the four screws.
10. Finally, plug the line cord in to the back of the unit. When the power is turned on, the 6510e will recognize the card is in place and start sending data to it.

7.1.4 SOFTWARE CONFIGURATION

To configure the 6510e analog output, complete the following steps utilizing the USER MENU located on the front panel of the unit.

1. Turn on the 6510e. See *Section 3.1 – Powering Up the 6510e*.
2. Press ENTER button. The display should appear as shown in *Figure 2–3 Device Setup Menu*.
3. Press ◀ and ▶ buttons until ANALOG OUTPUT appears in the display.
4. Press ENTER button. The display will appear as follows.

CURRENT	VOLTAGE	POWER/PF
0.0000 A/V	0.0000 V/V	0.0000 W/V
AMPS	VOLTS	WATTS

Figure 7–2 Analog Output Setup Menu

5. To set amps value, press the RMS button under AMPS and use the ▲ ▼ ◀ ▶ buttons in the USER MENU to adjust the value.
6. To set volts value, press the RMS button under VOLTS and use the ▲ ▼ ◀ ▶ buttons in the USER MENU to adjust the value.
7. To set watts value, press the AVG button under WATTS and use the ▲ ▼ ◀ ▶ buttons in the USER MENU to adjust the value.
8. Press ENTER to exit the Device Setup Menu.

7.1.5 CALIBRATION

7.1.5.1 Closed-Box Calibration

The 6510e features closed-box calibration for the analog output. The advantage of closed-box calibration is that the user does not have to disassemble the case or make mechanical adjustments.

7.1.5.2 Calibration Schedule

Calibrate the 6510e analog output board:

- After any repairs are performed.
- At least once a year; more frequently to ensure required accuracy.

7.1.5.3 Calibration Commands

The following commands are accessible when the instrument is placed in calibration mode by holding the SHIFT key while the power is turned on. “CALIBRATION MODE ENABLED” will appear on the display.



Note: If the unit has not been placed in calibration mode, all calibration commands will return “CAL DISABLED” response.

Response to all analog output calibration commands:

Default: output_string = <NULL_STRING (0x00) ><terminator>

Command Code	Function	Explanation
CMm<terminator>	Sets calibration mode for analog output D/A channels.	"m" indicates calibration mode OFF/ON. Values for <i>m</i> are: 0 = D/A calibration mode OFF (normal output mode) 1 = Set all D/A output channels to Positive Full Scale. (+10 V nominal) 2 = Set all D/A output channels to Negative Full Scale. (-10 V nominal)
CGm1,m2<terminator>	Calibrates D/A output channel gain.	"m1" indicates D/A channel (1-3). "m2" indicates the measured D/A channel output voltage (positive or negative full scale depending on calibration mode)."

7.1.5.4 Basic Calibration Process

1. Turn on the unit with SHIFT button pressed.
2. Send CM1 command. This sets all DAC outputs to 10 volts nominal.
3. Using a volt meter, measure the voltage on the channel.
4. Send the appropriate CG command. See *Section 7.1.5.3 – Calibration Commands*.
5. Repeat steps 3 and 4 until all 3 channels are complete.
6. Send CM2 command. This sets all DAC outputs to -10 volts nominal.
7. Using a volt meter, measure the voltage on the channel.
8. Send the appropriate CG command. See *Section 7.1.5.3 – Calibration Commands*.
9. Repeat steps 7 and 8 until all 3 channels are complete.
10. Send CX command to save calibration values.

8. Troubleshooting

Problem	Reason	Solution
Display indicates I/O ERROR.	Command does not match the unit's programmed set of instructions.	Use correct command and format.
No GPIB communication.	Setup error and/or hardware fault.	Check: <ul style="list-style-type: none">• GPIB address of power analyzer.• GPIB cable - should be functioning and attached to power analyzer and computer interface card.
No RS-232 communication.	Setup error and/or hardware fault.	Check: <ul style="list-style-type: none">• Baud rate of power analyzer.• Pinout of serial cable.• Cable attachment to power analyzer and serial interface port of computer.

If you require additional assistance, please contact Magtrol Customer Service at 1-716-668-5555.

Appendix A: Schematics

A.1 MAIN BOARD - DSP, RAM, FLASH

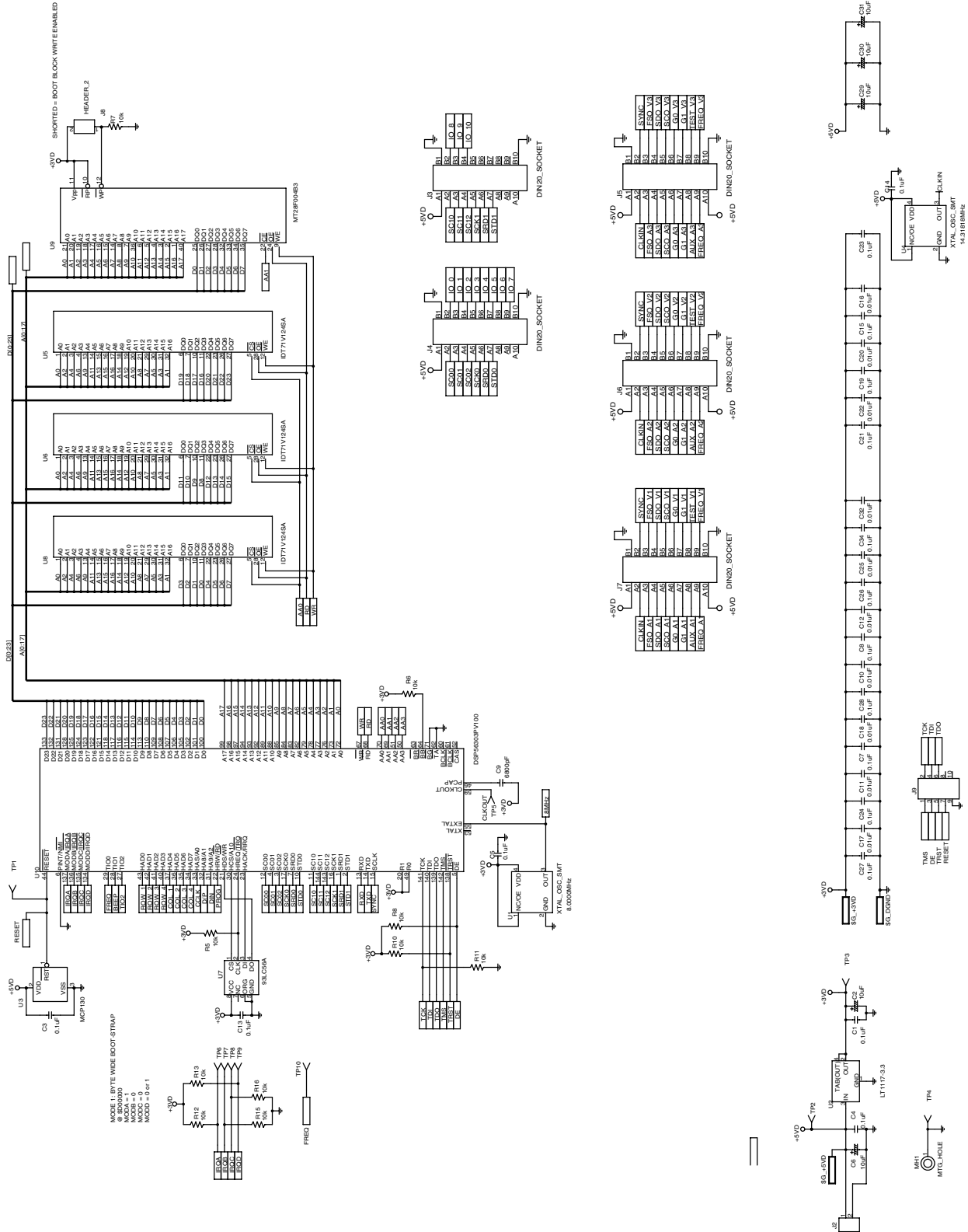

A.2 MAIN BOARD - INPUT/OUTPUT, GPIB, RS-232

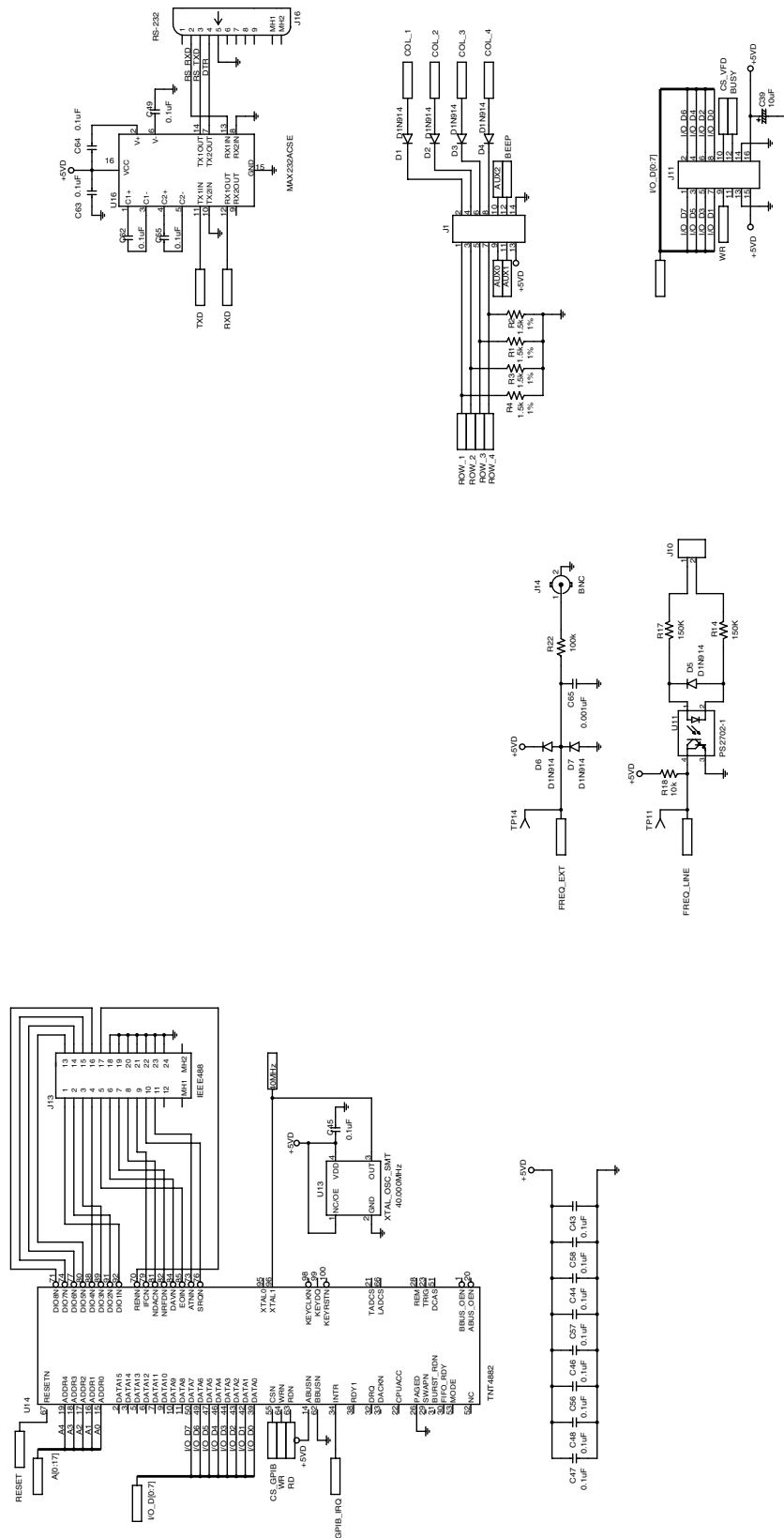

A.3 MAIN BOARD - FPGA

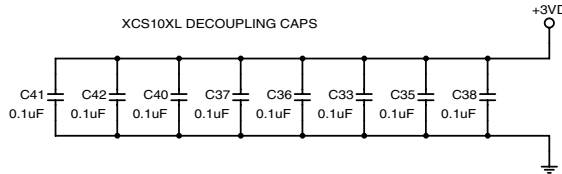
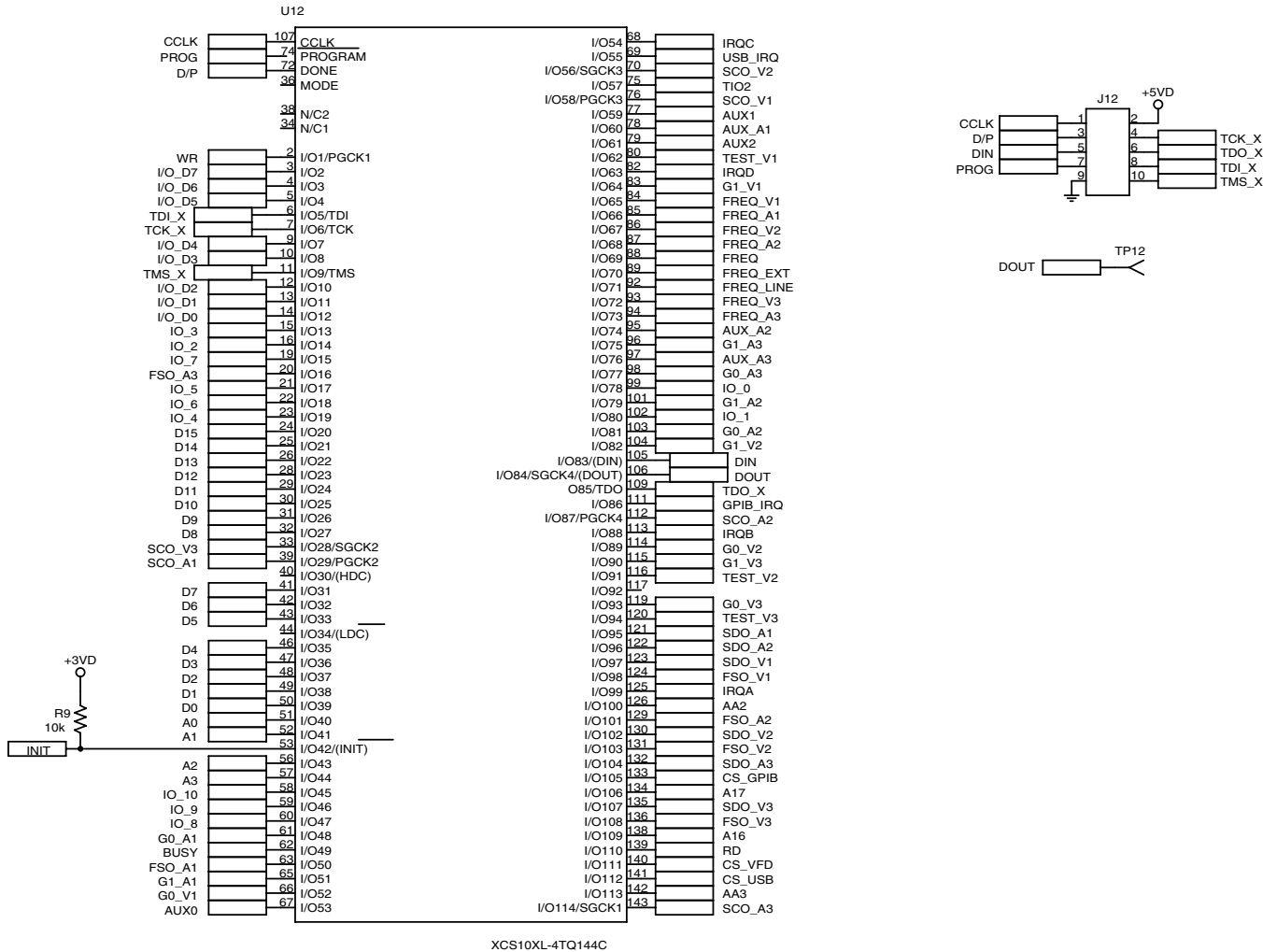

A.4 INPUT MODULE - CURRENT

4th Order Chebyshev 500 Hz LPF zero cross detector with hysteresis

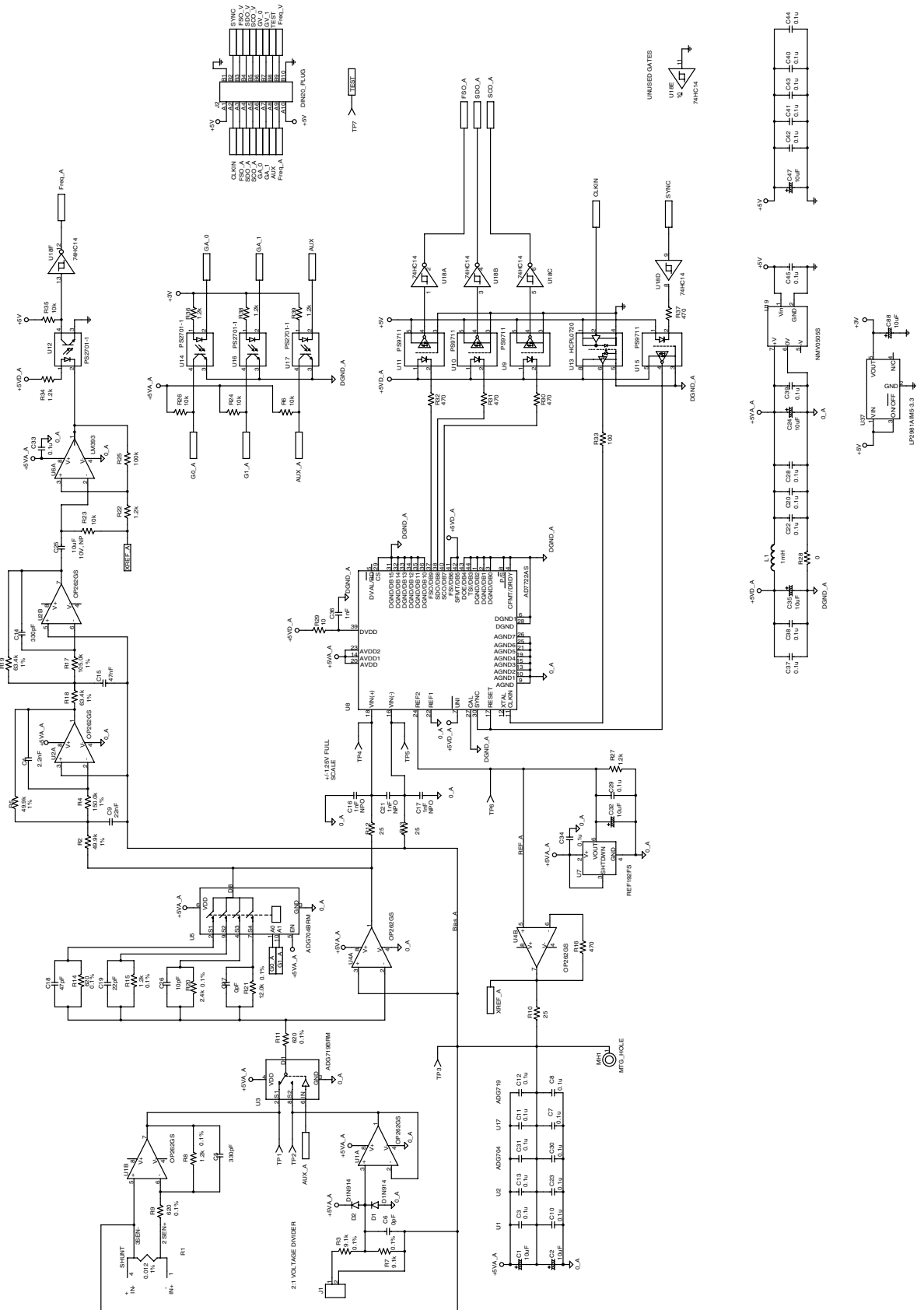

A.5 INPUT MODULE - VOLTAGE

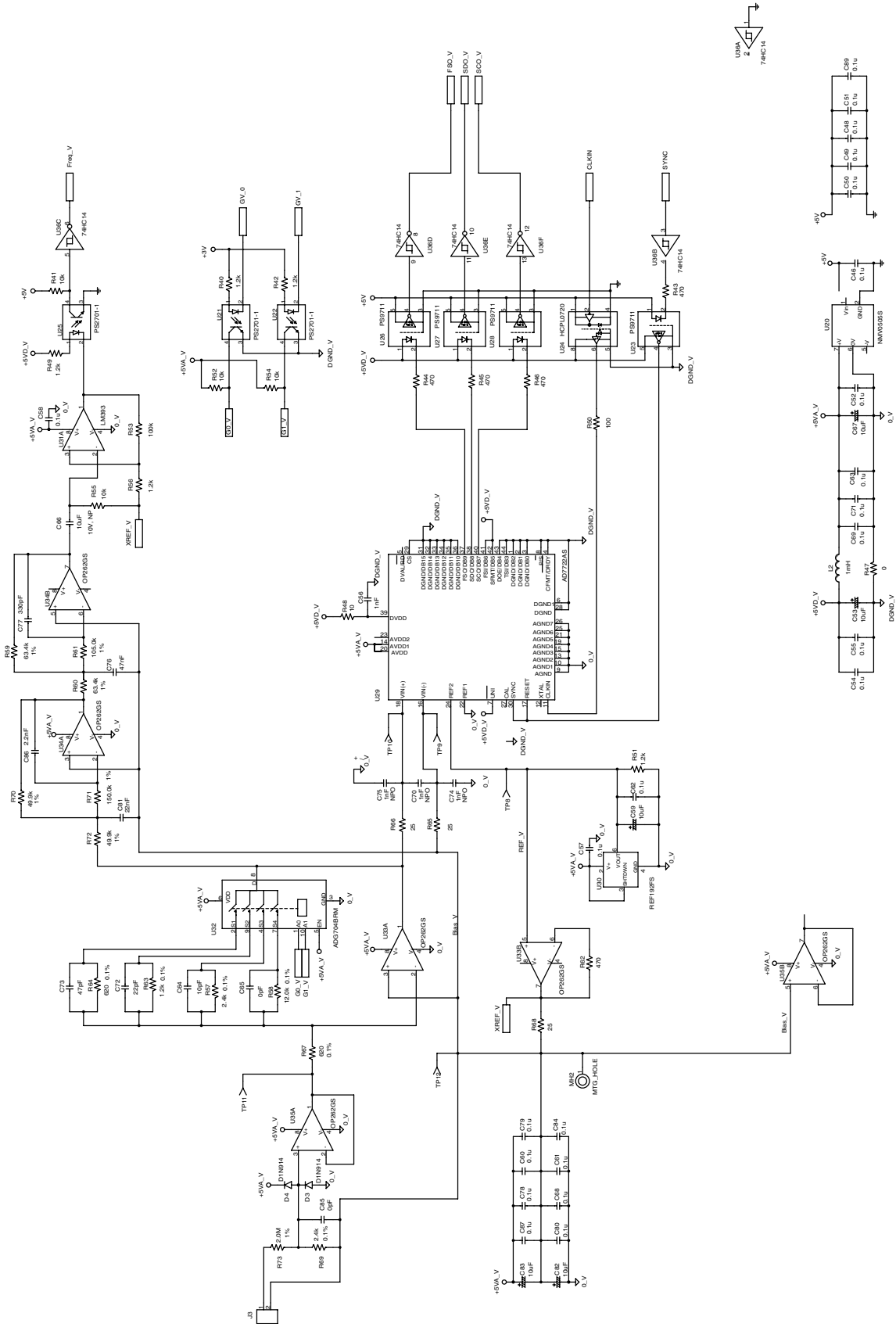

A.6 KEY PAD

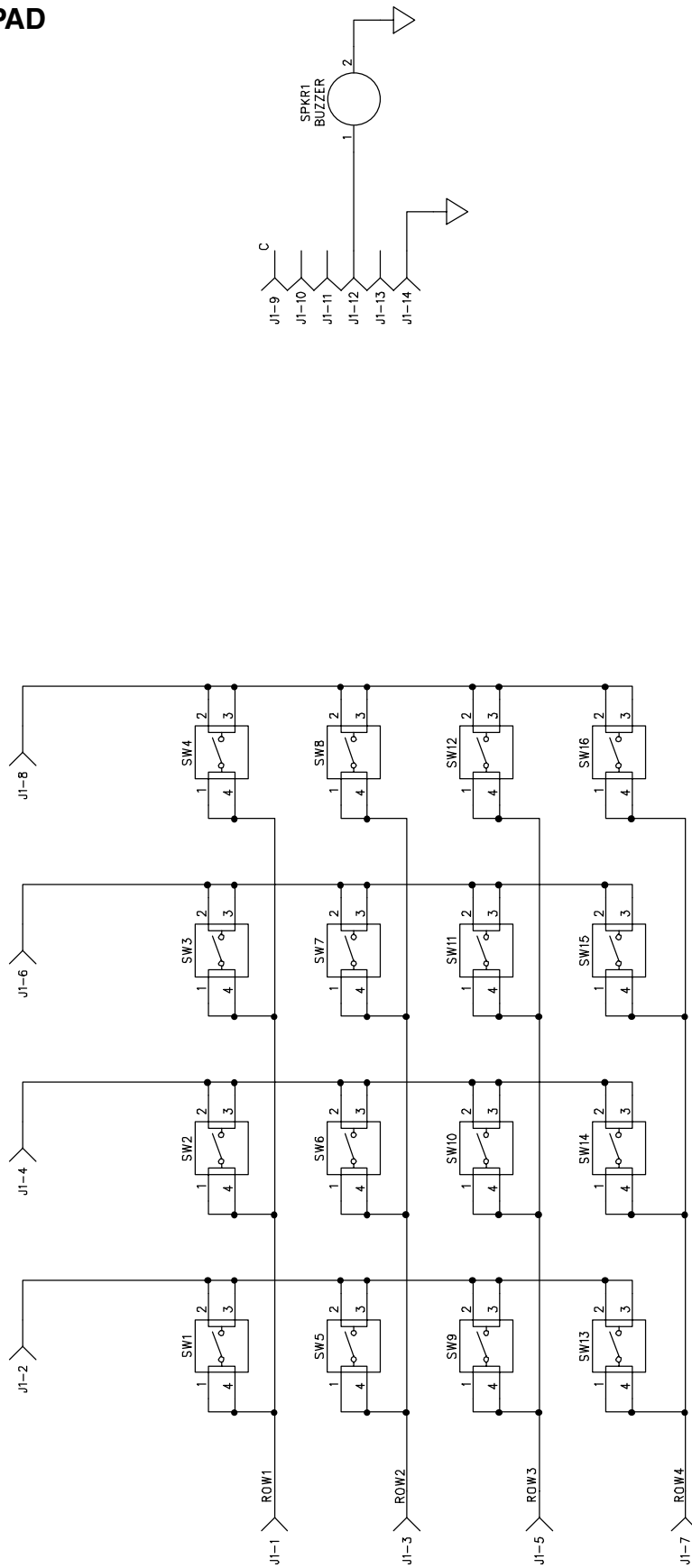

A.7 ANALOG OUTPUT

A.7.1 Analog Output – drawing 1 of 4

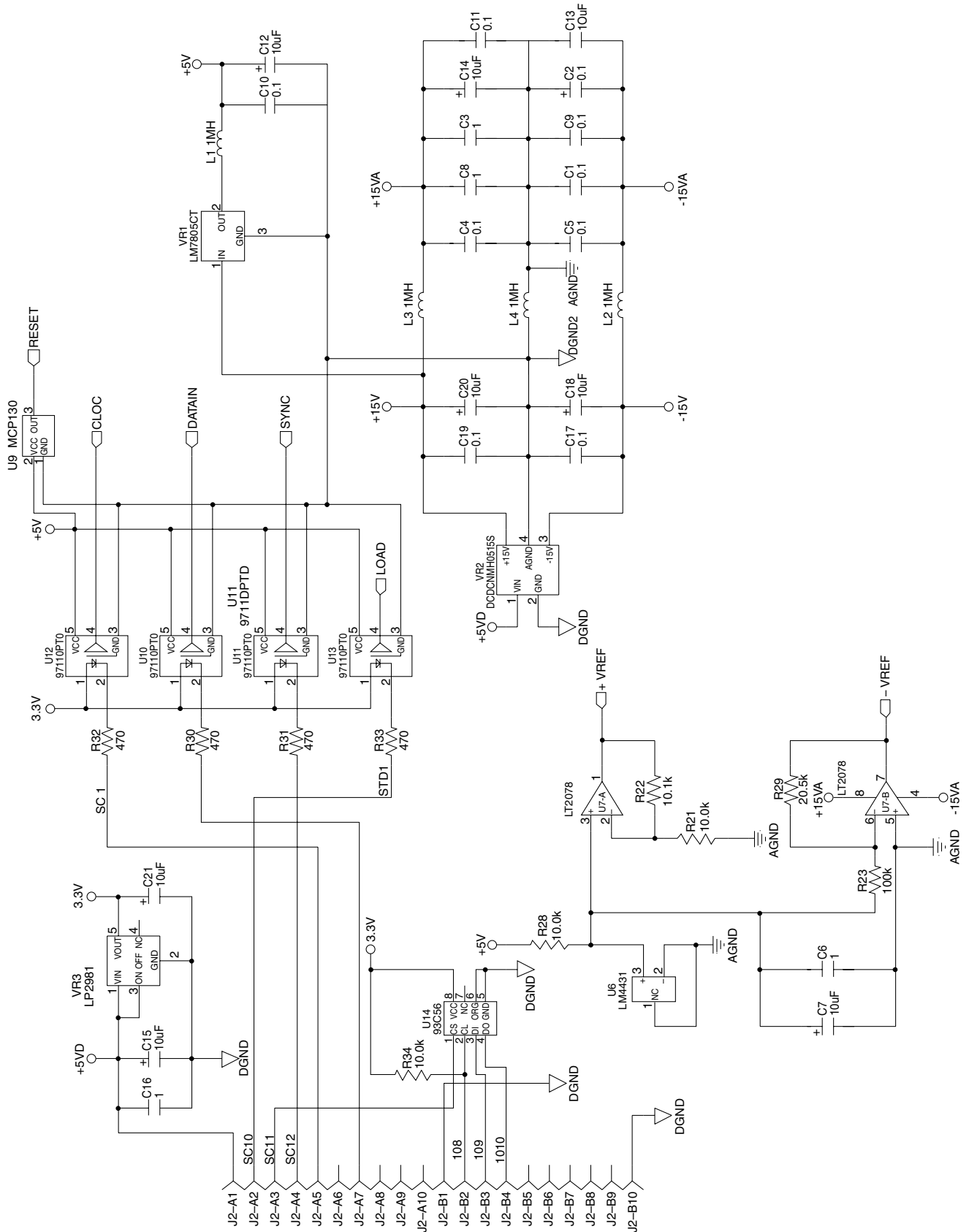

A.7.2 Analog Output – drawing 2 of 4

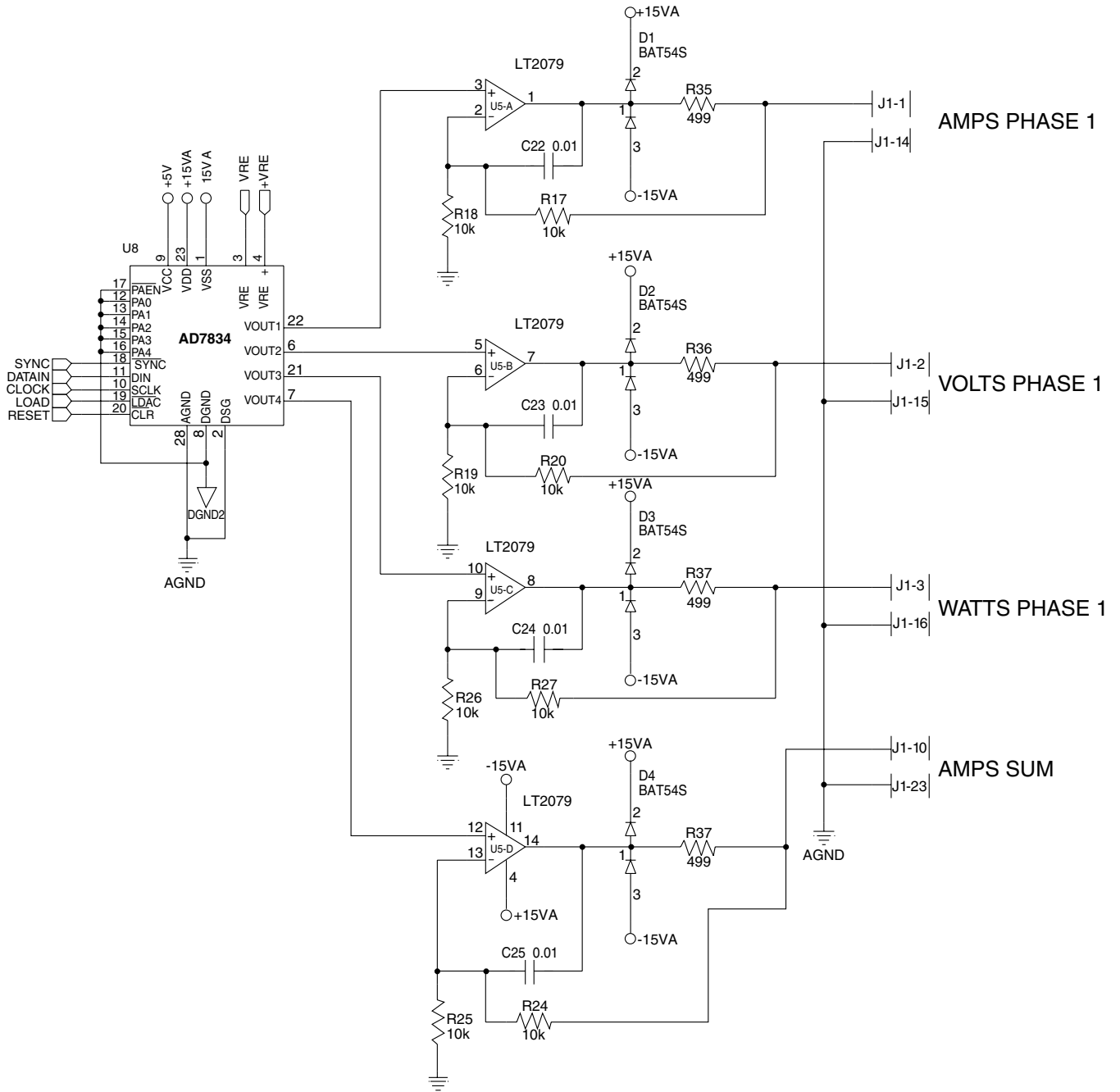

A.7.3 Analog Output – drawing 3 of 4

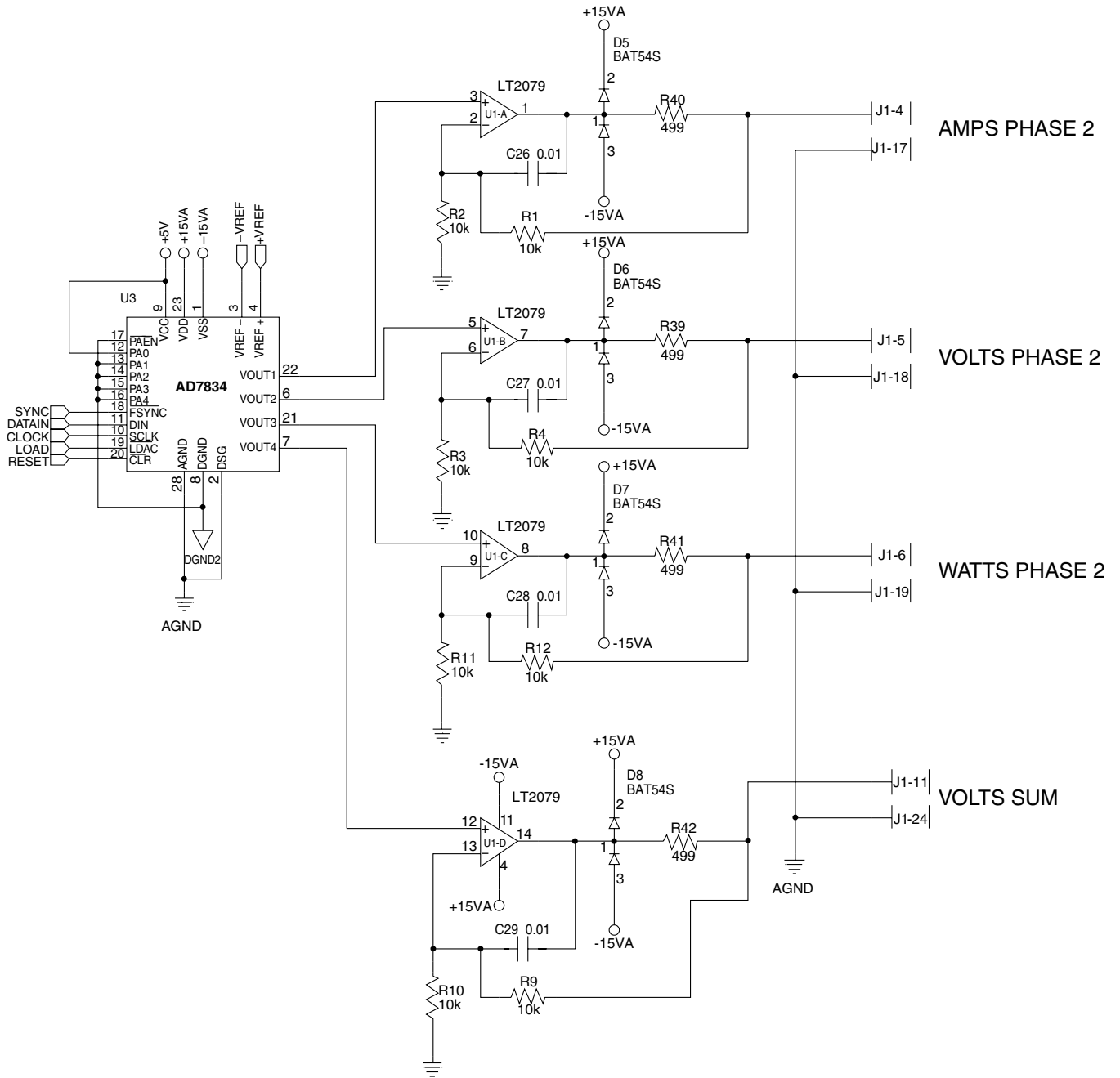

A.7.4 Analog Output – drawing 4 of 4

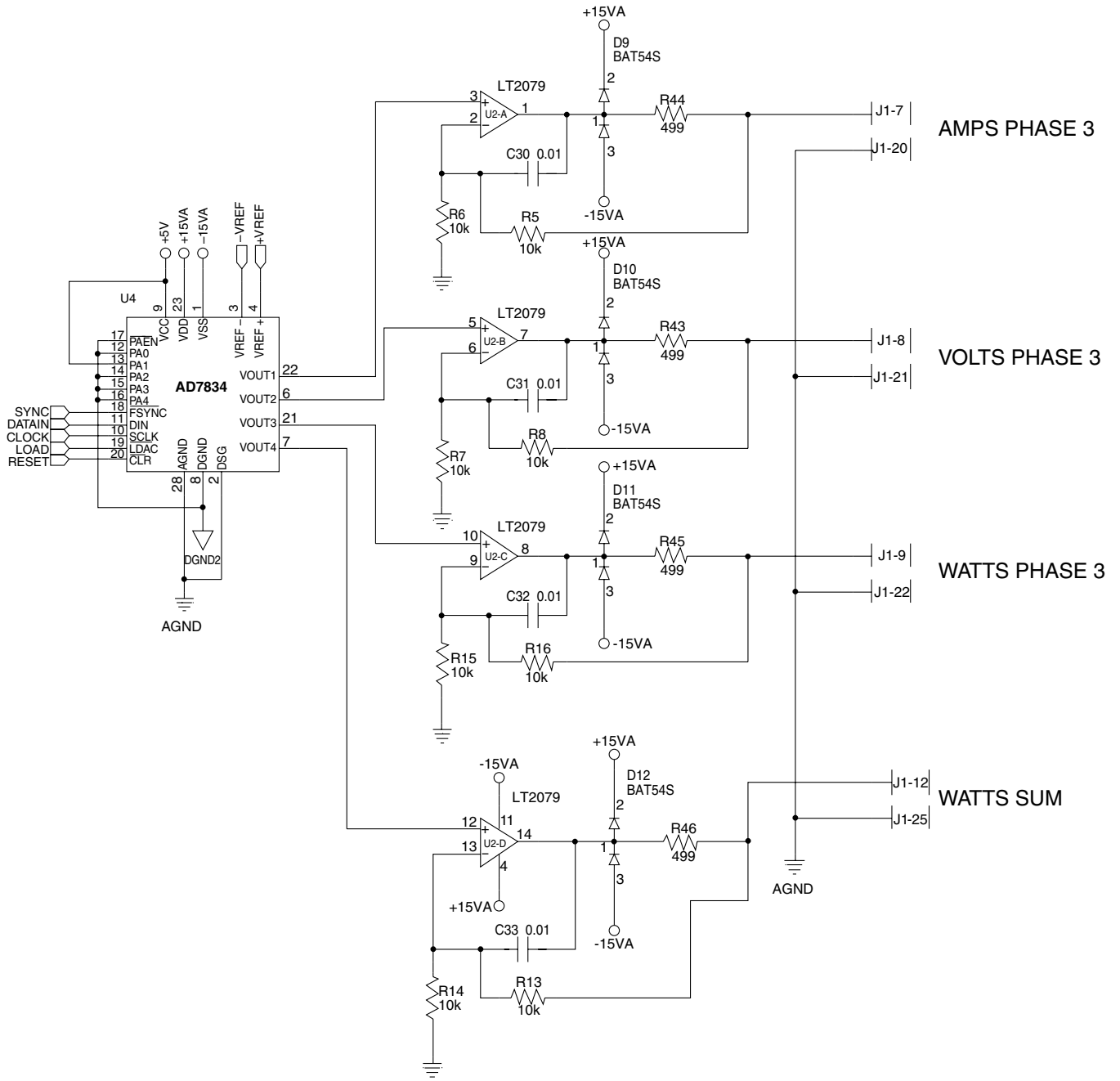

Glossary

Following is a list of abbreviations and terms used in this manual. For a list of symbols and abbreviations used on the 6510e display, refer to *Section 2.3.2 – Display Guide*.

- Active Power**The sum of the instantaneous volts input multiplied by the instantaneous amps input = true power = watts.
- Apparent Power**The product of volts root mean square and amps root mean square.
- DSP**Digital Signal Processing
- EXT. SYNC.**External Synchronization. Using an external source to synchronize the measurements in cycle-by-cycle mode.
- GPIB**General Purpose Interface Bus. IEEE-488 Instrument Bus Standard.
- IEEE**Institute of Electrical and Electronics Engineers. Organization best known for developing standards for the computer and electronics industry.
- Inrush (↑)**The initial current that is drawn when an electronic device is turned on. The inrush current can be substantially higher in magnitude than when the circuit is at its steady state.
- MOV**Metal Oxide Varistor – transient suppressor, needed when inductive loads are used.
- PA**Power Analyzer
- PC**Personal Computer
- PF**Power Factor = $\text{COS}\varnothing = \text{True Power}/(\text{V}_{\text{rms}} \times \text{I}_{\text{rms}})$
- RMS**Root Mean Square
- RS-232**Recommended Standard-232C, a standard interface approved by the Electronic Industries Association (EIA) for connecting serial devices.
- True Power**The sum of the instantaneous volts input multiplied by the instantaneous amps input = active power = watts.
- VA**Volt Amperes
- W**Watts = $\text{V}_{\text{rms}} \times \text{I}_{\text{rms}} \times \text{COS}\varnothing = \text{True Power} = \text{Active Power}$, where \varnothing is the phase angle between V and I.

Index

A

Abbreviations Used 9
Active Power 63
Amp Scaling 21
Amp Scaling Setup Menu 21
Amps Gain 28
Amps Input 10
Amps Signal 28
Analog Output 11
 Hardware Connection 49
 Setup Menu 49
 Software Configuration 49
Analog Outputs 48
Analog Processing 27
Apparent Power 63
Average Mode 25

B

Baud Rate 39
Buttons 5,6

C

Calibration 50
 Commands 45,50
 Mode 46
 Process 46,51
 Schedule 45,50
 Setup 46
Channel Assignments 48
Circuit Breakers 16
Closed-Box Calibration 45,50
Commands
 Calibration 45,50
 Configuration 42
 Data Output 44
Communication Commands 42
Communication Parameters 39
Configuration Commands 42
Connection
 6530-to-PC 39
 Analog Output Board 49
 RS-232 38
Continuous Mode 36
Contrast Settings 8
Controls 5,6
Crest Factor 36
Current
Current/Potential Transformer Connection 21
Current Overload 15
Custom Display 26
Custom Main Menu 14
Cycle-by-Cycle Mode 24,36

D

Data Format 40
Data Output Commands 44
Data Sheet 2
Data Termination Characters 41
Digital Processing 29

E

Ext. Sync. 11,63
External Sensor 10,19
External Sensor Scale Factor Setup Menu 20
External Shunt 29

F

Features 1
Front Panel 5

G

Gain
 Amps 28
 Volts 27
GPIB
 Installation 37
 Primary Address 37
GPIB/IEEE-488 11
GPIB Interface 37

H

Hold Mode 25

I

Input Module 10
Inputs 10
 Amps Input 10
 Ext. Sync. 11
 External Sensor 10
 Voltage Input 10
Inrush 63
Inrush Current 35
Interrupt Driven
 AC 30
 DC 32

L

Line Voltage 13

M

Main Menu 14
Main Program
 AC 31
 DC 33

Measurement Filter 18
Measurement Methods 36
Measurement Modes 34
Menus
 Amp Scaling Setup Menu 21
 Analog Output Setup Menu 49
 Custom Main Menu 14
 External Sensor Scale Factor Setup Menu 20
 Main Menu 14
 Phase Main Menu 14
 Volt Scaling Setup Menu 23
Metal Oxide Varistor 15,63

O

Output Amps 41
Output Element 41
Output Frequency 41
Outputs 10
 Analog Output 11
Output Total 40
Output Volts 41
Output Watts 41

P

Peak 34
Peak Hold 26,35
Phase Main Menu 14
Phase Setup 24
Primary Address 37
Programming 41

R

Rear Panel 10
Remote Voltage Sense 16
RMS 36,63
Round-Off Error 34
RS-232
 Connection 38
RS-232C 11
RS-232 Interface 38

S

Scaling Activated 22
Secondary Functions 6
Self-Test 13
Sensor Substitution 19
Setup 17
Signal
 Amps 28
 Volts 27
Surge Protection 15
Symbols Used 9

T

Testing Instrumentation Setup 17
Transient Overloads 15
Transient Voltage Suppression 16
Troubleshooting 52

U

Unpacking 1

V

Vacuum Fluorescent Display 8
Voltage Gain 27
Voltage Input 10
Voltage Signal 27
Volt Scaling Setup Menu 23
Volts Scaling 23

W

Wiring Modes 17–26



Testing, Measurement and Control of Torque-Speed-Power • Load-Force-Weight • Tension • Displacement

