

DIMENSIONS

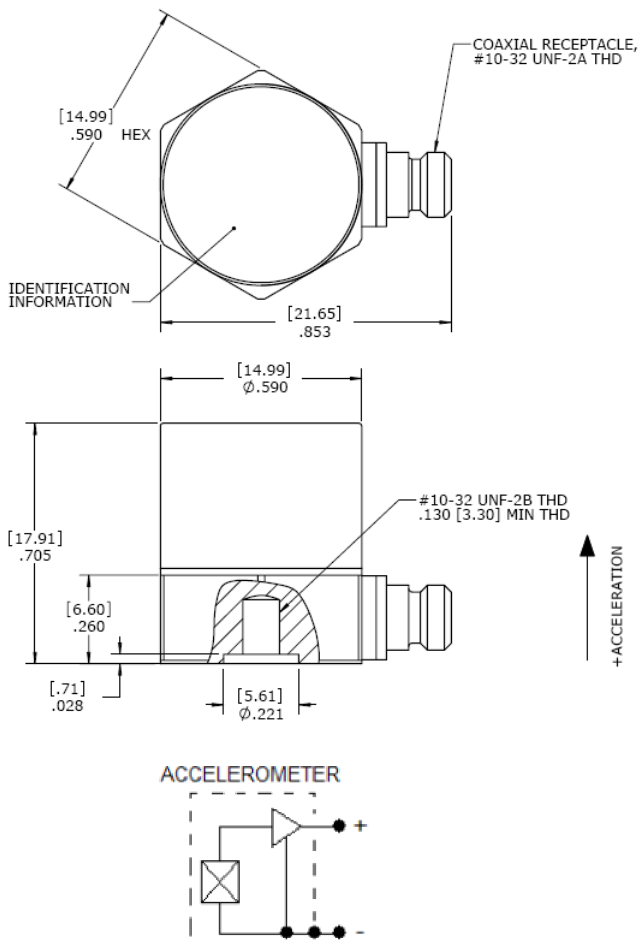

MODEL 7114A ACCELEROMETER

SPECIFICATIONS

- IEPE Accelerometer
- High Sensitivity, 1000mV/g
- 10-32 Side Connector
- Stud Mount, Hermetic

The Model 7114A is a high performance IEPE accelerometer available in $\pm 5g$ to $\pm 50g$ dynamic ranges. The stud mounted accelerometer features a welded hermetic construction with a side mount connector. The model 7114A incorporates stable piezo-ceramic crystals in annular shear mode which provide a wide bandwidth. The standard operating temperature range extends from -55°C to $+125^{\circ}\text{C}$. For a miniature stud mount version please review model 7104A, available in $\pm 50g$ to $\pm 500g$ dynamic ranges.

FEATURES

- $\pm 5g$ to $\pm 50g$ Dynamic Range
- High Sensitivity, 1000mV/g
- Welded Construction
- Hermetically Sealed
- Annular Shear Mode
- Stable Temperature Response

APPLICATIONS

- Vibration & Shock Monitoring
- Laboratory Testing
- Modal Applications
- High Frequency Applications
- General Purpose Usage

PERFORMANCE SPECIFICATIONS

All values are typical at +24°C, 80Hz and 4mA excitation unless otherwise stated. Measurement Specialties reserves the right to update and change these specifications without notice.

Parameters

DYNAMIC

| | ±5 | ±10 | ±50 | Notes |
|----------------------------|----------|----------|----------|------------------------|
| Range (g) | ±5 | ±10 | ±50 | |
| Sensitivity (mV/g) | 1000 | 500 | 100 | |
| Frequency Response (Hz) | 1-4000 | 1-5000 | 1-8000 | ±5% |
| Frequency Response (Hz) | 0.5-5000 | 0.5-6000 | 0.5-9000 | ±1dB |
| Natural Frequency (Hz) | 26000 | 28000 | 30000 | |
| Phase Response (Hz) | 1-2000 | 1-2000 | 1-2500 | <5° |
| Non-Linearity (%FSO) | ±1 | ±1 | ±1 | |
| Transverse Sensitivity (%) | <5 | <5 | <5 | |
| Shock Limit (g) | 5000 | 5000 | 5000 | |
| Residual Noise (g RMS) | 0.0001 | 0.0002 | 0.0004 | Broadband 1Hz to 10kHz |

ELECTRICAL

| | | | | |
|--------------------------------------|---------------|--|--|------------------|
| Compliance Voltage (Vdc) | 18 to 30 | | | |
| Excitation Current (mA) ¹ | 2 to 10 | | | See Note 1 |
| Bias Voltage (Vdc) | 8 to 12 | | | Room Temperature |
| Bias Voltage (Vdc) | 6 to 13 | | | -55 to +125°C |
| Output Impedance (Ω) | <100 | | | |
| Full Scale Output Voltage (V) | ±5 | | | |
| Discharge Time Constant (sec) | 0.8 to 1.2 | | | |
| Grounding | Case Grounded | | | |

ENVIRONMENTAL

| | |
|----------------------------|---------------------------|
| Temperature Response (%) | ±5 |
| Operating Temperature (°C) | -55 to +125 |
| Storage Temperature (°C) | -55 to +125 |
| Humidity | Hermetically Sealed, IP67 |

PHYSICAL

| | |
|-----------------|---|
| Sensing Element | Ceramic (shear mode) |
| Case Material | Stainless Steel |
| Weight (grams) | 19 |
| Mounting | #10-32 to #10-32 Mounting Stud (included) |
| Mounting Torque | 18 lb-in (2.0 N-m) |

¹ Maximum 4mA at +125°C

| | | |
|------------------------------|--------------|---|
| Calibration supplied: | CS-FREQ-0100 | NIST Traceable Amplitude Calibration from 20Hz to ±1dB Frequency Response Limit |
| Supplied accessories: | AC-D02298 | 10-32 to 10-32 mounting stud |
| Optional accessories: | 310-XXX | Cable Assembly, 10-32 to 10-32 (XXX designates length in inches, 10ft standard) |
| | 314-XXX | Cable Assembly, 10-32 to BNC (XXX designates length in inches, 10ft standard) |
| | AC-A03470 | Adhesive Mounting Adaptor |
| | AC-A03471 | Magnetic Mounting Adaptor |
| | 161A | 4-Channel PE & IEPE Signal Conditioner |

The information in this sheet has been carefully reviewed and is believed to be accurate; however, no responsibility is assumed for inaccuracies. Furthermore, this information does not convey to the purchaser of such devices any license under the patent rights to the manufacturer. Measurement Specialties, Inc. reserves the right to make changes without further notice to any product herein. Measurement Specialties, Inc. makes no warranty, representation or guarantee regarding the suitability of its product for any particular purpose, nor does Measurement Specialties, Inc. assume any liability arising out of the application or use of any product or circuit and specifically disclaims any and all liability, including without limitation consequential or incidental damages. Typical parameters can and do vary in different applications. All operating parameters must be validated for each customer application by customer's technical experts. Measurement Specialties, Inc. does not convey any license under its patent rights nor the rights of others.

ORDERING INFORMATION

PART NUMBERING Model Number+Range

7114A-GGGG
|_____ Range (0050 is 50g)

Example: 7114A-0050
Model 7114A, 50g

TE.com/sensorsolutions

Measurement Specialties, Inc., a TE Connectivity company.

Measurement Specialties, TE Connectivity, TE Connectivity (logo) and EVERY CONNECTION COUNTS are trademarks. All other logos, products and/or company names referred to herein might be trademarks of their respective owners.

The information given herein, including drawings, illustrations and schematics which are intended for illustration purposes only, is believed to be reliable. However, TE Connectivity makes no warranties as to its accuracy or completeness and disclaims any liability in connection with its use. TE Connectivity's obligations shall only be as set forth in TE Connectivity's Standard Terms and Conditions of Sale for this product and in no case will TE Connectivity be liable for any incidental, indirect or consequential damages arising out of the sale, resale, use or misuse of the product. Users of TE Connectivity products should make their own evaluation to determine the suitability of each such product for the specific application.

© 2015 TE Connectivity Ltd. family of companies All Rights Reserved.