

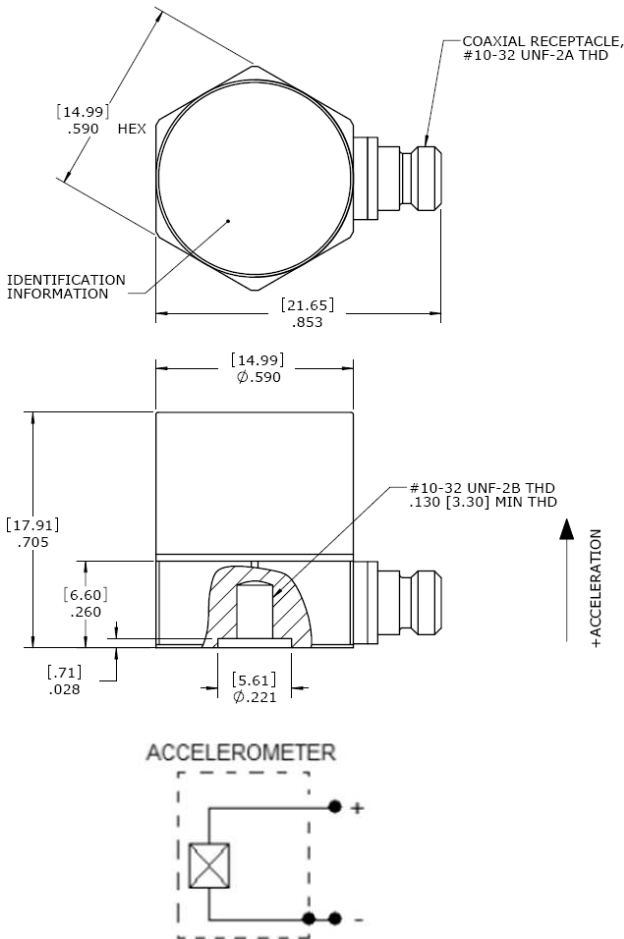

DIMENSIONS



MODEL 7514A ACCELEROMETER

SPECIFICATIONS

- +260°C Charge Output Accelerometer
- 50pC/g output, 14kHz Bandwidth
- Hermetically Sealed
- Stud Mount, Side Connector

The Model 7514A is a stud mounted piezoelectric charge mode accelerometer with an operating temperature range to +260°C. The accelerometer is designed for high frequency vibration and shock measurements and offers a wide bandwidth to >14kHz with a nominal charge output of 50pC/g. The model 7514A features a hermetically sealed stainless steel housing and a #10-32 stud mount configuration.

FEATURES

- 13pC/g to 50pC/g Sensitivity
- Wide bandwidth up to >14kHz
- Stud Mounted
- Hermetically Sealed
- Annular Shear Mode
- -73°C to +260°C Operating Range
- Stable Temperature Response

APPLICATIONS

- Vibration & Shock Monitoring
- High Temp Applications
- Laboratory Testing
- High Frequency Applications
- Gearbox Vibration Monitoring

PERFORMANCE SPECIFICATIONS

All values are typical at +24°C, 80Hz unless otherwise stated. Measurement Specialties reserves the right to update and change these specifications without notice.

Parameters					Notes
DYNAMIC					
Dash Number	-50	-30	-20	-13	
Sensitivity (pC/g)	50	30	20	13	Typical
Sensitivity (pC/g)	40	24	14.5	9.0	Minimum
Frequency Response (Hz) ²	0.5-6000	0.5-7000	0.5-9000	0.5-11000	±10%
Frequency Response (Hz) ²	0.1-9000	0.1-10000	0.1-12000	0.1-14000	±2dB
Natural Frequency (Hz)	26000	28000	30000	33000	
Non-Linearity (%FSO)	±1/1000g	±1/1000g	±1/1000g	±1/1000g	
Transverse Sensitivity (%)	<5	<5	<5	<5	
Dynamic Range (g) ¹	±500	±800	±1250	±2000	
Shock Limit (g)	10000	10000	10000	10000	
Weight (grams)	25	22	20	19	

ELECTRICAL		
Capacitance (pF)	1050	Nominal
Insulation Resistance (MΩ)	>100	@100Vdc
Grounding	Case Grounded	

ENVIRONMENTAL	
Temperature Response (%)	See Typical Temperature Response Curve
Operating Temperature (°C)	-73 to +260
Storage Temperature (°C)	-73 to +260
Humidity	Hermetically Sealed, IP67

PHYSICAL	
Sensing Element	Ceramic (shear mode)
Case Material	Stainless Steel
Electrical Connector	10-32 Coaxial Receptacle
Mounting	#10-32 to #10-32 Mounting Stud (included)
Mounting Torque	18 lb-in (2.0 N-m)

¹ Operating range over which the accelerometer meets the linearity specifications
² Low-end response of the accelerometer is a function of its associated electronics.

Calibration supplied:	CS-FREQ-0100	NIST Traceable Amplitude Calibration from 20Hz to ±2dB Frequency Response Limit
Supplied accessories:	AC-D02298	10-32 to 10-32 mounting stud
Optional accessories:	320-XXX	Cable Assembly, 10-32 to 10-32 (XXX designates length in inches, 10ft standard)
	324-XXX	Cable Assembly, 10-32 to BNC (XXX designates length in inches, 10ft standard)
	130	In-Line Charge Converter
	161A	4-Channel PE & IEPE Signal Conditioner
	AC-A03470	Adhesive Mounting Adaptor
	AC-A03471	Magnetic Mounting Adaptor

The information in this sheet has been carefully reviewed and is believed to be accurate; however, no responsibility is assumed for inaccuracies. Furthermore, this information does not convey to the purchaser of such devices any license under the patent rights to the manufacturer. Measurement Specialties, Inc. reserves the right to make changes without further notice to any product herein. Measurement Specialties, Inc. makes no warranty, representation or guarantee regarding the suitability of its product for any particular purpose, nor does Measurement Specialties, Inc. assume any liability arising out of the application or use of any product or circuit and specifically disclaims any and all liability, including without limitation consequential or incidental damages. Typical parameters can and do vary in different applications. All operating parameters must be validated for each customer application by customer's technical experts. Measurement Specialties, Inc. does not convey any license under its patent rights nor the rights of others.

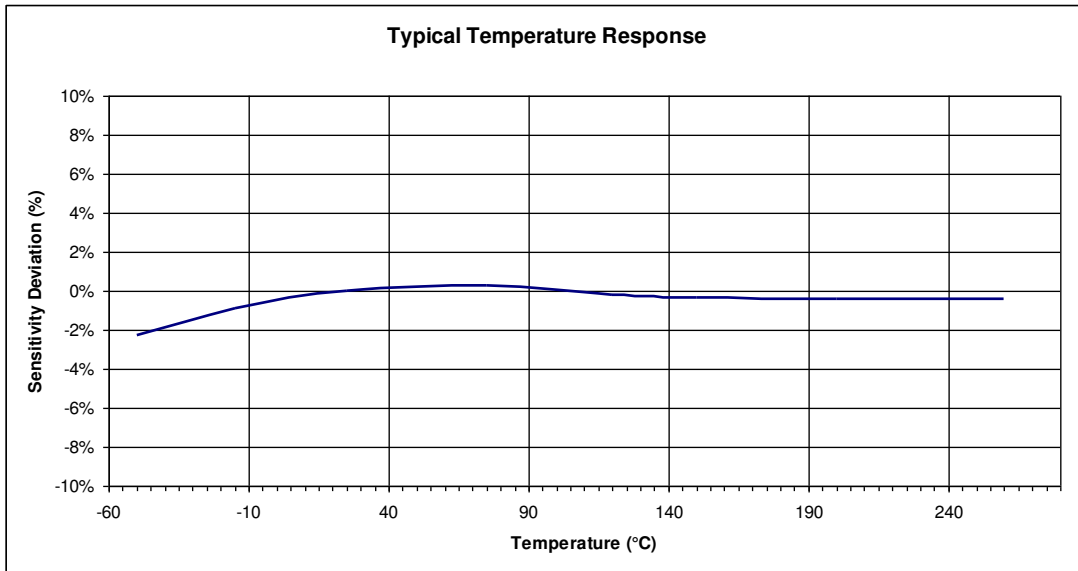
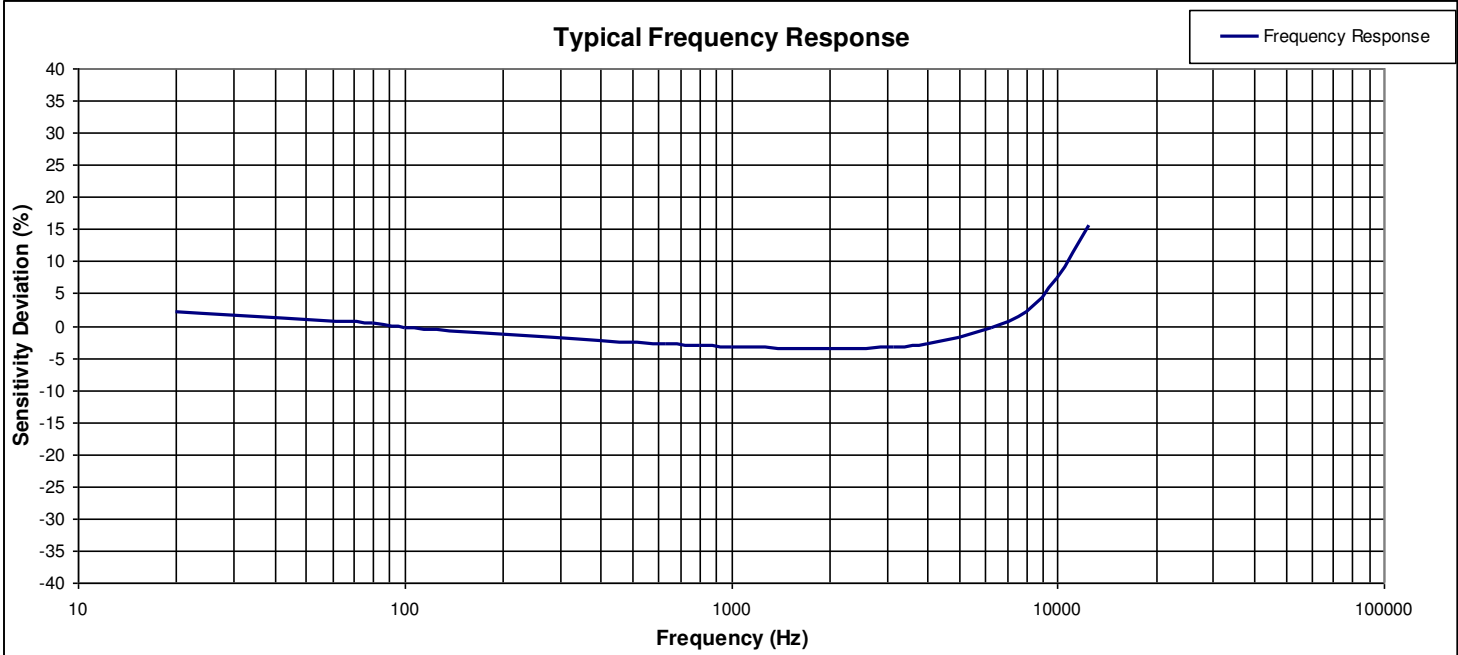

ORDERING INFORMATION

PART NUMBERING Model Number+Sensitivity

7514A-GG

I_____ (50 is 50pC/g)

Example: 7514A-50

Model 7514A, 50pC/g

TE.com/sensorsolutions

Measurement Specialties, Inc., a TE Connectivity company.

Measurement Specialties, TE Connectivity, TE Connectivity (logo) and EVERY CONNECTION COUNTS are trademarks. All other logos, products and/or company names referred to herein might be trademarks of their respective owners.

The information given herein, including drawings, illustrations and schematics which are intended for illustration purposes only, is believed to be reliable. However, TE Connectivity makes no warranties as to its accuracy or completeness and disclaims any liability in connection with its use. TE Connectivity's obligations shall only be as set forth in TE Connectivity's Standard Terms and Conditions of Sale for this product and in no case will TE Connectivity be liable for any incidental, indirect or consequential damages arising out of the sale, resale, use or misuse of the product. Users of TE Connectivity products should make their own evaluation to determine the suitability of each such product for the specific application.

© 2015 TE Connectivity Ltd. family of companies All Rights Reserved.