



MODEL 832 ACCELEROMETER

SPECIFICATIONS

- Triaxial Piezoelectric Accelerometer
- <math><4\mu\text{A}</math> Current Consumption
- Full Signal and Power Conditioning
- Circuit Board Mountable

The Model 832 is a low cost, board mountable triaxial accelerometer. Featuring stable piezo-ceramic crystals, the accelerometer incorporates full power and signal conditioning with a maximum current consumption of 4 micro-amps. The model 832 is available in $\pm 25\text{g}$ to $\pm 500\text{g}$ ranges and provides a flat frequency response up to 2kHz. The model 832M1 provides an extended frequency range to 6kHz.

DIMENSIONS

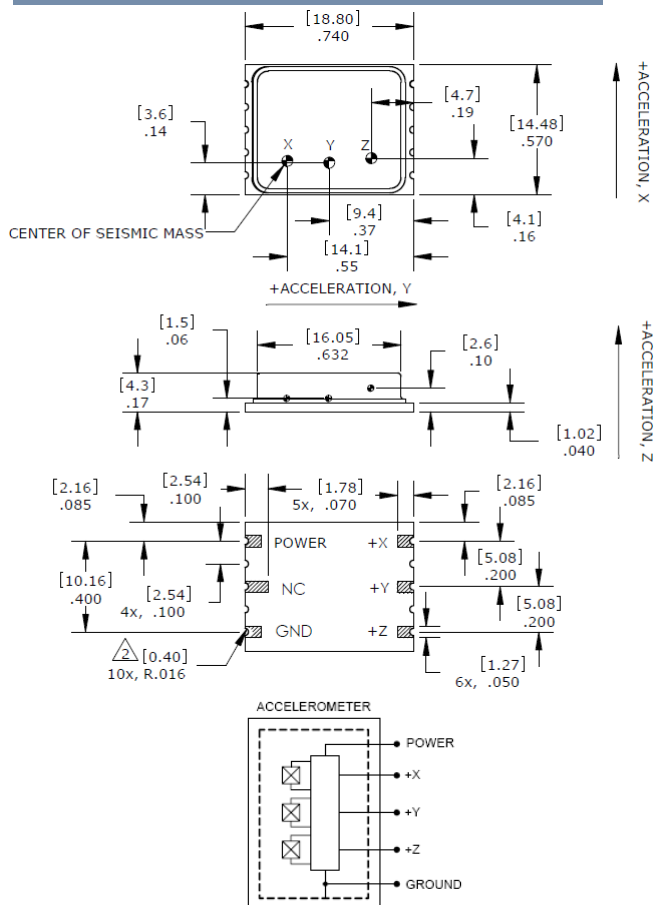

FEATURES

- $\pm 25\text{g}$ to $\pm 500\text{g}$ Dynamic Range
- Low Cost Triaxial
- Hermetically Sealed
- Piezo-ceramic Crystals
- -20° to $+80^\circ\text{C}$ Operating Range
- -40° to $+125^\circ\text{C}$ Available on 832M1
- Single Axis Configurations Available

APPLICATIONS

- Asset Monitoring
- Data Loggers
- Impact Monitoring
- Machine Health Monitoring
- System Wake-Up Switch
- Embedded Applications

PERFORMANCE SPECIFICATIONS

All values are typical at +24°C, 80Hz and 3.3Vdc excitation unless otherwise stated. Measurement Specialties reserves the right to update and change these specifications without notice.

Parameters

DYNAMIC

	±25	±50	±100	±200	±500	Notes
Range (g)	±25	±50	±100	±200	±500	
Sensitivity (mV/g)	50.0	25.0	12.5	6.25	2.5	±30%
Frequency Response (Hz) ¹	2-2000	2-2000	2-2000	2-2000	2-2000	±2dB
Natural Frequency (Hz)	>10000	>10000	>10000	>10000	>10000	
Non-Linearity (%FSO)	±2	±2	±2	±2	±2	
Transverse Sensitivity (%)	<10	<10	<10	<10	<10	
Shock Limit (g)	5000	5000	5000	5000	5000	

ELECTRICAL

	Exc Voltage / 2	Exc Voltage / 2	Exc Voltage / 2	Exc Voltage / 2	Exc Voltage / 2	
Bias Voltage (Vdc)	Exc Voltage / 2	Exc Voltage / 2	Exc Voltage / 2	Exc Voltage / 2	Exc Voltage / 2	
Total Supply Current (µA)	<4	<4	<4	<4	<4	
Excitation Voltage (Vdc) ³	3.3 to 5.5	3.3 to 5.5	3.3 to 5.5	3.3 to 5.5	3.3 to 5.5	
Output Impedance (Ω)	<100	<100	<100	<100	<100	
Insulation Resistance (MΩ)	>100	>100	>100	>100	>100	@100Vdc
Broadband Noise (µV)	300	210	160	150	160	2Hz-10kHz
Spectral Noise (µg/√Hz)	120	120	120	120	400	@ 10Hz
Spectral Noise (µg/√Hz)	80	80	80	80	320	@ 100Hz
Spectral Noise (µg/√Hz)	40	40	40	40	160	@ 1000Hz
Warm-Up Time (msec)	30					
Shielding	100%					
Ground Isolation	Isolated from Mounting Surface					

ENVIRONMENTAL

Temperature Response (%)	-10/+20 from -20°C to +80°C
Operating Temperature (°C)	-20 to +80
Storage Temperature (°C)	-20 to +80

PHYSICAL

Sensing Element	Ceramic (shear mode)
Case Material	Ceramic Base, Nickel Silver Cover
Weight (grams)	3.6

¹ A wider frequency response of 2-6000Hz is available on model 832M1

² The model 832 is not to be reflow soldered at high temperature, manual soldering is recommended. See application note.

³ The model 832 can be operated with 2.8V excitation but the full-scale range will be limited.

Calibration supplied: CS-SENS-0100 NIST Traceable Amplitude Calibration at 80Hz

The information in this sheet has been carefully reviewed and is believed to be accurate; however, no responsibility is assumed for inaccuracies. Furthermore, this information does not convey to the purchaser of such devices any license under the patent rights to the manufacturer. Measurement Specialties, Inc. reserves the right to make changes without further notice to any product herein. Measurement Specialties, Inc. makes no warranty, representation or guarantee regarding the suitability of its product for any particular purpose, nor does Measurement Specialties, Inc. assume any liability arising out of the application or use of any product or circuit and specifically disclaims any and all liability, including without limitation consequential or incidental damages. Typical parameters can and do vary in different applications. All operating parameters must be validated for each customer application by customer's technical experts. Measurement Specialties, Inc. does not convey any license under its patent rights nor the rights of others.

ORDERING INFORMATION

PART NUMBERING Model Number+Range

832-GGGG
|
| _____ Range (0200 is 200g)

Example: 832-0200
 Model 832, 200g

TE.com/sensorsolutions

Measurement Specialties, Inc., a TE Connectivity company.

Measurement Specialties, TE Connectivity, TE Connectivity (logo) and EVERY CONNECTION COUNTS are trademarks. All other logos, products and/or company names referred to herein might be trademarks of their respective owners.

The information given herein, including drawings, illustrations and schematics which are intended for illustration purposes only, is believed to be reliable. However, TE Connectivity makes no warranties as to its accuracy or completeness and disclaims any liability in connection with its use. TE Connectivity's obligations shall only be as set forth in TE Connectivity's Standard Terms and Conditions of Sale for this product and in no case will TE Connectivity be liable for any incidental, indirect or consequential damages arising out of the sale, resale, use or misuse of the product. Users of TE Connectivity products should make their own evaluation to determine the suitability of each such product for the specific application.

© 2015 TE Connectivity Ltd. family of companies All Rights Reserved.