

# MHR0500 Series - Magnetic-Hall rotary position sensor (miniature)

High performance series

## Dimensions for MHR0510 - Flange mounting

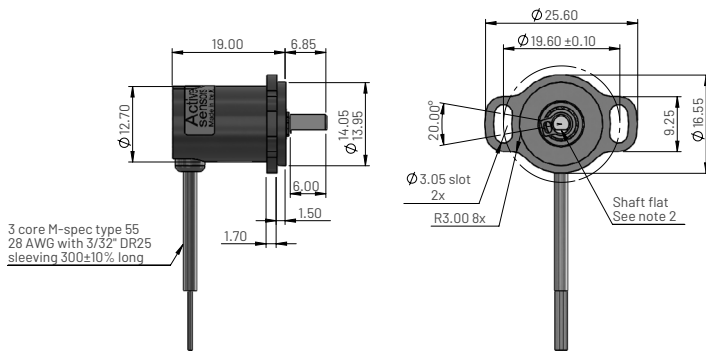

## Dimensions for MHR0520 - Synchro mounting

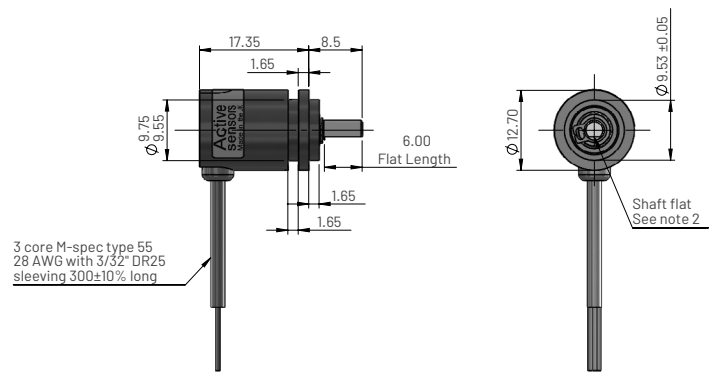

## Ordering information

MHR0510 XV-XXX

Output direction (viewed on shaft)

- C = Clockwise
- A = Anticlockwise

Electrical angle in degrees

## Ordering information

MHR0520 XV-XXX

Output direction (viewed on shaft)

- C = Clockwise
- A = Anticlockwise

Electrical angle in degrees

## Electrical and mechanical specification for MHR0500

Parameters	Values	Units
Input specification		
Supply voltage (Vs)	5.0±10% regulated	VDC
Over voltage protection	Up to +20	VDC
Supply current	<15	mA
Reverse polarity protection	Up to -10	VDC
Power on settlement time	<100	ms
Input voltage rise time	0.25 minimum	V/ms
Output specification		
Output type	Analogue voltage	
Output direction	Clockwise or anticlockwise (specified at time of order)	
Voltage output (Vout)	0-Vs (+5)	VDC
Monotonic range (Note 4)	Linear range	
Load resistance	>10K	Ohms
Output noise	<5	mV RMS
Performance specification		
Measurement range	20 to 360±2 in 1° increments	°
Resolution	0.025	% of measurement range
Non-linearity (Note 4)	<±0.025	%FS
Temperature coefficient (Vout)	<±0.003	%FS/°C
Update rate	500 Nom	Hz
Max operating speed	600	RPM
General specification		
Weight (approx.)	22	grams
Protection/sealing	IP68 and IP69K	
Life (shaft in bush bearing)	500 million cycles	dependent on environment
Dither life	Contactless - no degradation due to shaft dither	
Operational temperature	-40 to +150	°C
Storage temperature	-55 to +150	°C
Materials	Sensor	Case - Glass filled polymer, Shaft - Stainless steel
	Top cap	GR polymer

## Notes

1. Incorrect wiring may cause internal damage.
2. When shaft marking is facing cable exit, instrument is mid-travel (2.5V output).
3. Non-linearity is calculated from least squares best fit method.
4. Linear Range = Measurement range x 0.995 Nom.
5. Due to hall effect technology used in this device, ferrous materials and magnetic fields close to the sensor may influence output.
6. General dimension tolerance is  $\pm 0.25$

## Electrical connections (see note 1)

Wire Colour	Function
Red	Supply Voltage (Vs)
White	Output Voltage (Vout)
Black	Ground

## Typical output

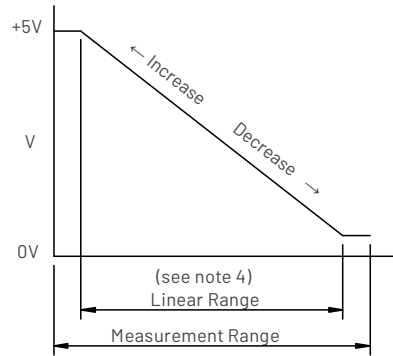

## Shaft and flat detail

