

Dimensions for MHR5210 - Flange mounting with a sprung shaft

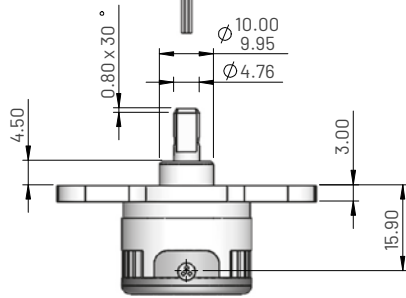

Driving side detail

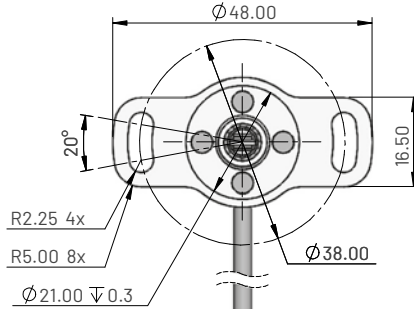
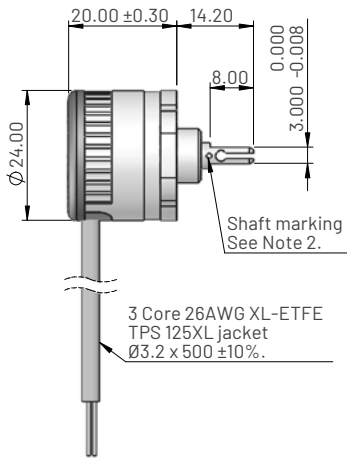
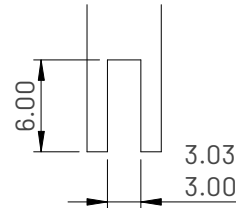

Ordering information

MHR5210 XV-XXX

Output direction (viewed on shaft)

- C = Clockwise
- A = Anticlockwise

Electrical angle in degrees

Dimensions for MHR5220 - Flange mounting with a round shaft

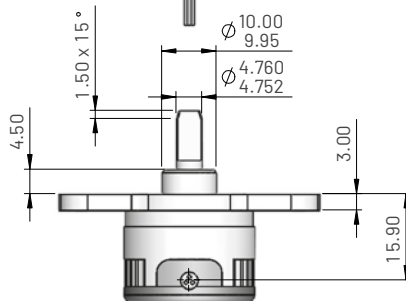
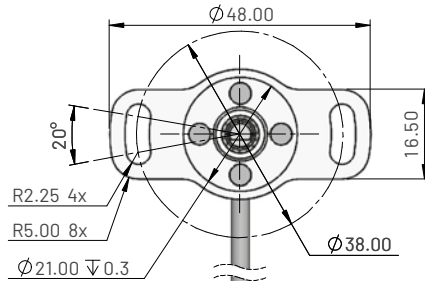
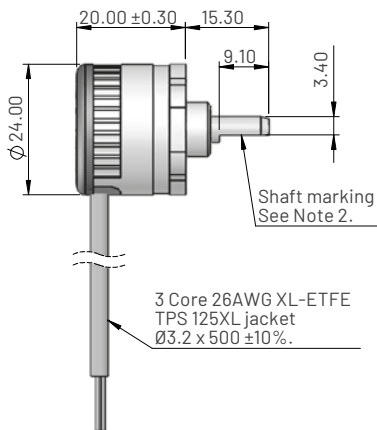

Ordering information

MHR5220 XV-XXX

Output direction (viewed on shaft)

- C = Clockwise
- A = Anticlockwise

Electrical angle in degrees

Dimensions for MHR5230 - Flange mounting with a blade shaft

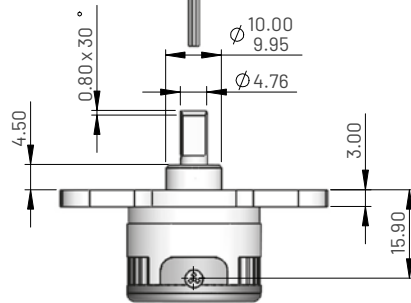
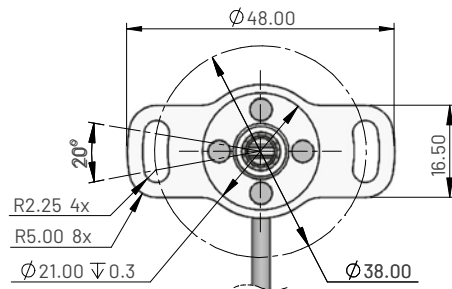
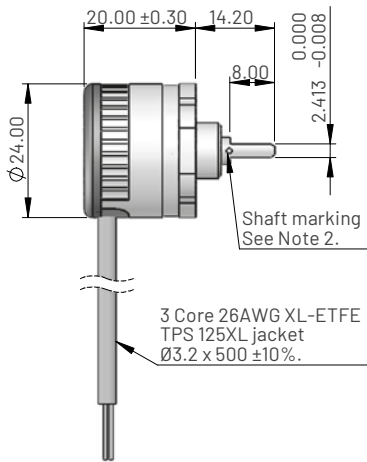

Driving side detail

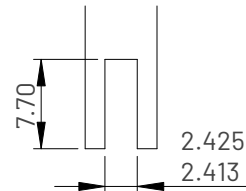

Ordering information

MHR5230 XV-XXX

Output direction (viewed on shaft)

C = Clockwise

A = Anticlockwise

Electrical angle in degrees

Electrical and mechanical specification for MHR5200

Input specification

Supply voltage (Vs)	5.0±10% regulated	8 to 30 unregulated	VDC
Over voltage protection	Up to 50		VDC
Supply current	<15		mA
Reverse polarity protection	Up to -10		VDC
Power on settlement time	<100		ms
Input voltage rise time	0.25 minimum		V/ms

Output specification

Output type	Analogue voltage		
Output direction	Clockwise or anticlockwise (specified at time of order)		
Voltage output (Vout)	0-Vs (+5)	0 - 5.0	VDC
Monotonic range	Ratiometric with Vs	<0.01% FS	
	Linear Range (see note 5)		
Load resistance	>10K		Ohms
Output noise	<5		mV RMS

Performance specification

Measurement range	20 to 360±2 in 1° increments		°
Resolution	0.025		% of measurement range
Non-linearity (Note 4)	<±0.25		%FS
Temperature coefficient (Vout)	<±0.003	<±0.011	%FS/°C
Update rate	500 Nom		Hz
Max operating speed	600		RPM

General specification

Weight (approx.)	30		grams
Protection/sealing	Electronic housing IP68 and IP69K		
Life (shaft in bush bearing)	>500 million cycles		dependant on environment
Dither life	Contactless - no degradation due to shaft dither		
Operational temperature	-40 to +150	See de-rating graph	°C
Storage temperature	-55 to +150		°C
Materials	Case: Glass filled polymer, Top cap: GF polymer, Shaft: Stainless steel 316		

Notes

1. Incorrect wiring may cause internal damage.
2. When shaft marking is facing cable exit, instrument is mid-travel (2.5V output).
3. Do not operate between 5.5V and 8V.
4. Non-linearity is calculated from least squares best fit method over the Linear Range.
5. Linear Range = Measurement range x 0.995 Nom.
6. Due to hall effect technology used in this device, ferrous materials and magnetic fields close to the sensor may influence output.
7. General dimension tolerance is ±0.25.

Electrical connections (see note 1)

Wire Colour	Function
Red	Supply Voltage (Vs)
White	Output Voltage (Vout)
Black	Ground

Typical output

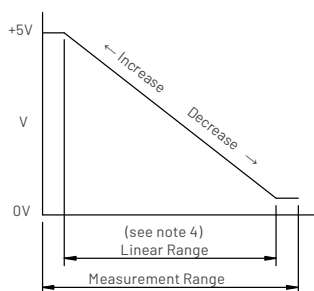

Input voltage de-rating graph

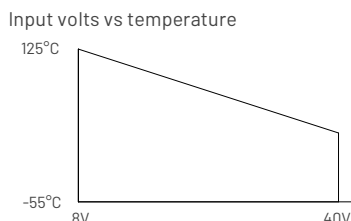

Accessories

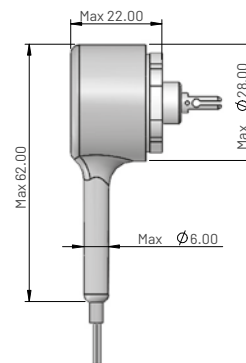

Boot
Part No: JN025-002

Material
Polyolefin

Boot dimensions when fitted (Boot supplied separately)