

## Features:

- Accurate DC measurement
- Voltage Output
- High shock protection
- Low noise – high resolution
- Differential-ended output signal
- Gas damping
- Low cost sensors



## Applications:

- Structural monitoring and testing
- Aerospace vibration testing
- Automotive ride quality & comfort
- Railway engineering
- GVT and flutter testing

Capacitive accelerometers are based on proven micro-electro-mechanical systems (MEMS) technology. These capacitive accelerometers are reliable and long-term stable. They have DC response. The advantage of these sensors is their outstanding temperature stability, their lightweight and they are low cost sensors. These sensors have reliable aluminum housing with IP68 protection class.

Dynalabs 1000DE series accelerometers provide an outstanding noise performance from 25 to 170  $\mu\text{g}/\sqrt{\text{Hz}}$ . These accelerometers provide a wide frequency range ( $\pm 3\text{dB}$ ) from 1,500 Hz to 3,000 Hz.

## Specifications:

		1002DE	1004DE	1008DE	1010DE	1020DE	1040DE	1050DE	1100DE	1200DE	1500DE
Full-scale acceleration	(g)	$\pm 2$	$\pm 4$	$\pm 8$	$\pm 10$	$\pm 20$	$\pm 40$	$\pm 50$	$\pm 100$	$\pm 200$	$\pm 500$
Frequency range ( $\pm 3\text{dB}$ )	(Hz)	1,500	1,500	1,500	1,500	1,500	1,500	3,000	3,000	3,000	3,000
Non-linearity (full scale)	(%)	0.1	0.1	0.1	0.1	0.1	0.1	0.1	0.1	0.1	0.1
Noise (in band)	( $\mu\text{g}/\sqrt{\text{Hz}}$ )	25	25	25	80	75	110	35	50	80	170
Scale factor (nominal)	(mV/g)	1,600	800	400	320	160	80	80	40	20	8
Shock survivability	(g)	5,000	5,000	5,000	5,000	5,000	5,000	6,000	6,000	6,000	6,000

## Physical and Environmental:

Protection Level	IP 68
Operating Voltage	6 V – 40 V
Operating Temperature	-40 °C to +100 °C
Weight (without cable)	25 g (aluminum) 55 g (steel)
Housing Material	Aluminum or Steel
Connector (Optional)	D-Sub 9 or 15 pin, Lemo, Binder
Mounting	Adhesive or screw mount
Base plate (Optional)	Aluminum or Steel

## Technical Drawings:

± 2g to ± 40g:

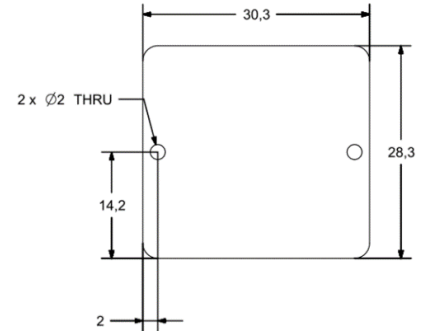
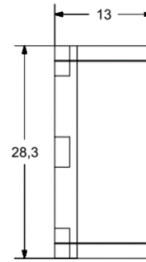
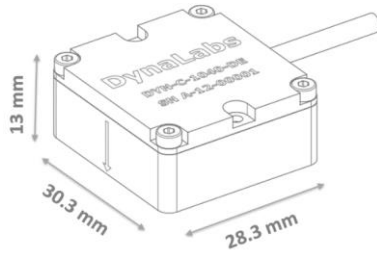

± 50g to ± 500g:

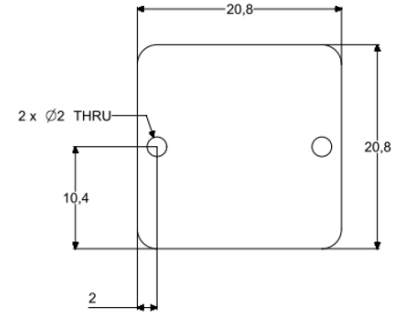
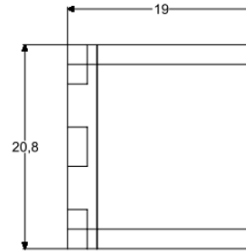
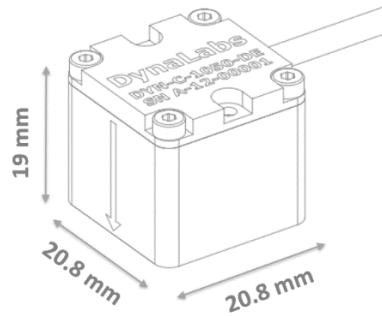

## Options:

- Custom Cable Length (5m standard cable)
- Custom Housing Material
- Custom Connector
- Base plate

Standard length of the integrated cable is 5 meters. But, based on request customized cable lengths are possible.

Standard version has no connector at the cable end. However, it is possible to assemble connector during production.

## Cable Code/Pin Configuration:

- |                  |             |  |
|------------------|-------------|--|
| • Red            | : V+        | Supply voltage   |
| • Black          | : Ground    | GND  |
| • X-Axis: Yellow | : Signal(+) | Positive, analog output voltage signal for differential mode |
| Blue             | : Signal(-) | Negative, analog output voltage signal for differential mode |

**Cable:** 4x #28 AWG Conductors PFA Insulated, Braided Shield, TPE Jacket

## Quality:

All Dynalabs products are **CE** compliant.