

Features:

- Accurate DC measurement
- Voltage Output
- High frequency response
- High shock protection
- Low noise – high resolution
- Single-ended output signal
- Gas damping
- Low cost sensors



Applications:

- Structural monitoring and testing
- Aerospace vibration testing
- Automotive ride quality & comfort
- Railway engineering
- GVT and flutter testing

Capacitive accelerometers are based on proven micro-electro-mechanical systems (MEMS) technology. These capacitive accelerometers are reliable and long-term stable. They have DC response. The advantage of these sensors is their outstanding temperature stability, low noise-high resolution features and their low cost. These sensors have reliable aluminum housing with IP68 protection class.

Dynalabs 3000SE series triaxial accelerometers provide an outstanding noise performance from 25 to 1,200 $\mu\text{g}/\sqrt{\text{Hz}}$. These accelerometers provide a wide frequency range ($\pm 3\text{dB}$) from 1,500 to 3,000 Hz.

Specifications:

		3002SE	3004SE	3008SE	3010SE	3020SE	3040SE	3050SE	3100SE	3200SE	3500SE
Full-scale acceleration	(g)	± 2	± 4	± 8	± 10	± 20	± 40	± 50	± 100	± 200	± 500
Frequency range ($\pm 3\text{dB}$)	(Hz)	1,500	1,500	1,500	1,500	1,500	1,500	3,000	3,000	3,000	3,000
Non-linearity (full scale)	(%)	0.1	0.1	0.1	0.1	0.1	0.1	0.1	0.1	0.1	0.1
Noise (in band)	($\mu\text{g}/\sqrt{\text{Hz}}$)	25	25	25	80	80	110	130	220	550	1,200
Scale factor (nominal)	(mV/g)	400	200	100	80	40	20	40	20	10	4
Shock survivability	(g)	5,000	5,000	5,000	5,000	5,000	5,000	6,000	6,000	6,000	6,000

Physical and Environmental:

Protection Level	IP 68
Operating Voltage	6 V – 40 V ($\pm 2\text{g}$ to $\pm 40\text{g}$) 6 V – 35 V ($\pm 50\text{g}$ to $\pm 500\text{g}$)
Operating Temperature	-40 °C to +100 °C
Weight (without cable)	20 g (aluminum) 40 g (steel)
Housing Material	Aluminum or Steel
Connector (Optional)	D-Sub 9 or 15 pin, Lemo, Binder
Mounting	Adhesive or screw mount
Base plate (Optional)	Aluminum or Steel

Technical Drawings:

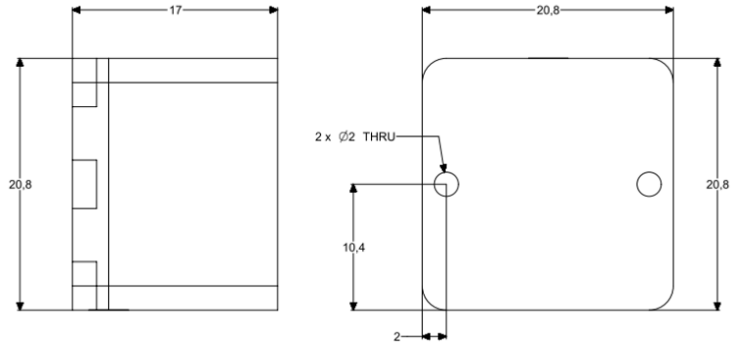
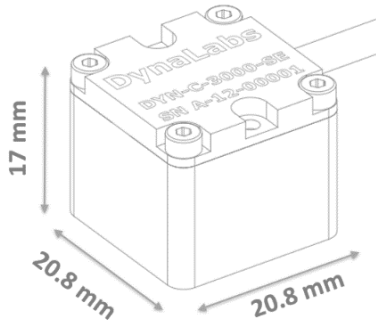

Options:

- Custom Cable Length (5m standard cable)
- Custom Housing Material
- Custom Connector
- Base plate

Standard length of the integrated cable is 5 meters. But, based on request customized cable lengths are possible.

Standard version has no connector at the cable end. However, it is possible to assemble connector during production.

Cable Code/Pin Configuration:

- | | | |
|------------------|----------|---|
| • Red | : V + | Supply voltage |
| • Black | : Ground | Power GND |
| • X-Axis: Yellow | : Signal | Analog output voltage signal for single ended |
| • Y-Axis: Blue | : Signal | Analog output voltage signal for single ended |
| • Z-Axis: White | : Signal | Analog output voltage signal for single ended |

Cable: 5x #28 AWG Conductors PFA Insulated, Braided Shield, TPE Jacket

Quality:

All Dynalabs products are **CE** compliant.