

DYNALABS INERTIAL SHAKER(DYN-IS-40)

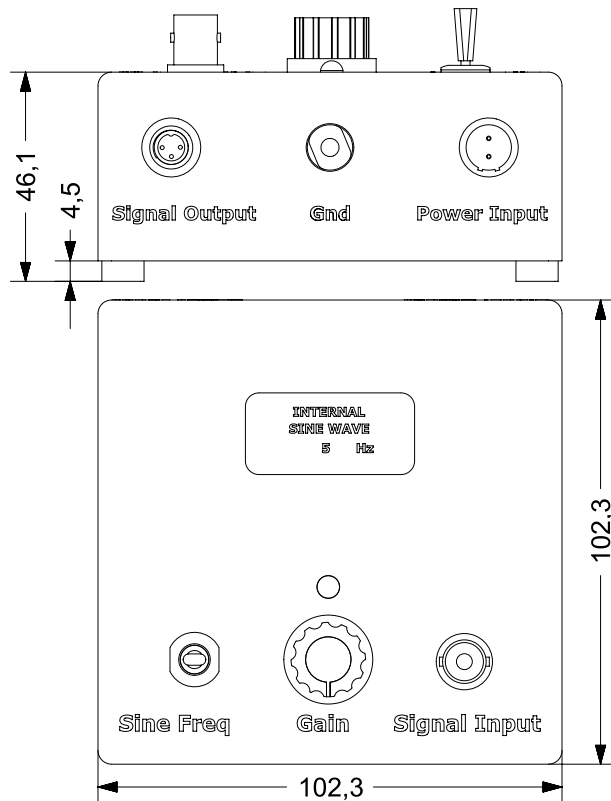

$\varnothing 3^{+0,1}_0$ THRU (MOUNTING INTERFACE WITH M3X60 STAINLESS BOLT)

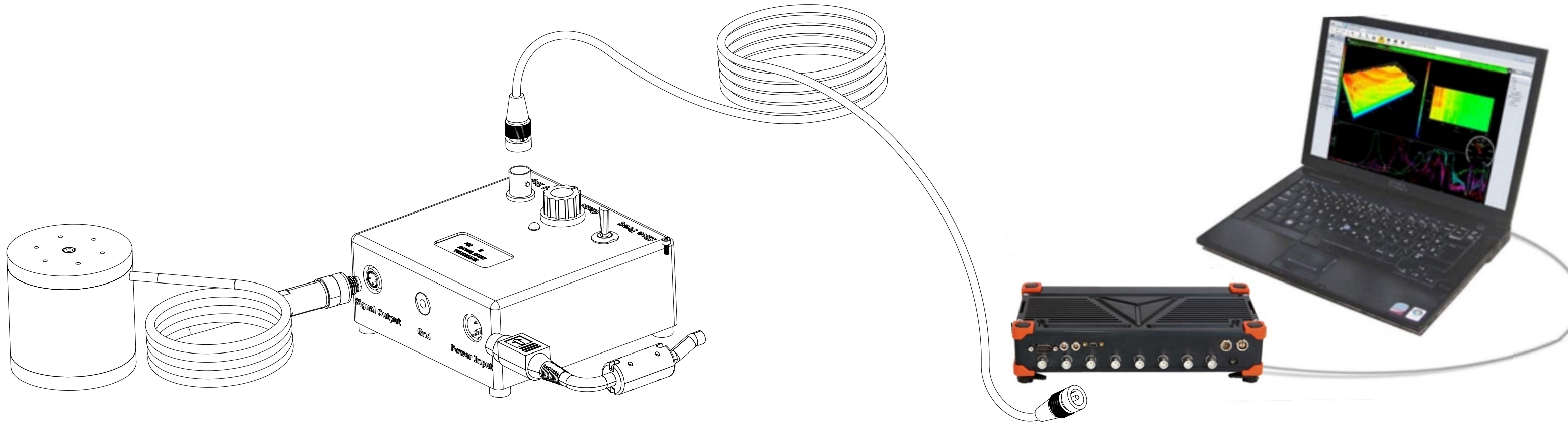
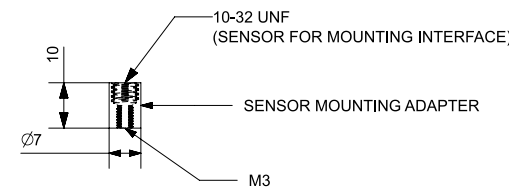

SECTION A-A

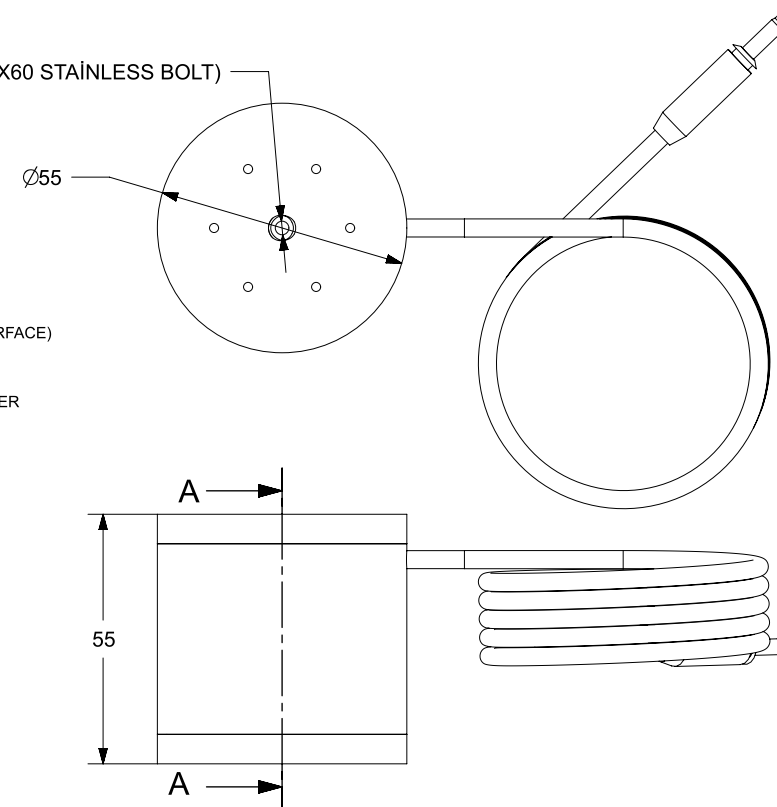

Output Force	40 N
Frequency Range	10-3000 Hz
Displacement(Peak to Peak)	8 mm
Moving Mass	0.16 kg
Shaker Weight	0.5 kg
Cooling System	Natural Convection
Operating Temperature Range	5-35 °C
Suspension	Spring
Maximum Input Current	4A (RMS)
AMPLIFIER	EXTERNAL
Amplifier Weight	0.65 kg
Power Supply Voltage	24V DC
Power Supply Current	5 A
External Signal Voltage Level	1 VAC(PEAK)

System Components :Electrodynamic Shaker (Integrated Cable(5meter)) + Amplifier(DYN-SA-150)+Signal Cable(BNC-BNC)(5 meter)+Amplifier Power Adapter+ M3X60 Stainless Bolt+Sensor Mounting Adapter+User Manual+Ground Cable

All dimensions in mm

All rights reserved. Reproduction or issue to third parties in any form whatsoever is not permitted without written authority from the proprietors. This document is subject to change without notice, and should not be construed as a commitment or representation by Dynalabs Ltd.

