

DYNALABS MODAL SHAKER(DYN-MS-100)

Output Force(Sinus)	100 N
Frequency Range	0-7.5 kHz
Displacement(P-P)	10 mm
Maximum Acceleration	60 g
Shaker Weight	7.2 kg
Cooling System	Natural Convection
Operating Temperature Range	5-35 °C
Suspension	Carbon Fiber
Maximum Input Current	6A (RMS)
AMPLIFIER	INTERNAL
Power Supply Voltage	24V DC
Power Supply Current	5 A
External Signal Voltage Level	1 VAC(PEAK)

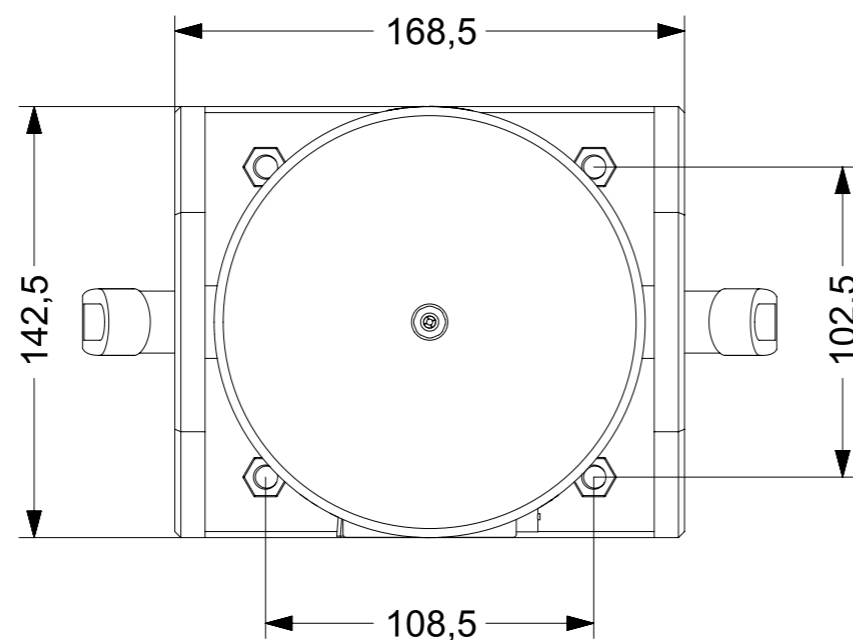

Stinger Set

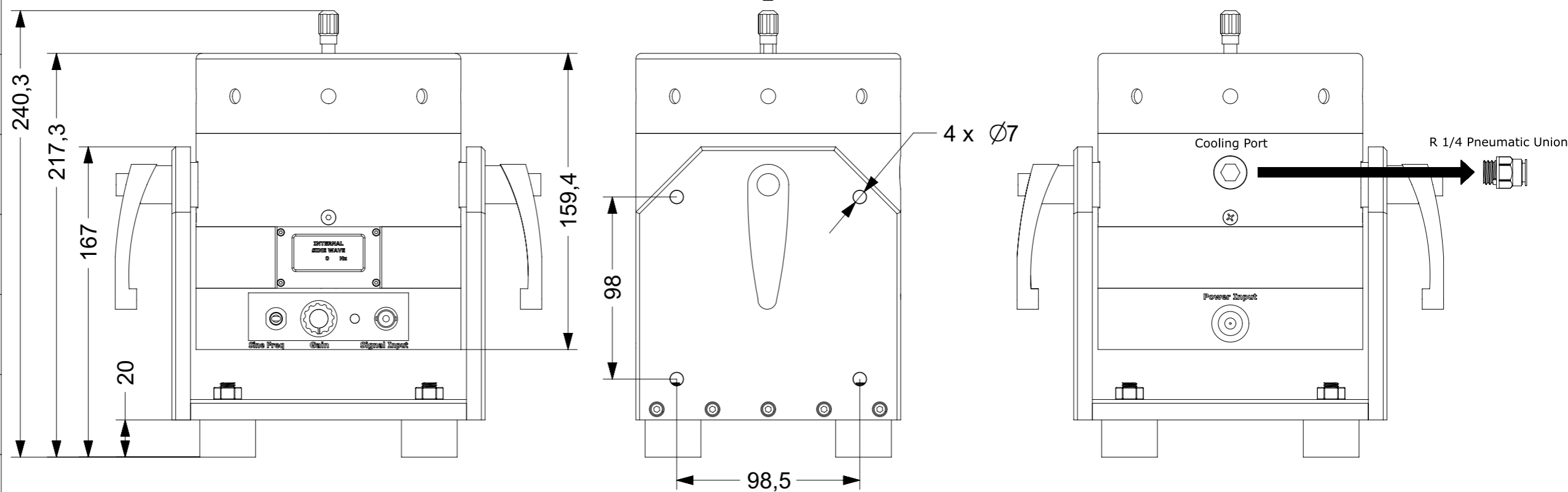
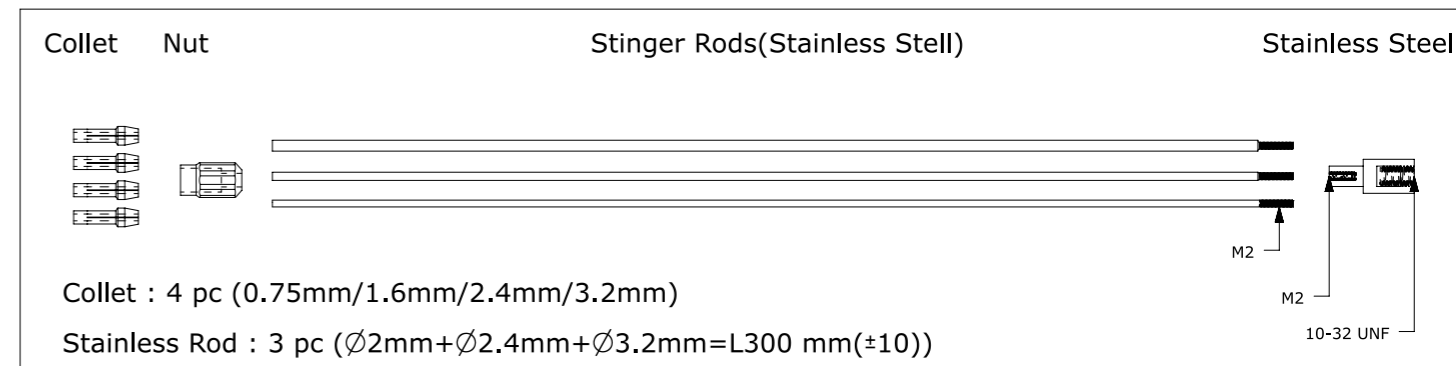

System Components : Electrodynamic Shaker +Power Adapter + Signal Cable(BNC-BNC) + R 1/4 Pneumatic Union + M6X10 Stainless Bolt + User Manual

All dimensions in mm

All rights reserved. Reproduction or issue to third parties in any form whatsoever is not permitted without written authority from the proprietors. This document is subject to change without notice, and should not be construed as a commitment or representation by Dynalabs Ltd.

