

### Extraneous Load Factors

**Equation:**  $\sigma_{max} \geq (A)Fx + (B)Fy + (C)Fz + (D)Mx + (E)My + (F)Mz$

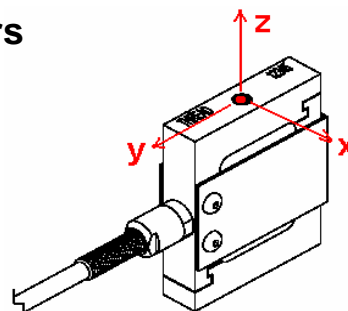

**Material:** Aluminum 2024-T4 (\*AL)

Model #	Capacity (lb)	A	B	C	D	E	F
LSB300 (*AL)	25	215.70	342.93	467.39	518.94	526.17	298.97
	50	270.92	211.99	288.90	190.70	180.55	158.50
	100	221.26	207.51	155.33	192.98	182.87	130.86
	200	219.48	199.92	90.86	207.87	190.33	119.44
	300	230.18	203.63	97.29	298.52	186.14	116.72

$\sigma_{max}$  Table

Material	Static Load (=60% Y.S.)	Fatigue (Non Reversing Loads)	Fatigue (Full Reversing Loads)
2024-T4/T351	28,000	18,000	15,000

\*Value is 75% of Fatigue Strength based on 10-20 x 10<sup>6</sup> cycles and allow for factors that influence Fatigue such as surface finish, stress concentrations, corrosion, temperature and other variables for the production of the transducer, for infinite Fatigue Life (100 x 10<sup>6</sup>) use 75% of values shown.

### Deflection & Natural Frequency

Model #	Capacity (lb)	Deflection (in.)	Natural Frequency (Hz)	$\beta$
LSB300 (*AL)	25 (*AL)	0.004	750	0.1100
	50 (*AL)	0.007	800	0.1100
	100 (*AL)	0.008	1,100	0.1100
	200 (*AL)	0.01	1,300	0.1100
	300 (*AL)	0.01	1,600	0.1100

### Natural Frequency & Frequency Response Equation's:

$$\text{Natural Frequency (FN)} = 3.13 \sqrt{\frac{1}{\frac{\beta}{\text{Capacity}} \cdot \text{Deflection}}} \text{ (Hz)}$$

$$\text{Frequency Response with load (FR)} = 3.13 \sqrt{\frac{1}{\frac{\beta + \text{AppliedLoad}}{\text{Capacity}} \cdot \text{Deflection}}} \text{ (Hz)}$$

This documentation was generated and completed to the best ability of FUTEK's Engineering Team using FEA Analysis, Empirical data and Multiple Testing Simulations. The information and recommendations on this document are presented in good faith and believed to be correct however, FUTEK Advanced Sensor Technology makes no representations or warranties as to the completeness accuracy of the information.

\*Where  $\beta$  values are obtained by Futek Engineers

---

This documentation was generated and completed to the best ability of FUTEK's Engineering Team using FEA Analysis, Empirical data and Multiple Testing Simulations. The information and recommendations on this document are presented in good faith and believed to be correct however, FUTEK Advanced Sensor Technology makes no representations or warranties as to the completeness or accuracy of the information.