

FEATURES

- Various capacities and inner diameters.
- Compact size, ideal for tight spaces.
- Quick response with low deflection.
- Robust cable strain relief.
- Low power consumption.

- Non-loading surface, do not contact
- Active End
- Fixed End

+ Output (compression)

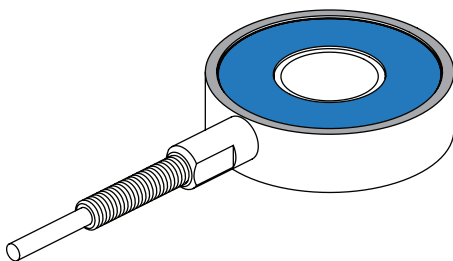
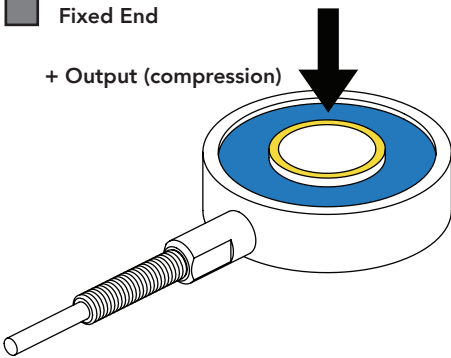

SPECIFICATIONS

PERFORMANCE

Nonlinearity	±0.5% of RO
Hysteresis	±0.5% of RO
Nonrepeatability	±0.5% of RO

ELECTRICAL

Rated Output (RO)	2 mV/V nom
Excitation (VDC or VAC)	18 max
Bridge Resistance	700 Ohm nom
Insulation Resistance	≥500 MOhm @ 50 VDC
Connection	#29 AWG, 4 conductor, spiral shielded Teflon cable, 10 ft [3 m] long
Wiring/Connector Code	WC1

MECHANICAL

Capacities	50 lb [222 N], 100 lb* [445 N]*, 250 lb [1112 N], 500 lb* [2224 N]*, 1000 lb* [4448 N]*
Weight (approximate)	2 oz [57 g]
Safe Overload	150% of RO
Deflection	0.001 in [0.025 mm] nom
Material	17-4 PH stainless-steel
IP Rating	IP64

TEMPERATURE

Operating Temperature	-60 to 200°F (-50 to 93°C)
Compensated Temperature	60 to 160°F (15 to 72°C)
Temperature Shift Zero	±0.005% of RO/°F (0.01% of RO/°C)
Temperature Shift Span	±0.005% of Load/°F (0.01% of Load/°C)

CALIBRATION

Calibration Test Excitation	10 VDC
Calibration (standard)	5-pt Compression
Shunt Calibration Value	100 kOhm

CONFORMITY

RoHS	EU 2015/863
CE	EN55011; EN61326-1

*Commonly stocked capacities

DIMENSIONS inches [mm]

TOLERANCE:
 .X ± 0.1" [2.5]
 .XX ± 0.01" [0.25]
 .XXX ± 0.005" [0.127]

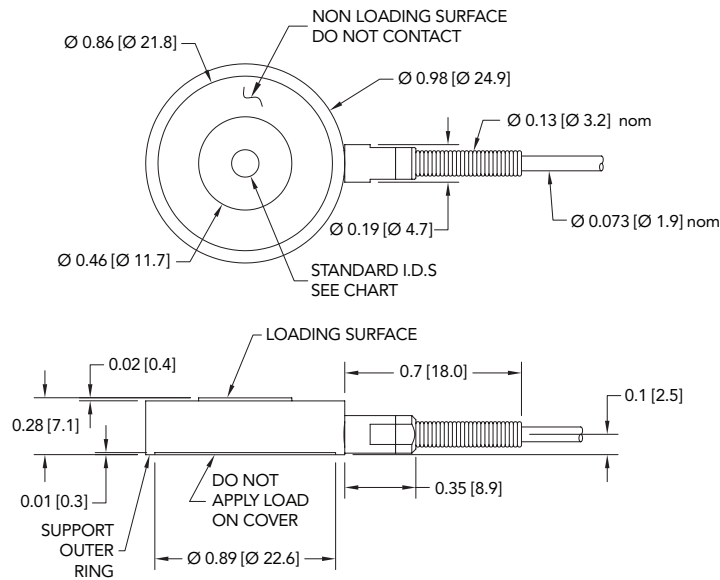

WIRING CODE (WC1 WITH SHIELD)

RED	+ EXCITATION
BLACK	- EXCITATION
GREEN	+ SIGNAL
WHITE	- SIGNAL
SHIELD	FLOATING

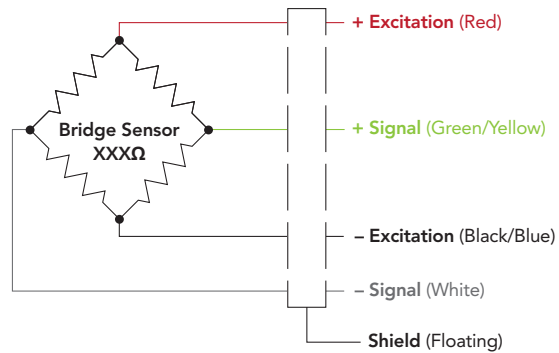

Note: While torquing bolts, high tension forces will occur during installation, which could result in overloading the sensor. FUTEK recommends connecting the sensor to a system in order to monitor the applied forces. FUTEK is not liable or responsible for the mishandling of the sensor during installation.

INNER DIAMETER (Actual)

Nominal ID	Actual Dimension	+0.01 -0.00	+0.25 -0.00
3/16	0.197 [5.01]		
1/4	0.259 [6.58]		
5/16	0.322 [8.18]		
3/8	0.384 [9.75]		

Drawing Number: FI1425-C

FUTEK reserves the right to modify its design and specifications without notice.

The information provided herein was developed using FEA analysis, empirical data and multiple testing simulations. FUTEK presents the information in good faith and believes it is correct but makes no representations or warranties as to the completeness or accuracy of the information provided. User's application may produce different data and/or results. By using this information, you agree that you have read and understand this disclosure. Please contact us to discuss your particular application and needs.