

FUTEK MODEL QLA115

DONUT LOAD CELL (Previously Q07673)

| | | | |
|-------------------|-------------|--------------------|---------|
| INCH (mm) | | R.O.= Rated Output | |
| WIRING CODE (WC1) | | | |
| +Excitation | -Excitation | +Signal | -Signal |
| RED | BLACK | GREEN | WHITE |

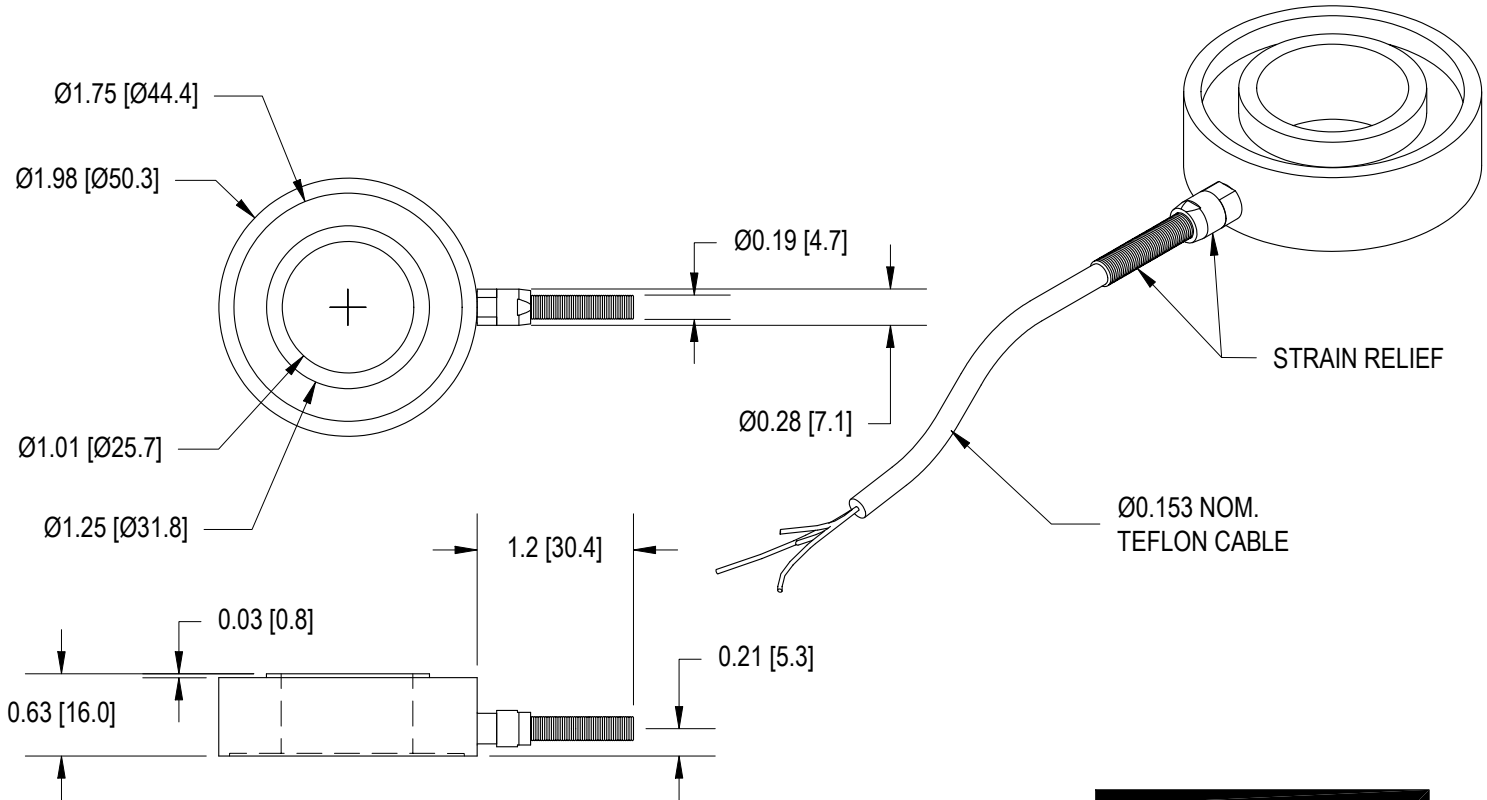

| STK# | CAPACITIES | |
|----------|------------|------|
| | lb | N |
| QSH00045 | 100 | 445 |
| QSH00046 | 1000 | 4448 |

SPECIFICATIONS:

| | |
|---|---------------------------------------|
| RATED OUTPUT | 2 mV/V nom. |
| SAFE OVERLOAD | 150% of R.O. |
| ZERO BALANCE | 1.0% of R.O. |
| EXCITATION (VDC OR VAC) | 10 recommended |
| BRIDGE RESISTANCE | 700 Ω |
| NONLINEARITY | ±1.0% of R.O. |
| HYSTERESIS | ±1.0% of R.O. |
| NONREPEATABILITY | ±0.10% of R.O. |
| TEMP. SHIFT ZERO | 0.005% of R.O./°F (0.009% of R.O./°C) |
| TEMP. SHIFT SPAN | 0.02% of LOAD/°F (0.036% of LOAD/°C) |
| COMPENSATED TEMP. | 60 to 160°F (15 to 72°C) |
| OPERATING TEMP. | -65 to 200°F (-54 to 90°C) |
| MATERIAL | Stainless Steel |
| CABLE: #24 AWG, 4 Conductor Teflon Cable, 5ft Long | |

DSPM Industria*
sensori & trasduttori

Tel +39 02 48 009 757 Fax +39 02 48 002 070

Via Paolo Uccello 4 - 20148 Milano
info@dspmindustria.it www.dspmindustria.it

OLD DWG: F2554-C

OUTLINE DRAWING

STANDARD NOTES: (Unless Otherwise Specified)

- ALL DIMENSIONS ARE IN INCHES
- DRAWING INTERPRETATION DIMS. PER ASME-Y14.5M
- REMOVE BURRS AND BREAK SHARP EDGES .005 - .015
- THREADS PER HANDBOOK H-28
- DIMENSIONS ARE SHOWN AFTER PLATING

ANGLE:
±1/2°

CHAMFER:
±5°

TOLERANCE:
.XX ±.01
.XXX ±.005

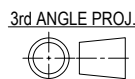

This drawing is submitted solely for the information and exclusive use of the original addressee. It is not to be divulged in whole or in part, by any firm or individual without written permission from:

FUTEK
ADVANCED SENSOR TECHNOLOGY, INC.

MODEL: **QLA115**

DWG No.: **FO1066**

DRAWN BY: **R. WALKER**

CHECKED BY: **R. WALKER**

APPROVED BY: **J. MOKHBERY**

DATE: **Dec. 23, 1998**

MATERIAL:
—

HEAT TREATMENT - FINISH:
—

REVISIONS: (Refer to dwg # revision sheet)