

# FUTEK MODEL QLA254

# CUSTOM DONUT LOAD CELL

STOCK NUMBER: QSH00718

INCH (mm) | R.O.= Rated Output

WIRING CODE (WC1)			
+Excitation	-Excitation	+Signal	-Signal
RED	BLACK	GREEN	WHITE
Shield			
Floating			

**+OUTPUT**  
(COMPRESSION)

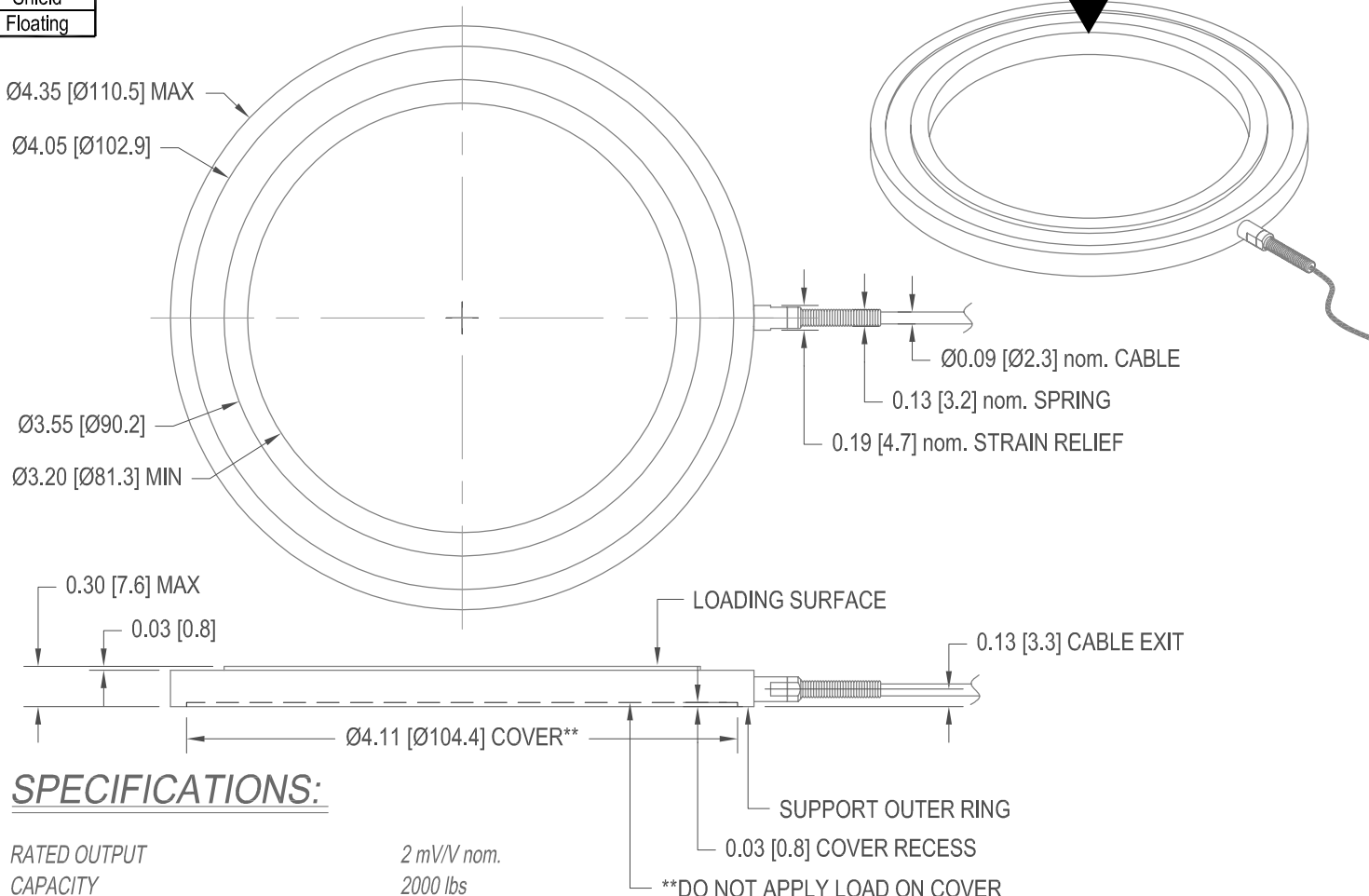

## SPECIFICATIONS:

RATED OUTPUT	2 mV/V nom.
CAPACITY	2000 lbs
SAFE OVERLOAD	150% of R.O.
ZERO BALANCE	±2% of R.O.
EXCITATION	18 VDC MAX
BRIDGE RESISTANCE	350/700 Ω nom.
NONLINEARITY	±2% of R.O.
NONREPEATABILITY	±0.5% of R.O.
TEMP. SHIFT ZERO	±0.02% of R.O./°F
TEMP. SHIFT SPAN	±0.02% of LOAD/°F
COMPENSATED TEMP.	60 to 160°F
OPERATING TEMP.	0 to 200°F
WEIGHT	0.5 lbs
MATERIAL	STAINLESS STEEL
CABLE: #29 Awg 4 Conductor Spiral Shielded Teflon Cable, 10 ft Long	

**DSPM Industria**  
sensori & trasduttori

Via Paolo Uccello 4 - 20148 Milano

Tel +39 02 48 009 757 Fax +39 02 48 002 070 info@dspmindustria.it www.dspmindustria.it

MATERIAL:

—

HEAT TREATMENT - FINISH:

—

REVISIONS: (Refer to dwg # revision sheet)

△ -

## OUTLINE DRAWING

STANDARD NOTES: (Unless Otherwise Specified)

- ALL DIMENSIONS ARE IN INCHES
- DRAWING INTERPRETATION DIMS. PER ASME-Y14.5M
- REMOVE BURRS AND BREAK SHARP EDGES .005 - .015
- THREADS PER HANDBOOK H-28
- DIMENSIONS ARE SHOWN AFTER PLATING

3rd ANGLE PROJ.

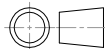

ANGLE:  
±1/2°

CHAMFER:  
±5°

TOLERANCE:  
.X ±0.1  
.XX ±0.01  
.XXX ±0.005

This drawing is submitted solely for the information and exclusive use of the original addressee. It is not to be divulged in whole or in part, by any firm or individual without written permission from:

**FUTEK**  
ADVANCED SENSOR TECHNOLOGY, INC.

10 THOMAS  
IRVINE, CA 92618 USA  
Phone: (949) 465-0900  
Fax: (949) 465-0905

**CAGE: 1X8M6**

MODEL: **QLA254**

DWG No.: **FO1122**

DRAWN BY: H. AU

CHECKED BY: J. VARGAS

APPROVED BY: R. WALKER

DATE: **MAR. 03, 2006**