

FUTEK MODEL QLA294

Heavy Duty Wire Rope Test Load Cell

STOCK NUMBER: QSH01017

| | | | |
|-------------------|------------------|--------------------|------------------|
| INCH (mm) | | R.O.= Rated Output | |
| WIRING CODE (CC1) | | | |
| +Excitation | -Excitation | +Signal | -Signal |
| RED PIN 'A' | BLACK PIN 'B' | GREEN PIN 'C' | WHITE PIN 'D' |
| +Sense | -Sense | | |
| ORANGE PIN 'E' | BLUE PIN 'F' | | |

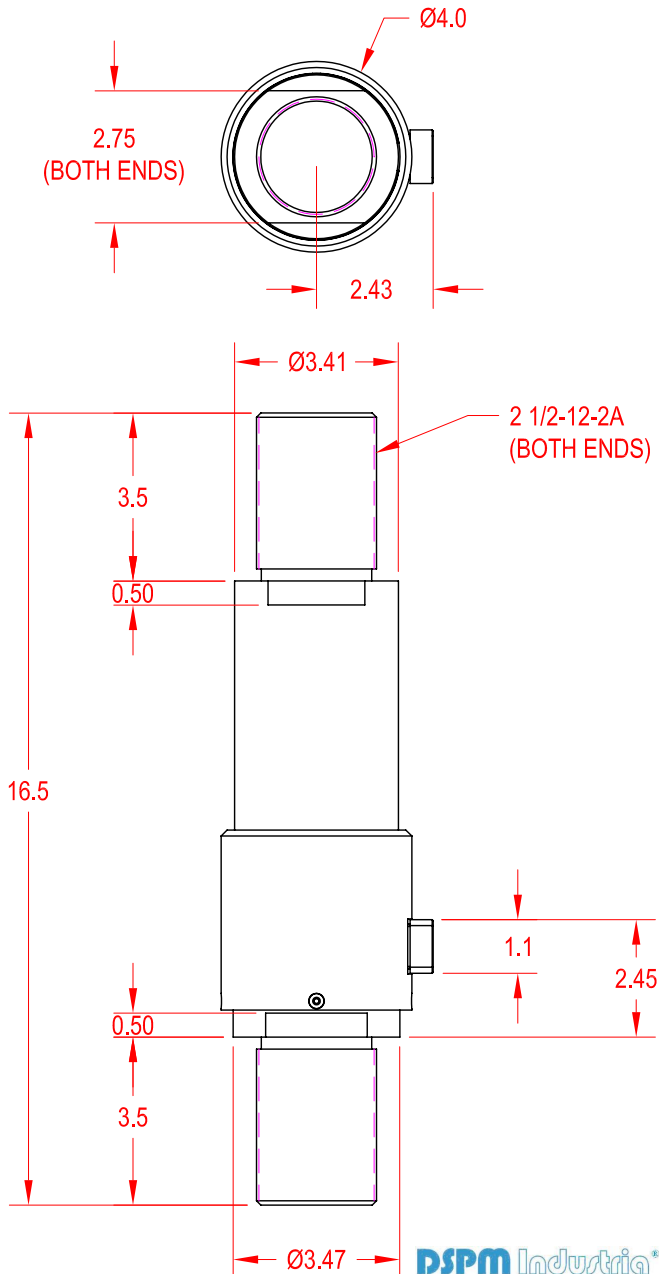

SPECIFICATIONS:

| | |
|-------------------------|---------------------------------------|
| RATED OUTPUT | 2 mV/V nom. |
| CAPACITY | 100000 lbs |
| SAFE OVERLOAD | 150% of R.O. |
| ZERO BALANCE | ±1% of R.O. |
| EXCITATION (VDC OR VAC) | 18 MAX |
| BRIDGE RESISTANCE | 350 / 700 Ω nom |
| NONLINEARITY | ±0.2% of R.O. |
| HYSTERESIS | ±0.2% of R.O. |
| NONREPEATABILITY | ±0.05% of R.O. |
| TEMP. SHIFT ZERO | ±0.01% of R.O./°F |
| TEMP. SHIFT SPAN | ±0.01% of LOAD/°F |
| COMPENSATED TEMP. | 30 to 130°F |
| OPERATING TEMP. | -60 to 200°F |
| WEIGHT | approx 27 lb |
| MATERIAL | Stainless Steel |
| CONNECTOR: | 6 Pin BENDIX Receptacle (PT02A-10-6P) |

DSPM Industria*
sensori & trasduttori

Via Paolo Uccello 4 - 20148 Milano
Tel +39 02 48 009 757 Fax +39 02 48 002 070 info@dspmindustria.it www.dspmindustria.it

MATERIAL:
—

HEAT TREATMENT - FINISH:
—

REVISIONS: (Refer to dwg # revision sheet)

- ▲ 11-06-07
- ▲ 11-27-07
- ▲ 12-28-09

OUTLINE DRAWING

STANDARD NOTES: (Unless Otherwise Specified)

- ALL DIMENSIONS ARE IN INCHES
- DRAWING INTERPRETATION DIMS. PER ASME-Y14.5M
- REMOVE BURRS AND BREAK SHARP EDGES .005 - .015
- THREADS PER HANDBOOK H-28
- DIMENSIONS ARE SHOWN AFTER PLATING

3rd ANGLE PROJ.



ANGLE:
±1/2°

CHAMFER:
±5°

TOLERANCE:
.X ±0.1
.XX ±0.01
.XXX ±0.005

This drawing is submitted solely for the information and exclusive use of the original addressee. It is not to be divulged in whole or in part, by any firm or individual without written permission from:

FUTEK
ADVANCED SENSOR TECHNOLOGY, INC.

CAGE: 1X8M6

MODEL: **QLA294**

DWG No.: **F01195-C**

DRAWN BY: R. WALKER

CHECKED BY: J.V. MEISELBACH

APPROVED BY: —

DATE: **Oct 27, 2007**