

FUTEK MODEL QLA386

CUSTOM TENSION AND COMPRESSION LOAD CELL WITH DIGITAL OUTPUT

ITEM NUMBER: SEE SHEETS

INCH [mm] | R.O.= Rated Output



SENSOR ITEM #: QSH01793

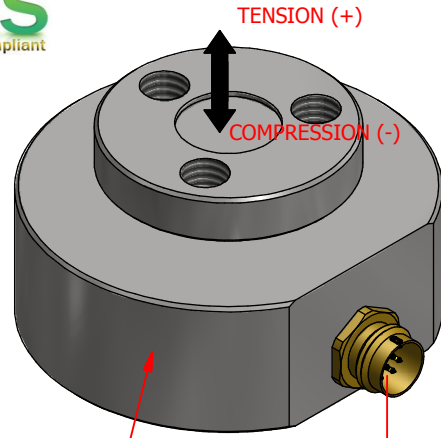
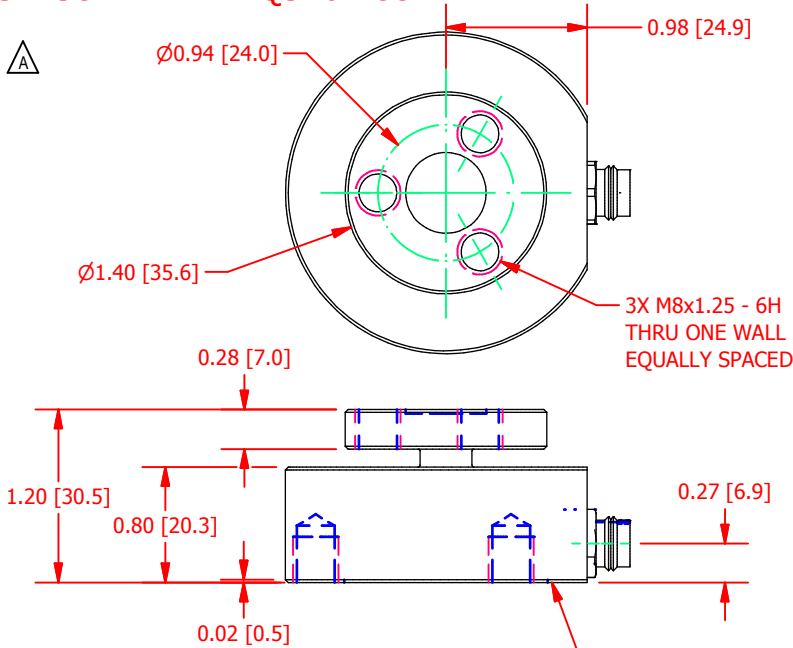

LASER ENGRAVED
 FUTEK LOGO
 ITEM #
 CAPACITY:
 S/N:

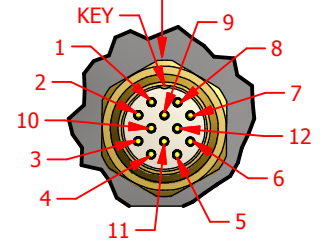

CONNECTOR CODE	
PIN #	DESIGNATION
1	GND
2	+D
3	-D
4	VBUS
5	RST (Internal Use Only)
6	Tx
7	Rx
8	PROG (Internal Use Only)
9	GND
10	N/C
11	N/C
12	N/C

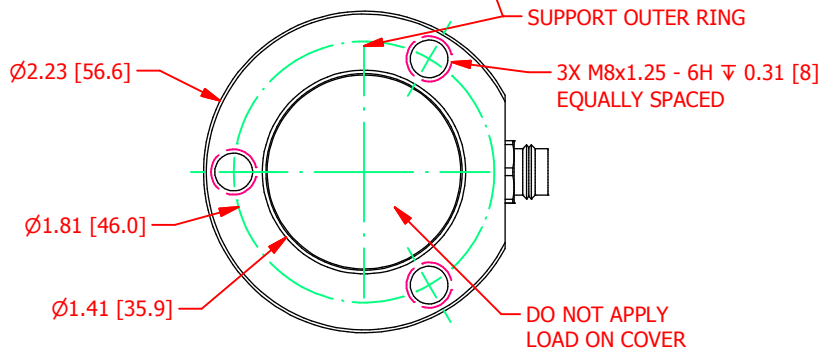

SPECIFICATIONS:

OUTPUT FORMAT	8 CHARACTER ASCII
OUTPUT TYPE	FULL DUPLEX UART (RS232)
BAUD RATE (COMMUNICATION)	57600 BITS/SECOND
CAPACITY	500 lb. [2220N]
ADC SAMPLING RATE	100 SPS
SAFE OVERLOAD	150 % of R.O.
POWER SUPPLY (VDC)	5 V +/- 2% / 1 W
NONLINEARITY	±0.5% of R.O.
HYSTERESIS	±0.5% of R.O.
NONREPEATABILITY	±0.5% of R.O.
COMPENSATED TEMP.	60 to 160 °F (16 to 71 °C)
OPERATING TEMP.	32 to 160 °F (0 to 71 °C)
WEIGHT (approx)	0.9 lb [408.2 g]
MATERIAL	17-4 PH S.S.
DEFLECTION	0.001 [0.0254] nom.
CONNECTOR: MICROCOM CONNECTOR, 12 PIN	
RoHS LEAD FREE	YES
ISO13485 COMPLIANCE	YES
IPC/WHMA-A-620 COMPLIANCE	YES

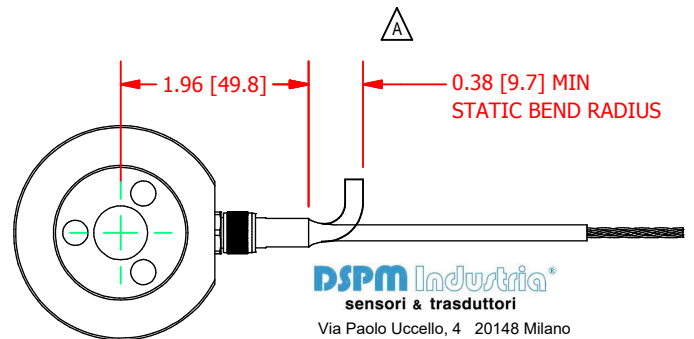

DSPM Industria®
 sensori & trasduttori

Via Paolo Uccello, 4 20148 Milano
 Tel +39 02 48 009 757 Fax +39 02 48 002 070
 info@dspmindustria.it www.dspmindustria.it

CUSTOMER APPROVAL- COMPANY:

OUTLINE DRAWING

This drawing is submitted solely for the information and exclusive use of the original addressee. It is not to be divulged in whole or in part, by any firm or individual without written permission from:



CUSTOMER APPROVAL- NAME / DATE:

STANDARD NOTES: (Unless Otherwise Specified)
 ALL DIMENSIONS ARE IN INCHES
 DRAWING INTERPRETATION DIMS. PER ASME-Y14.5M
 REMOVE BURRS AND BREAK SHARP EDGES .005 - .015
 THREADS PER HANDBOOK H-28
 DIMENSIONS ARE SHOWN AFTER PLATING

ANGLE:
 ± 1/2°

CHAMFER:
 ± 5°

TOLERANCE:
 .X ± 0.1"
 .XX ± 0.01"
 .XXX ± 0.005"



MODEL: **QLA386** DWG No.: **FO1390-A**

DRAWN BY: R. Walker CREATED DATE: 5/4/2015

APPROVED BY: B. FARO MOGHADDAM APPROVED DATE: 5/8/2015

CHECKED BY: CAGE: 1X8M6 SHEET: 1 OF 2

REVISIONS: (Refer to dwg # revision sheet)

A	5-13-15
---	---------

FUTEK MODEL QLA386

CUSTOM TENSION AND COMPRESSION LOAD CELL WITH DIGITAL OUTPUT

ITEM NUMBER: SEE SHEETS

INCH [mm] | R.O.= Rated Output

CABLE ITEM #: QSH01795



CONNECTOR CODE	
PIN #	DESIGNATION
1	GND (BLACK)
4	VBUS (RED)
6	Tx (GREEN)
7	Rx (WHITE)
9	GND (BLUE)
△ SHELL	SHIELD (360 Deg Coverage)
2, 3, 5, 8, 10, 11, 12	N/C

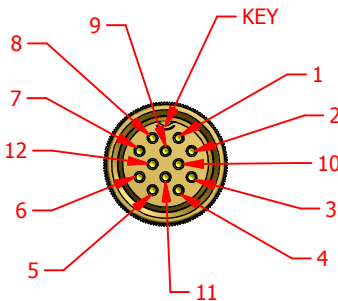

DSPM Industria®
sensori & trasduttori

Via Paolo Uccello 4 - 20148 Milano
Tel +39 02 48 009 757 Fax +39 02 48 002 070
info@dspmindustria.it www.dspmindustria.it

CUSTOMER APPROVAL- COMPANY:

CUSTOMER APPROVAL- NAME / DATE:

REVISIONS: (Refer to dwg # revision sheet)

OUTLINE DRAWING

STANDARD NOTES: (Unless Otherwise Specified)

ALL DIMENSIONS ARE IN INCHES

DRAWING INTERPRETATION DIMS. PER ASME-Y14.5M

REMOVE BURRS AND BREAK SHARP EDGES .005 - .015

THREADS PER HANDBOOK H-28

DIMENSIONS ARE SHOWN AFTER PLATING

ANGLE:
± 1/2°

CHAMFER:
± 5°

TOLERANCE:
.X ± 0.1"
.XX ± 0.01"
.XXX ± 0.005"

3rd ANGLE PROJ.

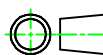

This drawing is submitted solely for the information and exclusive use of the original addressee. It is not to be divulged in whole or in part, by any firm or individual without written permission from:

FUTEK
ADVANCED SENSOR TECHNOLOGY, INC.

MODEL: **QLA386** DWG No.: **FO1390-A**

DRAWN BY: R. Walker CREATED DATE: 5/4/2015

APPROVED BY: B. FARO MOGHADDAM APPROVED DATE: 5/8/2015

CHECKED BY: CAGE: 1X8M6 SHEET: 2 OF 2