

DI SERIES

DISPLACEMENT TRANSDUCERS

FEATURES

- Large measuring range: **piston displacements from 50 to 1000 mm** (80 to 250 mm for DI63X models)
- Current-based output signal (4-20 mA) for displacement
- Built-in temperature measurement (VDC output)
- Very long life: No moving parts and therefore no wear of components (Eddy-current principle)
- Insensitive to metallic impurities in the working fluid
- High shock and vibration resistance
- Capable of withstanding pressures up to 450 bar
- Robust construction, designed for permanent operation in hydraulic systems
- Standard temperature version, up to 80 °C (DI5XX)
- High temperature versions, up to 125 °C (DI60X and DI61X) or up to 200 °C (DI63X)
- EMC susceptibility conforms to European standards



Fig. 1: DI632 & DI607 | Displacement transducers

DESCRIPTION

Magtrol's line of Displacement Transducers provide contactless measurement of absolute piston position in hydraulic and pneumatic cylinders and other applications. Their robust construction, large insensitivity to shocks and very long life (due to no moving parts and therefore no wear of components) make them both cost effective and very reliable. Magtrol transducers offer a wide range of operational temperatures and admissible pressure resistance for even the most demanding applications.

The transducer provides a direct 4-20 mA output signal corresponding to the measuring range, as well as VDC temperature output. As an option Magtrol offers the CST 113 Signal Converter, which allows the complete chain to be calibrated according to the specific needs, either in current or voltage output.

APPLICATIONS

The DI Series of displacement transducers were developed principally for OEM applications in the hydraulic industry. They enable the direct and reliable measurement of the position of:

- Hydraulic Cylinders
- Control Valves
- Servo Controls
- Steam Inlet Valves
- Propellers
- Stone Crushers

Their design is such that the installation cost is kept to a minimum. This cost-effectiveness results from the limitation to one fixed standard signal of 4-20 mA with very precise determination of the measurement interval (from 0 to full scale) on the sensing element.

SYSTEM CONFIGURATION

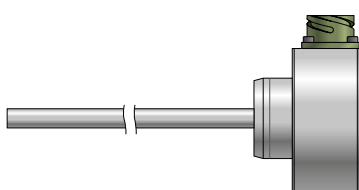

- ← POWER SUPPLY: 20 to 32 VDC / min. 70 mA
- DISPLACEMENT SIGNAL: 4 to 20 mA (20 to 4 mA for DI 63X only)
- TEMPERATURE SIGNAL: 7.5VDC ±80 mV at 20 °C +30mV/°C (DI 5XX)
7.5VDC ±60 mV at 20 °C +10mV/°C (DI 6XX)

OPERATING PRINCIPLES

EDDY-CURRENT PRINCIPLE

Magtrol DI Series Displacement Transducers use the principle of Eddy-current measurement. An aluminum tube moves along the transducer's coil changing the induced Eddy-current losses, thus changing the coil impedance. An electronic circuitry housed in the transducer head, transforms the information of the measuring tube position into a linear signal. This circuitry uses modern SMD (surface-mounted device) technology, giving it robustness and reliability. The sensor is actively compensated for temperature changes.

CHARACTERISTICS OF THE OUTPUT SIGNAL

DI Series Displacement Transducers have a basic 3-wire configuration, providing a 4-20 mA current (20-4 mA for DI63X transducers) proportional to the position of the aluminum tube. An indication of the temperature within the probe is also provided as a voltage output.

In closed-loop systems, a specific piston position can be repeatedly achieved with a precision better than 0.05‰ full scale (e.g. better than 50 μm for a measuring range of 1 m).

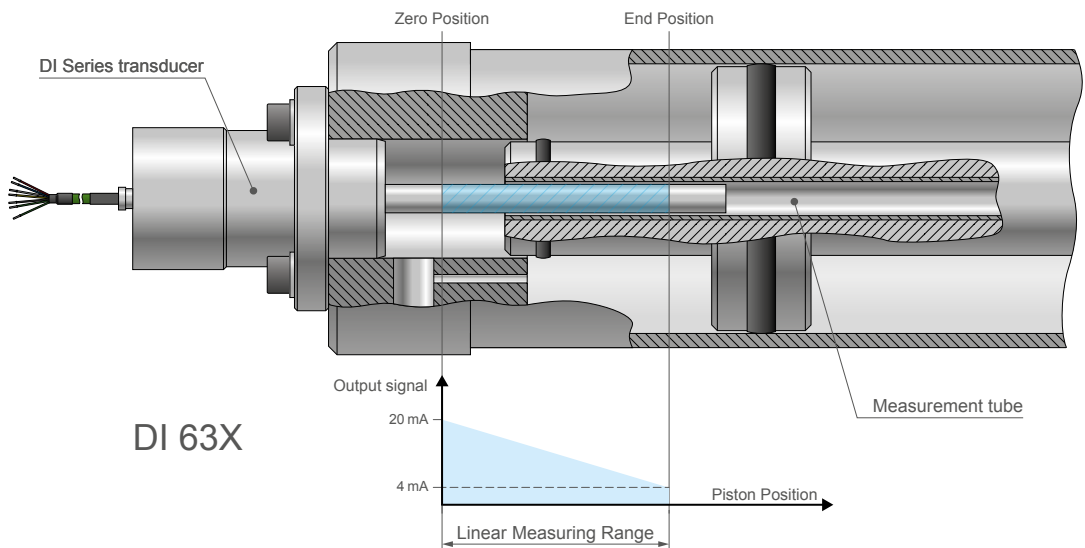
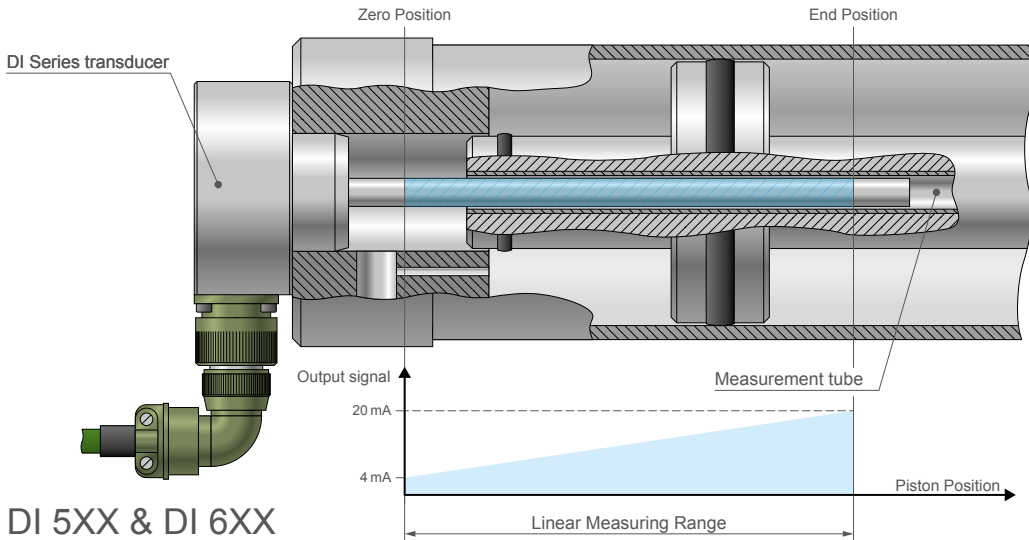

WIRING DIAGRAMS

DI 5XX & DI 6XX TRANSDUCERS

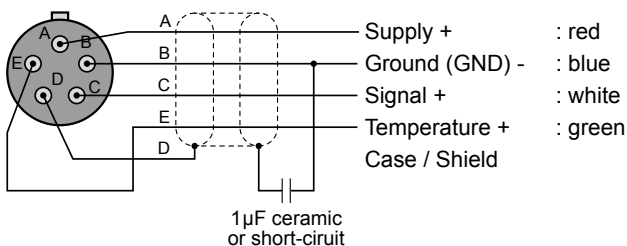

DI 63X TRANSDUCERS

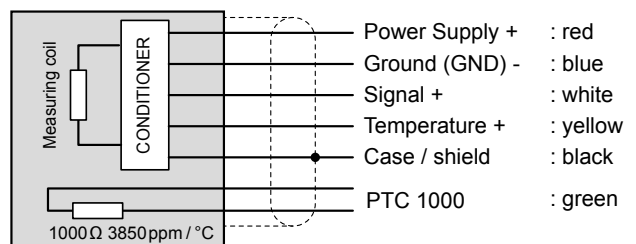

SPECIFICATIONS

MODEL	DI5XX	DI6XX	DI 63X
	Standard Temperature	High Temperature	
MEASURING RANGES ^{a)}			
Rated Values ^{b)}	50, 100, 160, 250, 300, 400, 630, 1000mm	50, 100, 160mm,	80, 130, 200, 250mm,
Zero Position	Defined by inserting the transducer probe into the measurement tube as far as X_{min} ^{a)}		
Full-scale Position	Defined by inserting the transducer probe into the measurement tube as far as X_{max} ^{a)}		
DISPLACEMENT MEASUREMENT			
Linearity Error	0.5%, typically < 1% ^{d)}		
Resolution	< 0.05% ^{d)}		
Repeatability	< 0.05% ^{d)}		
White noise on output current	< 0.2 μA_{eff} / \sqrt{Hz} (DC to 1 kHz)		
OUTPUT SIGNAL ^{c)}			
Displacement Output	Current source with imposed 4 to 20 mA signal. The output current is independent of the load resistance, provided it remains within limits.		
Zero	Adjusted to 4 mA (± 0.08 mA)	Adjusted to 20 mA (± 0.08 mA)	
Full Scale	Adjusted to 20 mA (± 0.15 mA)	Adjusted to 4 mA (± 0.15 mA)	
Admissible Load	0 to 500 Ω		
Frequency Response	0 to 1000 Hz (-1 dB) with 4 th -order Butterworth-type response		0 to 820 Hz (-1 dB) with 4 th -order Butterworth-type response
Temperature Output			
Offset Voltage	7.5 VDC ± 80 mV at 20 °C	7.5 VDC ± 60 mV at 20 °C	
Temperature Signal	30 mV/°C, accuracy $\pm 5\%$ typically ($\pm 10\%$ max.)	10 mV/°C, accuracy $\pm 10\%$ typically ($\pm 20\%$ max.)	10 mV/°C, accuracy $\pm 10\%$ typically ($\pm 15\%$ max.)
Output Resistance	1 k Ω		
ELECTRICAL CHARACTERISTICS & CONNECTIONS			
Supply Voltage	20 to 32 VDC		
Consumption	≤ 70 mA		
Supply Voltage Influence (Displacement)	< 10 ppm of FSD for 1 V variation (DC to 100 Hz)		
Supply Voltage Influence (Temperature)	< 0.1 °C over the range 20 to 32 VDC		
Connection	Watertight 5-pole bayonet connector; Watertight mating plug (straight or elbowed)	7 silicon wires: 0.09 mm ² length: 0.6 m	
Protection Against Polarity Inversion	No danger to the transducer in event of incorrect connection		
ENVIRONMENT & MECHANICAL CHARACTERISTICS			
Operating Temperature	-40 °C to +80 °C	-40 °C to +125 °C	Measuring Rod: -40 °C to +200 °C Electronics: -40 °C to +125 °C
Storage Temperature	-45 °C to +130 °C		
Temperature Influence (Zero)	< 150 ppm/°C ^{d)}		
Temperature Influence (Sensitivity)	< 150 ppm/°C ^{d)}		
Temperature Influence on Drift (zero + sensitivity)	< 1.5% of FSD over the entire operating temperature range		
Maximum Admissible Pressure	450 bar		
Admissible Shock	Half-sine, duration 3 ms, radial 100g, axial 300g		
Protection Class	IP66, according to DIN 40050		
EMC / EMI compatibility	According to IEC 61326-1 / IEC 61321-2-3		

a) Refer to dimension section

b) According to "Linear Measuring Range" dimension (see dimension section)

c) Calibrated standard signal. Transducer and measuring tube are calibrated in the factory for standard measuring ranges mentioned at the top of this table in section «Measuring Ranges»

d) of FSD (Full Scale Deflection)

DIMENSIONS DI 5XX & DI 6XX

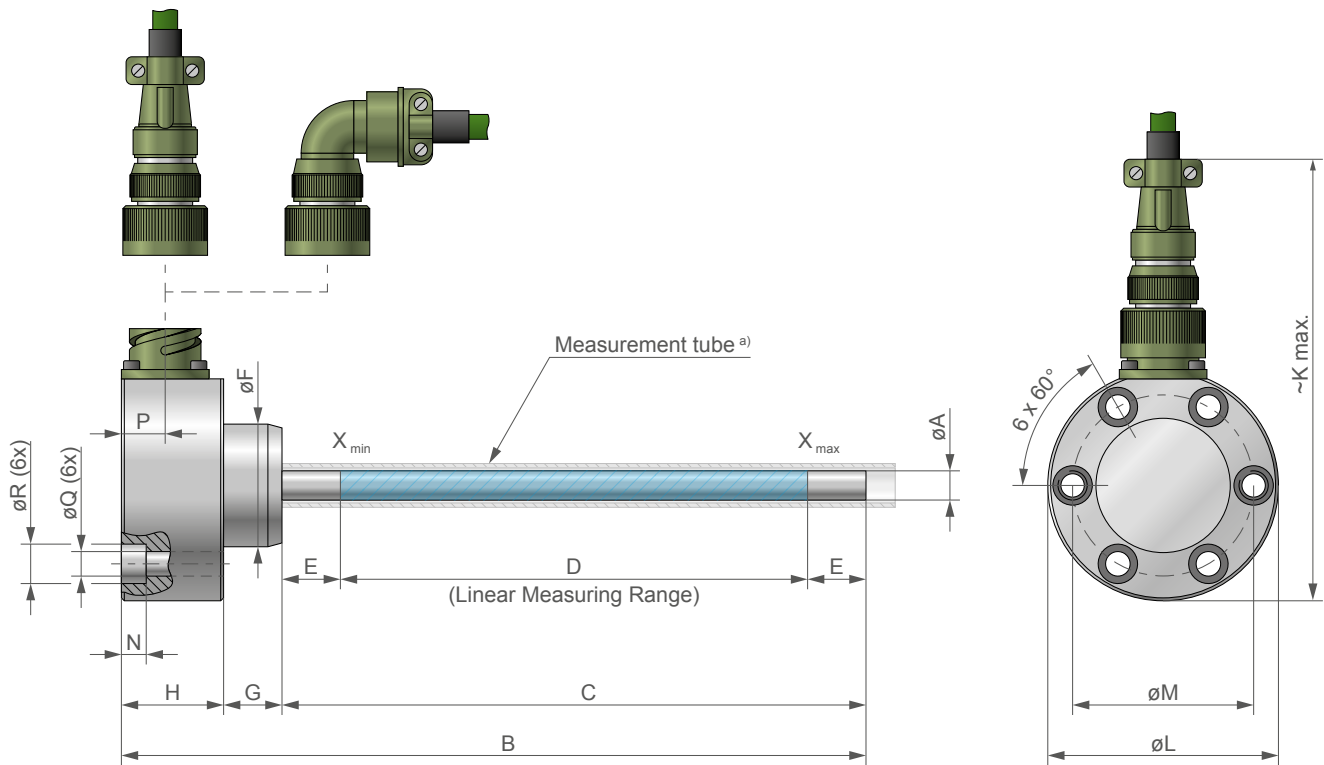

NOTE: Original dimensions are in metric units. Dimensions converted to English units have been rounded up to 4 decimal places.

MODEL	Unit	øA	B	C	D	E	øF	G	H	K	L	M	N	P	øQ	øR	Weight
DI 505	mm	10	145	90	50	20	42m6	20	35	~105	79	62	8.5	15	8.4	13.5	1.15 kg
DI 605	in	0.39	5.71	3.54	1.97	0.79	$\frac{1.6539}{1.6545}$	0.79	1.38	4.13	3.11	2.44	0.335	0.59	0.33	0.53	2.54 lb
DI 510	mm	10	195	140	100	20	42m6	20	35	~105	79	62	8.5	15	8.4	13.5	1.25 kg
DI 610	in	0.39	7.68	5.51	3.94	0.79	$\frac{1.6539}{1.6545}$	0.79	1.38	4.13	3.11	2.44	0.335	0.59	0.33	0.53	2.76 lb
DI 511	mm	10	255	200	160	20	42m6	20	35	~105	79	62	8.5	15	8.4	13.5	1.30 kg
DI 611	in	0.39	10.04	7.87	6.30	0.79	$\frac{1.6539}{1.6545}$	0.79	1.38	4.13	3.11	2.44	0.335	0.59	0.33	0.53	2.87 lb
DI 512	mm	10	345	290	250	20	42m6	20	35	~105	79	62	8.5	15	8.4	13.5	1.40 kg
	in	0.39	13.58	11.41	9.84	0.79	$\frac{1.6539}{1.6545}$	0.79	1.38	4.13	3.11	2.44	0.335	0.59	0.33	0.53	3.09 lb
DI 513	mm	20	505	450	400	25	42m6	20	35	~105	79	62	8.5	15	8.4	13.5	1.85 kg
	in	0.79	19.88	17.72	15.75	0.98	$\frac{1.6539}{1.6545}$	0.79	1.38	4.13	3.11	2.44	0.335	0.59	0.33	0.53	4.08 lb
DI 514	mm	20	735	680	630	25	42m6	20	35	~105	79	62	8.5	15	8.4	13.5	2.20 kg
	in	0.79	28.94	26.77	24.80	0.98	$\frac{1.6539}{1.6545}$	0.79	1.38	4.13	3.11	2.44	0.335	0.59	0.33	0.53	4.86 lb
DI 515	mm	20	1105	1050	1000	25	42m6	20	35	~105	79	62	8.5	15	8.4	13.5	2.60 kg
	in	0.79	43.50	41.33	39.37	0.98	$\frac{1.6539}{1.6545}$	0.79	1.38	4.13	3.11	2.44	0.335	0.59	0.33	0.53	5.73 lb
DI 516	mm	10	395	340	300	20	42m6	20	35	~105	79	62	8.5	15	8.4	13.5	1.70 kg
	in	0.39	15.55	13.39	11.81	0.79	$\frac{1.6539}{1.6545}$	0.79	1.38	4.13	3.11	2.44	0.335	0.59	0.33	0.53	3.75 lb

a) Each DI Series Displacement Transducer is delivered with its dedicated measuring tube.

NOTE: 3D STEP files of most of our products are available on our website: www.magtrol.com ; other files are available on request.

DIMENSIONS DI63X

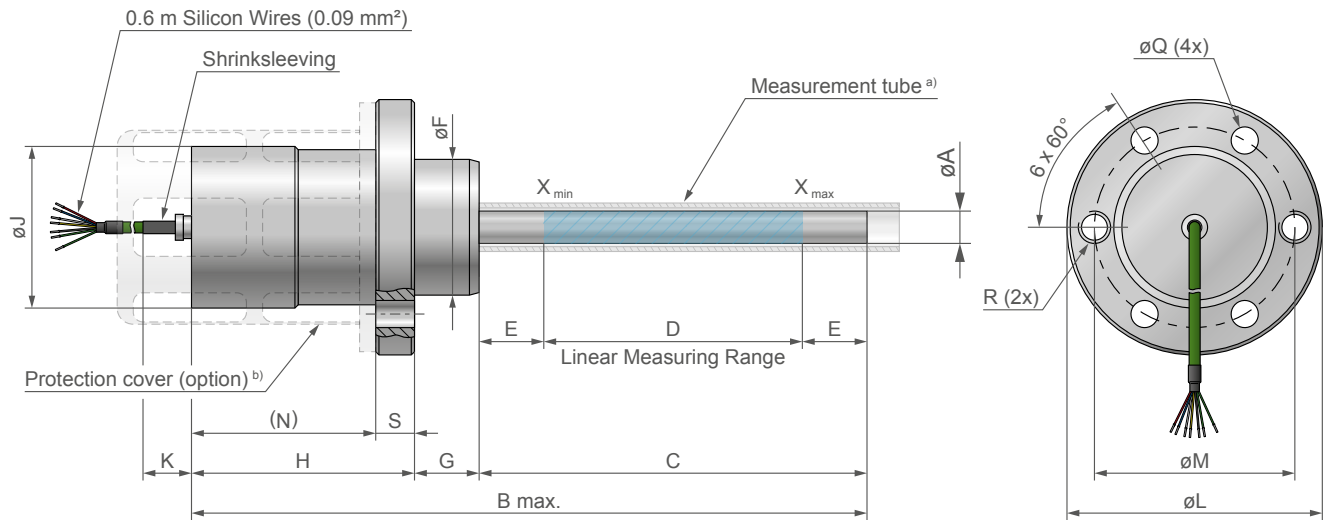

NOTE: Original dimensions are in metric units. Dimensions converted to English units have been rounded up to 4 decimal places.

MODEL	Unit	øA	B	C	D	E	øF	G	H	øJ	K	øL	øM	N	øQ	R	S	Weight
DI 630	mm	10	209	120	80	20	42m6	20	69±0.05	50	15	79	62	57	8.4	M10	12	1.0 kg
	in	0.39	8.23	4.72	3.15	0.79	1.6539 1.6545	0.79	2.7146 2.7185	1.97	0.59	3.11	2.44	2.24	0.33		0.47	2.20 lb
DI 631	mm	10	259	170	130	20	42m6	20	69±0.05	50	15	79	62	57	8.4	M10	12	1.2 kg
	in	0.39	10.20	6.69	5.12	0.79	1.6539 1.6545	0.79	2.7146 2.7185	1.97	0.59	3.11	2.44	2.24	0.33		0.47	2.65 lb
DI 632	mm	10	329	240	200	20	42m6	20	69±0.05	50	15	79	62	57	8.4	M10	12	1.5 kg
	in	0.39	12.95	9.45	7.87	0.79	1.6539 1.6545	0.79	2.7146 2.7185	1.97	0.59	3.11	2.44	2.24	0.33		0.47	3.31 lb
DI 633	mm	10	379	290	250	20	42m6	20	69±0.05	50	15	79	62	57	8.4	M10	12	1.7 kg
	in	0.39	14.92	11.42	9.84	0.79	1.6539 1.6545	0.79	2.7146 2.7185	1.97	0.59	3.11	2.44	2.24	0.33		0.47	3.75 lb

a) Each DI Series Displacement Transducer is delivered with its dedicated measuring tube.

b) The models DI63X are also available with protection cover (see above) and 3 meter cable. Please contact Magtrol.

NOTE: 3D STEP files of most of our products are available on our website: www.magtrol.com ; other files are available on request.

DIMENSIONS DI 5XX WITH THREADED HEAD

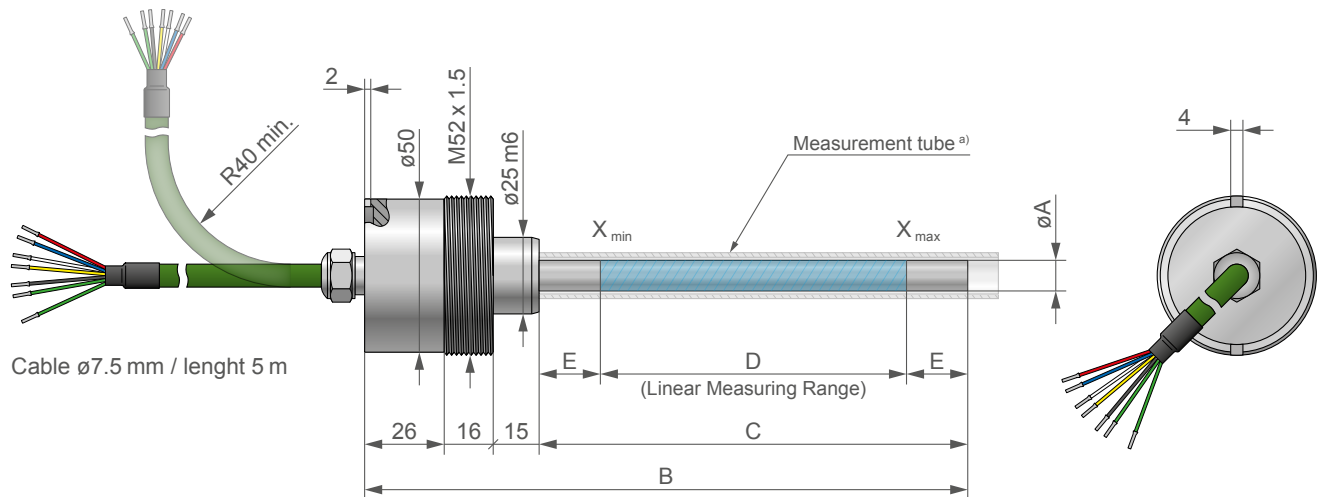

NOTE: Original dimensions are in metric units. Dimensions converted to English units have been rounded up to 2 decimal places.

MODEL	øA		B		C		D		E		Weight
	mm	in	mm	in	mm	in	mm	in	mm	in	
DI 510/S006	10	0.39	197	7.75	140	5.51	100	3.9	20	0.79	
DI 511/S006			257	10.12	200	7.87	160	6.3			
DI 512/S006			347	13.66	290	11.42	250	9.84			
DI 516/S006			397	15.63	340	13.38	300	11.81			

a) Each DI Series Displacement Transducer is delivered with its dedicated measuring tube.

MEASUREMENT TUBES

Magtrol supplies the DI displacement transducer with the appropriate measurement tube, which is manufactured from ENAW-6060 T6 aluminum (AlMgSi0.5). This ensemble constitutes the calibrated system 4-20 mA (20-4 mA for DI 63X).

Measuring tubes are included with each DI transducer.

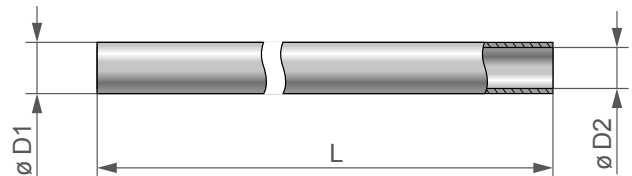

NOTE: Original dimensions are in metric units. Dimensions converted to English units have been rounded up to 4 decimal places.

TRANSDUCER MODEL	ø D1		ø D2		L		PART NUMBER
	mm	in	mm	in	mm	in	
DI 505 / DI 605	13±0.15	0.5157 0.5079	11	0.43	100	3.94	411-505-021-011
DI 510 / DI 610 / DI 510/S006	15±0.15	0.5945 0.5866	12	0.47	150	5.91	411-210-121-011
DI 511 / DI 611 / DI 511/S006					210	8.27	411-211-121-011
DI 512 / DI 633 / DI 512/S006					300	11.81	411-212-121-011
DI 513	26±0.20	1.0283 1.0189	22	0.87	460	18.11	411-213-122-011
DI 514					690	27.17	411-214-122-011
DI 515	28±0.20	1.1102 1.0945	24	0.94	1060	41.73	411-215-123-011
DI 516 / DI 516/S006	15±0.15	0.5945 0.5866	12	0.47	350	13.78	411-216-121-011
DI 630					130	5.12	111-230-901-011
DI 631					175	6.89	111-231-901-011
DI 632					245	9.65	111-232-901-011

NOTE: 3D STEP files of most of our products are available on our website: www.magtrol.com ; other files are available on request.

SYSTEM OPTIONS AND ACCESSORIES

CONNECTION CABLES (DI5XX & DI6XX)

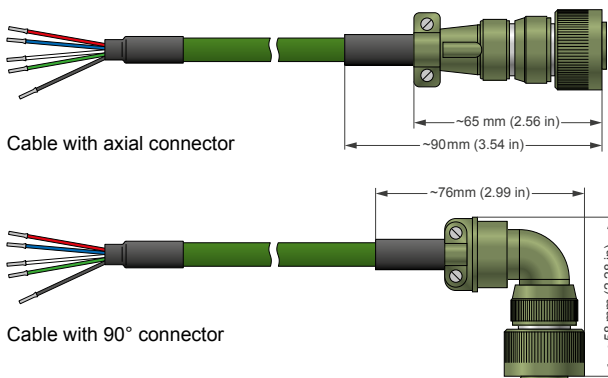

ORDERING NUMBER	EH 14	-	/ X	-
4 :	Axial connector			
5 :	90° connector			
1 :	Cable length 3 m			
2 :	Cable length 5 m			
3 :	Cable length 10 m ^{a)}			

a) Other longer cables lengths available on request.

COUNTER CONNECTOR

Axial connector	PN 957-11-08-0122
90° connector	PN 957-11-08-0132

CST 113 SERIES - SIGNAL CONVERTER



Fig. 3: CST 113 Series version for DIN-Rail

The CST 113 is a signal converter for transducers delivering a signal of 4 to 20 mA. Either a voltage-based signal (I/V conversion) or a current-based signal (I/I) can be chosen as the converter output, along with signal inversion if required. A wide variety of offset and gain values can be selected,

matching many different applications. The use of micro switches (DIP switches) and potentiometers enable easy on-site adjustments and the independent settings make it possible to calibrate the CST 113 in one displacement, from the minimal to the maximum position of the jack.

A « transmission OK » output enables the electrical connection between the DI transducer and the CST 113 converter to be checked, thus allowing the system to be used in applications where safety is important. This operation is simply carried out by measuring the current coming from the DI transducer. An anomaly is indicated by the opening of the output transistor.

The CST 113 power supply input features a galvanic separation to electrically isolate the power supply ground from the measuring chain ground. The CST 113 circuitry is available with either a plastic housing, for mounting on a DIN-rail EN20022-EN50035, or housed in aluminum IP65.

ORDERING NUMBER	CST 113 / 0	-	X	-
1 :	with plastic housing (DIN-rail)			
2 :	with aluminium IP65 housing			
C :	calibrated			

ORDERING INFORMATION

ORDERING NUMBER	DI	---	/	---
510, 511, ..., 633 :	Model number			
/S006 :	Threaded head (only)			

Example: DI512 Displacement Transducers, standard version would be ordered as DI512.

DI512 Displacement Transducers, special threaded head would be ordered as DI512/S006.