



MAGTROL

HD and ED Series Hysteresis Dynamometers



User's Manual

Purchase Record

Please record all model numbers and serial numbers of your Magtrol equipment, along with the general purchase information. The model number and serial number can be found on either a silver identification plate or white label affixed to each unit. Refer to these numbers whenever you communicate with a Magtrol representative about this equipment.

Model Number: _____

Serial Number: _____

Purchase Date: _____

Purchased From: _____

While every precaution has been exercised in the compilation of this document to ensure the accuracy of its contents, Magtrol, Inc./Magtrol SA assumes no responsibility for errors or omissions. Additionally, no liability is assumed for any damages that may result from the use of the information contained within this publication.

COPYRIGHT

Copyright ©2002-2023 Magtrol, Inc. All rights reserved.

Copying or reproduction of all or any part of the contents of this manual without the express permission of Magtrol is strictly prohibited.

TRADEMARKS

LabVIEW™ is a trademark of National Instruments Corporation.

Microsoft® is a registered trademark of Microsoft Corporation.

National Instruments™ is a trademark of National Instruments Corporation.

Windows® is a registered trademark of Microsoft Corporation.

Safety Precautions



Several warning labels are affixed directly to the dynamometer. These warnings are discussed in further detail below. Please take the time to read this page thoroughly before connecting and using your dynamometer.

1. Make sure that all Magtrol dynamometers and electronic products are earth-grounded, to ensure personal safety and proper operation.

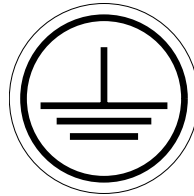

2. Check line voltage before operation on any dynamometer that uses AC input power.
3. Make sure that dynamometers are equipped with a protective cover to prevent contact with the rotating shaft and coupling. The protective cover must be equipped with a safety interlock to disable the test motor if the cover is removed.



4. Make sure that all motors under test are equipped with appropriate safety guards.
5. Use caution with exposed brake surfaces. They have a tendency to become very hot during long periods of operation.



6. Do not lift the unit by the brake assembly, as it may cause damage to the torque sensor.



7. When operating dynamometers with blowers, hearing protection must be worn.



Revisions To This Manual

The contents of this manual are subject to change without prior notice. Should revisions be necessary, updates to all Magtrol User's Manuals can be found at Magtrol's web site at www.magtrol.com/support/manuals.htm.

Please compare the date of this manual with the revision date on the web site, then refer to the manual's Table of Revisions for any changes/updates that have been made since this edition.

REVISION DATE

4th Edition, revision V – October 2023

TABLE OF REVISIONS

Date	Edition	Change	Section(s)
10/31/23	4th Edition - rev. V	Shipping screw information changed for HD-100/HD-106.	3.1.1
07/25/23	4th Edition - rev. U	References to DSP7000 Series changed to DSP7010 Series.	throughout manual
06/06/23	4th Edition - rev. T	Reference to HD-500/700/800 changed to HD-5XX/7XX/8XX. Changes to the shipping bolt updated.	throughout manual
02/06/23	4th Edition - rev. S	Changes to the shipping bolt added.	3.1.1, 3.1.2
03/04/21	4th Edition - rev. R	New cable connector and drawings added. Section removed. Calibration beam and weights table updated.	1.1, 3.3.1, 3.3.2 4.1.3.1 6.2
02/24/21	4th Edition - rev. Q	bit changed to PPR.	throughout manual
02/03/21	4th Edition - rev. P	New cable connectors added.	2.1, 2.2
05/22/18	4th Edition - rev. O	6510e/6530 Power Analyzer references changed to 7500 Series Power Analyzer.	throughout manual
02/18/16	4th Edition - rev. N	HD-805 Dynamometer regulator setting updated for maximum air flow cooling.	4.1.3.2.1
06/11/15	4th Edition - rev. M	Speed sensor board schematic added for 2015 and later dynamometers.	B.2
05/11/15	4th Edition - rev. L	Compressed air regulator setting changed for HD-800 dynamometer.	1.3, 4.1.3.2.1
09/04/14	4th Edition - rev. K	Updated description of booster power amplifier.	5.6.1
06/09/14	4th Edition - rev. J	Note added concerning operation at continuous power rating for long intervals and high temperatures.	4.3.1
02/26/14	4th Edition - rev. I	All references to DSP6001 changed to DSP7000	throughout manual
06/01/12	4th Edition - rev. H	Dimensions were updated on the data sheet for the HD-800 and HD-810 model dynamometers	1.3
05/21/12	4th Edition - rev. G	Part number for the 88M007 and 88M070 cables was changed to 88M007-0150 and 88M070-0150	1.3, 3.3.1, 3.3.2
10/07/08	4th Edition - rev. F	Temperature conditions for maximum power absorption	4.1.3.1
08/31/07	4th Edition - rev. E	Updated electrical power and fuse ratings	1.3
08/31/07	4th Edition - rev. E	New resistance and current values for HD-106	8.1.3.1, 8.1.3.2
08/31/07	4th Edition - rev. E	Added note about circuitry between connector and brake coil	8.1.3.1
06/11/07	4th Edition - rev. D	Deleted: Analog Outputs	7.2, 1.3
03/12/07	4th Edition - rev. C	Updated calibration drawings and procedure	6.4
03/12/07	4th Edition - rev. C	Added new section: "Calibration Beams and Weights"	6.2
02/02/07	4th Edition - rev. B	New "A", "P" and "Q" dimensions for HD-700 series dynamometers	1.3
02/02/07	4th Edition - rev. B	Change in torque, speed and power ratings.	1.3, 4.1.3.1
06/28/06	4th Edition - rev. A	Change in power and speed ratings for HD-805.	1.3, 4.1.3.1
01/23/06	4th Edition	All HD and ED data sheets condensed to one single data sheet.	1.3

01/23/06	4th Edition	HD-515 (compressed air cooled) dynamometer added to product line.	1.3, 2.2, 3.3.3, 3.3.3.2, 4.1.3.1, 4.1.3.2.1, 8.1.3.1, 8.1.3.2
01/23/06	4th Edition	New resistance and current values for HD-500 and HD-505	8.1.3.1, 8.1.3.2
10/12/05	3rd Edition - rev. D	Note to "call factory" for HD-805 power and speed ratings	1.3.3, 4.1.3.1
10/12/05	3rd Edition - rev. D	Change in power rating (5 minutes) for HD-800	1.3.3, 4.1.3.1
02/24/05	3rd Edition - rev.C	Hearing safety warnings added	2.2, 3.3.3.1, 4.1.1, 4.1.3.2.2
12/09/04	3rd Edition - rev.B	Electrical power and fuse ratings added to data sheets	1.3.1–1.3.4
03/11/04	3rd Edition - rev. A	5410 Torque/Speed Readout and 5200/5210 Power Supply removed from manual/open-loop test system configurations	1.3.1–1.3.4, 3.3.1
12/08/03	3rd Edition	HSD Series High Speed Dynamometers discontinued	throughout manual
10/27/03	2nd Edition - rev. E	Change in maximum torque rating for HSD-710-8N	1.3.5, 4.1.3.1
10/27/03	2nd Edition - rev. E	Added short base plate option	1.3.1–1.3.3
10/27/03	2nd Edition - rev. E	Change in speed encoder options	1.3.1–1.3.4
10/02/03	2nd Edition - rev. D	New dimensions for HD-700 series dynamometers	1.3.2
09/25/03	2nd Edition - rev. C	New "B" dimension for HD-400	1.3.1
09/25/03	2nd Edition - rev. C	New "B" and "E" dimensions for HD-106	1.3.1
08/19/03	2nd Edition - rev. B	New schematic drawing for HD-800–815 Brake Control Supply	B.4
03/17/03	2nd Edition - rev. A	New "F" dimension for HSD-610M	1.3.5
03/17/03	2nd Edition - rev. A	New Dynamometer Table added to System Options and Accessories	1.3.1–1.3.5
01/03/03	2nd Edition	Added more information about air cooling – air flow sensor now standard	3.3.3
01/03/03	2nd Edition	Inserted new chapter about optional features	chapter 7
01/03/03	2nd Edition	HSD High Speed Dynamometer information added	throughout manual

Table of Contents

SAFETY PRECAUTIONS	I
REVISIONS TO THIS MANUAL	II
TABLE OF CONTENTS	IV
TABLE OF FIGURES	VI
PREFACE	VI
PURPOSE OF THIS MANUAL.....	VI
WHO SHOULD USE THIS MANUAL.....	VI
MANUAL ORGANIZATION	VI
CONVENTIONS USED IN THIS MANUAL	VII
1. INTRODUCTION	8
1.1 UNPACKING YOUR HYSTERESIS DYNAMOMETER.....	8
1.2 FEATURES OF THE HYSTERESIS DYNAMOMETER	9
1.2.1 HD SERIES.....	9
1.2.2 ED SERIES	9
1.3 DATA SHEETS	10
2. INPUTS/OUTPUTS	31
2.1 REAR PANEL.....	31
2.2 REAR PANEL INPUTS AND OUTPUTS	31
3. INSTALLATION/CONFIGURATION	34
3.1 REMOVAL OF THE LOAD CELL SHIPPING/RESTRAINING BOLT	34
3.1.1 HD-100, AND -400 SERIES	34
3.1.2 HD-500 SERIES	34
3.1.3 HD-700 SERIES	35
3.1.4 HD-800 SERIES	35
3.1.5 ED-715.....	35
3.1.6 ED-815.....	35
3.2 EARTH GROUND	36
3.3 SYSTEM CONFIGURATIONS.....	37
3.3.1 MANUAL TEST SYSTEMS.....	37
3.3.2 PC-BASED TEST SYSTEMS.....	38
3.3.3 AIR COOLING.....	39
4. TESTING	41
4.1 TESTING CONSIDERATIONS	41
4.1.1 SAFETY.....	41
4.1.2 ACCURACY.....	41
4.1.3 POWER DISSIPATION.....	42
4.1.4 FIXTURES AND COUPLINGS	44
4.1.5 WINDAGE.....	44
4.1.6 FRICTION	45
4.1.7 VIBRATION.....	45
4.1.8 COGGING	46

4.1.9	EDDY CURRENTS	46
4.1.10	TEMPERATURE RISE	47
5.	OPERATING PRINCIPLES	48
5.1	SPEED	48
5.2	TORQUE	48
5.3	TORQUE SIGNAL AMPLIFICATION.....	49
5.4	DECIMAL POINT CONTROL	49
5.5	DAMPER CYLINDER	50
5.6	BRAKE CONTROL POWER.....	50
5.6.1	HD-800/815 AND ED-815	50
5.6.2	HD-825	50
6.	CALIBRATION	51
6.1	INITIAL CALIBRATION.....	51
6.2	CALIBRATION BEAMS AND WEIGHTS.....	51
6.3	CALIBRATION PREPARATION.....	52
6.4	CALIBRATION PROCEDURE.....	52
6.5	CALIBRATION FREQUENCY.....	54
7.	OPTIONAL FEATURES	55
7.1	SPEED ENCODER	55
8.	TROUBLESHOOTING.....	56
8.1	TORQUE READOUT PROBLEMS.....	56
8.1.1	NEW DYNAMOMETER	56
8.1.2	ZERO BALANCE.....	56
8.1.3	FULL SCALE TORQUE.....	57
8.1.4	MECHANICAL (ROTATIONAL) ALIGNMENT.....	59
8.2	SPEED READOUT PROBLEMS.....	60
APPENDIX A:	CALIBRATION RECORD	61
APPENDIX B:	SCHEMATICS.....	62
B.1	234-401-101 BOARD.....	62
B.2	SPEED SENSOR BOARD	63
B.3	LOAD CELL SCHEMATIC	64
B.4	HD-800–815 BRAKE CONTROL SUPPLY.....	65
B.5	HD-825 BRAKE CONTROL SUPPLY.....	66
INDEX.....		67
SERVICE INFORMATION.....		69
RETURNING MAGTROL EQUIPMENT FOR REPAIR AND/OR CALIBRATION		69
RETURNING EQUIPMENT TO MAGTROL, INC. (UNITED STATES).....		69
RETURNING EQUIPMENT TO MAGTROL SA (SWITZERLAND)		69

TABLE OF FIGURES
TABLE OF FIGURES**2. INPUTS/OUTPUTS**

<i>Figure 2-1 Rear Panel</i>	31
<i>Figure 2-2 Dynamometer Brake Input</i>	31
<i>Figure 2-3 Prior to 2020 Dynamometer Brake Input</i>	31
<i>Figure 2-4 Dynamometer Connector</i>	32
<i>Figure 2-5 Prior to 2020 Dynamometer Connector</i>	32
<i>Figure 2-6 Calibration Potentiometers</i>	32
<i>Figure 2-7 Speed Encoder Switch</i>	32
<i>Figure 2-8 Blower Input</i>	33
<i>Figure 2-9 Compressed Air Input</i>	33

3. INSTALLATION/CONFIGURATION

<i>Figure 3-1 HD 500 Series Shipping/Restraining Bolt Location</i>	34
<i>Figure 3-2 HD-700 Series Shipping/Restraining Bolt Location</i>	35
<i>Figure 3-3 ED-715 Shipping/Restraining Bolt Location</i>	35
<i>Figure 3-4 HD 100-500 Series Top View</i>	36
<i>Figure 3-5 HD-800 Series Top View</i>	36
<i>Figure 3-6 Dynamometer with 6200 Controller</i>	37
<i>Figure 3-7 Dynamometer with DSP7001 Controller and M-TEST Software</i>	38
<i>Figure 3-8 Dynamometer with 7510 Power Analyzer, DSP7001 Controller and M-TEST Software</i>	38
<i>Figure 3-9 Air Flow Sensor Schematic</i>	39
<i>Figure 3-10 Dynamometer with Blower Connection</i>	40
<i>Figure 3-11 Dynamometer with Compressed Air Connection</i>	40

4. TESTING

<i>Figure 4-1 Dynamometer with Compressed Air Connection</i>	43
<i>Figure 4-2 Dynamometer with Blower Connection</i>	43
<i>Figure 4-3 Examples of Possible Shaft Misalignment</i>	44
<i>Figure 4-4 Hysteresis Brake Cross-Section</i>	46

5. OPERATING PRINCIPLES

<i>Figure 5-1 Mechanical Layout of a Load Cell</i>	48
--	----

6. CALIBRATION

<i>Figure 6-1 Calibration Label</i>	51
<i>Figure 6-2 Calibration Setup</i>	52
<i>Figure 6-3 Calibration Potentiometers</i>	53
<i>Figure 6-4 Calibration Calculation</i>	53

7. OPTIONAL FEATURES

<i>Figure 7-1 Speed Encoder Schematic</i>	55
---	----

8. TROUBLESHOOTING

<i>Figure 8-1 Damper Connection</i>	59
---	----

Preface

PURPOSE OF THIS MANUAL

This manual contains all the information required for the setup and general use of Magtrol's Hysteresis Dynamometers. To achieve maximum capability and ensure proper use of the dynamometer, please read this manual in its entirety before operating. Keep the manual in a safe place for quick reference whenever a question should arise.

WHO SHOULD USE THIS MANUAL

This manual is intended for those operators who are planning to use any of Magtrol's Hysteresis Dynamometers.

MANUAL ORGANIZATION

This section gives an overview of the structure of the manual and the information contained within it. Some information has been deliberately repeated in different sections of the document to minimize cross-referencing and to facilitate understanding through reiteration.

The structure of the manual is as follows:

- Chapter 1: INTRODUCTION – Contains the technical data sheets for Magtrol's Hysteresis Dynamometers, which describe the units and provide detailed technical characteristics.
- Chapter 2: INPUTS/OUTPUTS – Description of the elements located on the rear panel of the dynamometer.
- Chapter 3: INSTALLATION/CONFIGURATION – Provides information needed for setup of the dynamometer. This includes load cell shipping/restraining bolt removal, earth ground instruction and configurations for manual, computer-controlled and air-cooled test setups.
- Chapter 4: TESTING – Provides information on how to run a test along with considerations that should be taken when operating the dynamometer.
- Chapter 5: OPERATING PRINCIPLES – Information pertaining to theory of operation including speed, torque, torque signal amplification, decimal point control, damper cylinder and brake control power.
- Chapter 6: CALIBRATION – Provides recommended calibration schedules along with step-by-step instructions for the calibration procedure.
- Chapter 7: OPTIONAL FEATURES – Provides information regarding various optional features available to enhance the capability of Magtrol's Hysteresis Dynamometers including speed encoders and analog outputs.
- Chapter 8: TROUBLESHOOTING – Solutions to common problems encountered during setup and testing.
- Appendix A: CALIBRATION RECORD – Data sheet for tracking calibration results.
- Appendix B: SCHEMATICS – For the torque amplification board, speed sensor board, load cell and brake control power supplies.

CONVENTIONS USED IN THIS MANUAL

The following symbols and type styles may be used in this manual to highlight certain parts of the text:



Note: This is intended to draw the operator's attention to complementary information or advice relating to the subject being treated. It introduces information enabling the correct and optimal function of the product.



CAUTION: THIS IS USED TO DRAW THE OPERATOR'S ATTENTION TO INFORMATION, DIRECTIVES, PROCEDURES, ETC. WHICH, IF IGNORED, MAY RESULT IN DAMAGE TO THE MATERIAL BEING USED. THE ASSOCIATED TEXT DESCRIBES THE NECESSARY PRECAUTIONS TO TAKE AND THE CONSEQUENCES THAT MAY ARISE IF THESE PRECAUTIONS ARE IGNORED.



WARNING! THIS INTRODUCES DIRECTIVES, PROCEDURES, PRECAUTIONARY MEASURES, ETC. WHICH MUST BE EXECUTED OR FOLLOWED WITH THE UTMOST CARE AND ATTENTION, OTHERWISE THE PERSONAL SAFETY OF THE OPERATOR OR THIRD PARTY MAY BE AT RISK. THE READER MUST ABSOLUTELY TAKE NOTE OF THE ACCOMPANYING TEXT, AND ACT UPON IT, BEFORE PROCEEDING FURTHER.



WHEN HEARING PROTECTION IS REQUIRED, THE STOP SIGN IS REPLACED WITH THE EAR MUFF SYMBOL.

1. Introduction

1.1 UNPACKING YOUR HYSTERESIS DYNAMOMETER

Your Hysteresis Dynamometer was packaged in reusable, shock resistant packing material that will protect the instrument during normal handling.

1. Make sure the carton contains the following:

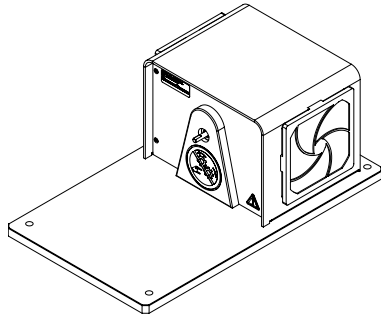

Hysteresis Dynamometer

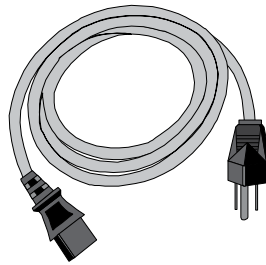

Line Cord
(not included with 7XX series or HD-825)

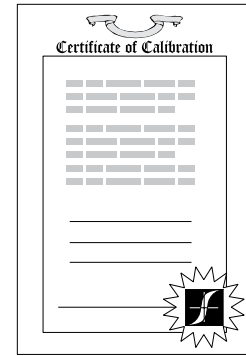

Calibration Certificate



Signal Cable



Brake Cable

2. Inspect the contents for any evidence of damage in shipping. In the event of shipping damage, immediately notify the carrier and Magtrol's Customer Service Department.



Note: Save all shipping cartons and packaging material for reuse when returning the instrument for calibration or servicing.

3. Remove the Shipping Bolt

PLEASE TAKE NOTICE!

Before proceeding any further, you will need to remove the load cell shipping/restraining bolt if you have just unpacked a new:

HD-100	HD-500	HD-515	HD-710
HD-106	HD-505	HD-700	HD-715
HD-400	HD-510	HD-705	ED-715

This does not apply to HD-800, HD-805, HD-810, HD-815, HD-825 or ED-815 Dynamometers. For further instruction see Section 3.1 Removal of the Load Cell Shipping/Restraining Bolt.

Note: Retain the shipping/restraining bolt for future use when moving or shipping your Magtrol Dynamometer.

1.2 FEATURES OF THE HYSTERESIS DYNAMOMETER

All Magtrol Hysteresis Dynamometers (HD and ED Series) feature the following:

- **Hysteresis Braking System:** The dynamometers do not require speed to create torque, and therefore can provide a full motor ramp from free-run to locked rotor along with precise torque loading.
- **Air Flow Sensor:** Any Magtrol Hysteresis Dynamometer that is internally ported for compressed air and/or blower cooling contains an air flow sensor that provides protection against overheating and operator error
- **Standard Torque Units:** English, metric and SI are available.
- **Easy Calibration**

Unique features of each series are listed below.

1.2.1 HD SERIES

Magtrol's HD Series Dynamometers are versatile and ideal for testing in low to medium power ranges. Features include:

- **Accuracy:** $\pm 0.25\%$ to $\pm 0.5\%$ full scale, depending on size and system configuration.
- **Custom Dynamometers:** For special torque and speed requirements.
- **Encoder Switch:** Optional feature that allows the user to switch between a 60 and 600-PPR encoder or a 60 and 6000-PPR encoder.

1.2.2 ED SERIES

Magtrol's ED Series Dynamometers are high performance dynamometers specifically designed to address the severe, high vibration conditions inherent in internal combustion engine testing. Features include:

- **Accuracy:** $\pm 0.25\%$ full scale.
- **High Speed Capabilities:** 12,000 to 25,000 rpm, depending on model.
- **Rugged Stainless Steel Shaft:** Larger shaft for additional strength.
- **Specially Reinforced Load Cell:** Stainless steel pin used at contact point to prevent premature wear from excess vibration.
- **Gusseted Pillow Blocks:** Adds additional front and rear support.
- **Brake Cooling:** Blower cooled to maximize heat dissipation.

1.3 DATA SHEETS

HD SERIES HYSTERESIS DYNAMOMETERS

MAGTROL offers 3 types of dynamometer brakes to absorb load: Hysteresis (**HD Series**), Eddy-Current (**WB Series**) and Magnetic Powder (**PB Series**). Each type of Dynamometer has advantages and limitations and choosing the correct one will depend largely on the type of testing to be performed. With over 50 standard models to choose from, Magtrol Sales professionals are readily available to assist in selecting the proper Dynamometer to meet your testing needs.

FEATURES

- 16 Standard Models with Maximum Torque from 2.5 oz·in to 500 lb·in (18 mN·m to 56.5 N·m)
- 14 High Speed Models Available
- Hysteresis Braking System: provides precise torque loading independent of shaft speed
- Motor Testing: from no load to locked rotor
- Standard Torque Units: SI (English & Metric available upon request)
- Accuracy: $\pm 0.25\%$ (full scale)
- Air Flow Sensor: For protection against overheating and operator error
- Base Plates: available in long or short versions
- Custom Dynamometers: for special torque and speed requirements
- Easy Calibration



Fig. 1: HD-715 | Hysteresis Dynamometer

DESCRIPTION

Hysteresis Brake Dynamometers (HD Series) are versatile and ideal for testing in the low to medium power range (maximum 14 kW intermittent duty). With a Hysteresis Braking system, the Dynamometers do not require speed to create torque, and therefore can provide a full motor ramp from free-run to locked rotor. Brake cooling is provided by convection (no external source), by compressed air or by dedicated blower, depending on the model. All Magtrol Hysteresis Dynamometers have accuracy ratings of $\pm 0.25\%$ (full scale) depending on size and system configuration.

To better integrate dynamometers into systems, Magtrol offers both long and short base plates. The shorter base plate facilitates easier motor mounting when used with T-slot tables and Magtrol Adjustable Motor Fixtures, where as the long base plates are better suited for table top testing.

APPLICATIONS

Magtrol motor test systems can be found in test labs, at inspection stations, and on the manufacturing floors of most of the world's leading manufacturers, users and certifiers of small to medium sized electric, pneumatic and hydraulic motors, as well as internal combustion engines. Magtrol supplies motor test systems for a wide array of industries including: Appliance, Automotive, Aviation, Computer, HVAC, Lawn and Garden, Medical and Dental, Electric Motor, Office Equipment and Power Tools.



HD SERIES

GENERAL INFORMATION

DYNAMOMETER SELECTION

Magtrol's Hysteresis Dynamometers cover a wide range of Torque, Speed and Mechanical Power ratings. To select the appropriate size Dynamometer for your motor testing needs, you will need to determine the **Maximum Torque, Speed and Power** applied to the Dynamometer.

MAXIMUM TORQUE

The Magtrol Hysteresis Absorption Dynamometer will develop braking torque at any speed point, including low speed and stall conditions ("0" rpm). It is important to consider all torque points that are to be tested, not only rated torque, but also locked rotor and breakdown torque. Dynamometer selection should initially be based on the maximum torque requirement, subject to determining the maximum power requirements.

MAXIMUM SPEED

This rating is to be considered independent of torque and power requirements, and is the maximum speed at which the Dynamometer can be safely run under free-run or lightly loaded conditions. It is not to be considered as the maximum speed at which full braking torque can be applied.

To safely dissipate heat and avoid Dynamometer failure, the maximum power rating is the most important consideration in selecting a Dynamometer.

MAXIMUM POWER RATINGS

These ratings represent the maximum capability of the Dynamometer Braking System to absorb and dissipate heat generated when applying a braking load to the motor under test. The power absorbed and the heat generated by the Dynamometer is a function of the Torque (**T**) applied to the motor under test, and the resulting Speed (**n**) of the motor. This is expressed in these Power (**P**) formulas:

$$\begin{aligned} \text{SI: } P[W] &= T[N \cdot m] \times n[\text{min}^{-1}] \times (1.047 \times 10^{-1}) \\ \text{English: } P[W] &= T[\text{lb} \cdot \text{in}] \times n[\text{rpm}] \times (1.183 \times 10^{-2}) \\ \text{Metric: } P[W] &= T[\text{kg} \cdot \text{cm}] \times n[\text{rpm}] \times (1.027 \times 10^{-2}) \end{aligned}$$

All of Magtrol's controllers, readouts and software calculate horsepower as defined by 1 [hp] = 550 [lb-ft/s].

$$\text{Using this definition: } P[\text{hp}] = P[W] / 745.7$$

The Dynamometer's ability to dissipate heat is a function of how long a load will be applied. For this reason, the maximum power ratings given are based on continuous operation under load, as well as a maximum of 5 minutes under load.

OPERATING PRINCIPLES

Magtrol Hysteresis Dynamometers absorb power with a unique Hysteresis Braking System which provides frictionless torque loading independent of shaft speed. The Hysteresis Brake provides torque by the use of two basic components - a reticulated pole structure and a specialty steel rotor/shaft assembly - fitted together but not in physical contact.

Until the pole structure is energized, the drag cup can spin freely on its shaft bearings. When a magnetizing force from the field coil is applied to the pole structure, the air gap becomes a flux field and the rotor is magnetically restrained, providing a braking action between the pole structure and rotor.

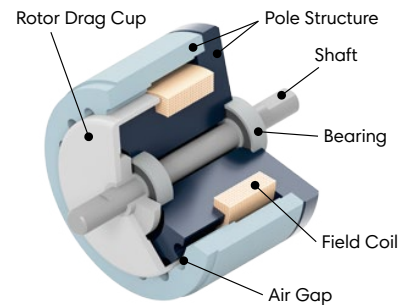

M-TEST - MOTOR TESTING SOFTWARE

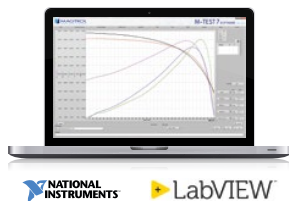

Magtrol's M-TEST Software is a state-of-the-art motor testing program for Windows®-based data acquisition. Used with a Magtrol DSP7010 Dynamometer Controller, Magtrol M-TEST Software provides the control of any Magtrol Dynamometer and

runs test sequences in a manner best suited to the overall accuracy and efficiency of the Magtrol Motor Test System. The data that is generated by Magtrol's Motor Testing Software can be stored, displayed and printed in tabular or graphic formats, and can be easily imported into a spreadsheet.

Written in LabVIEW™, M-TEST has the flexibility to test a majority of motor types in a variety of ways. Because of LabVIEW's versatility, obtaining data from other sources (e.g. thermocouples), controlling motor power and providing audio/visual indicators is relatively easy.

Magtrol's M-TEST Software is ideal for simulating loads, cycling the unit under test and motor ramping. Because it is easy to gather data and duplicate tests, the software is ideal for use in engineering labs. Tests can be programmed to run on their own and saved for future use allowing for valuable time savings in production testing and incoming/outgoing inspection.



HD SERIES

SYSTEM CONFIGURATIONS

OPEN LOOP SYSTEMS

Magtrol offers both open loop manual test systems and PC-based closed loop test systems. A typical open loop system consist of a Dynamometer and a Magtrol DSP 7010 Dynamometer Controller in Open-Loop configuration. A Magtrol Single or Three-Phase Power Analyzer, which allows for the capturing

of volts, amps, watts and power factor, can be included as an option. An open loop system is often used for quick pass/fail testing on the production line or at incoming inspection. Magtrol's DSP 7010 Dynamometer Controller provides pass/fail testing as a standard feature.

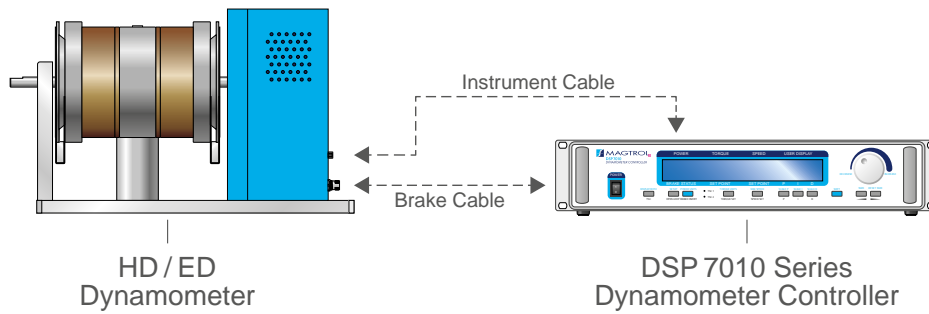

Fig. 2: Dynamometer with DSP 7010 Dynamometer Controller

CLOSED LOOP SYSTEMS

In a closed loop motor test system, data is collected on a PC using Magtrol's M-TEST Software, DSP 7010 Dynamometer Controller, and requisite interface cards and cables. Magtrol's DSP 7010 Dynamometer Controllers compute and display mechanical power (in horsepower or watts) in addition to torque

and speed. A Single or Three Phase Power Analyzer, a required component in a test system measuring motor efficiency, can be integrated into this system as well as Magtrol's Temperature Testing Hardware.

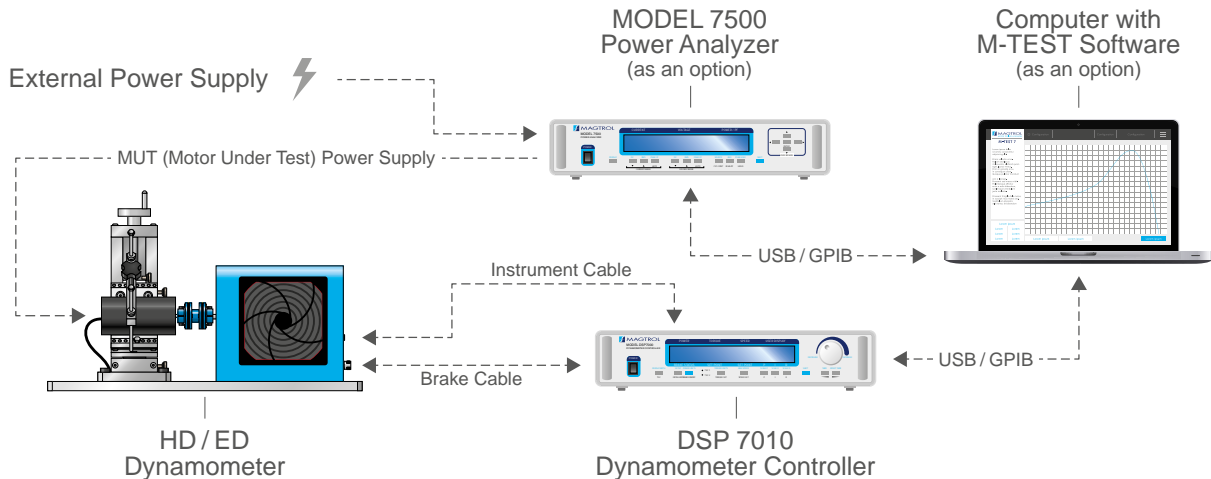

Fig. 3: Dynamometer with MODEL7500 Power Analyzer, DSP 7010 Dynamometer Controller and M-TEST Software



HD SERIES

GENERAL INFORMATION

SPECIFICATIONS

HYSTERESIS DYNAMOMETER RATINGS											
MODELS	TORQUE MEASURE UNIT CODE ^{a)}	MAXIMUM TORQUE RANGE	DRAG TORQUE DE-ENERGIZED AT 1000 rpm	NOMINAL INPUT INERTIA		MAX. POWER RATINGS		MAXIMUM SPEED ^{e)}		BRAKE COOLING METHOD	
				N-m	mN-m	lb-ft-s ²	kg-m ²	5min W	CONTINUOUS ^{b)} W		STANDARD rpm
HD-106	5C	0.018	0.056	4.72 x 10 ⁻⁷	6.35 x 10 ⁻⁷	35	7	30 000	50 000	Convection	
HD-100	5C	0.08	0.64	3.40 x 10 ⁻⁶	4.61 x 10 ⁻⁶	75	20	25 000	40 000	Convection	
HD-400	5C	0.28	2	1.55 x 10 ⁻⁵	2.10 x 10 ⁻⁵	200	55			Convection	
HD-500	5C	0.85	5	8.05 x 10 ⁻⁵	1.09 x 10 ⁻⁴	400	80			Convection	
HD-510	5C			8.05 x 10 ⁻⁵	1.09 x 10 ⁻⁴	750	375			Compressed Air ^{c)} (7 CFM @ 1.75 PSI)	
HD-505	5C	1.7	10	1.61 x 10 ⁻⁴	2.18 x 10 ⁻⁴	800	160			Convection	
HD-515	5C			1.61 x 10 ⁻⁴	2.18 x 10 ⁻⁴	1500	900			Compressed Air ^{c)} (10 CFM @ 4 PSI)	
HD-700	5C	3.1	13	5.51 x 10 ⁻⁴	7.47 x 10 ⁻⁴	700	150			35 000	Convection
HD-710	5C			5.51 x 10 ⁻⁴	7.47 x 10 ⁻⁴	1500	935				Blower ^{d)}
HD-705	5C	6.2	23	1.10 x 10 ⁻³	1.49 x 10 ⁻³	1400	300				Convection
HD-715	5C			1.10 x 10 ⁻³	1.49 x 10 ⁻³	3400	3000				Blower ^{d)}
HD-800	5C	14.0	100	4.43 x 10 ⁻³	6.01 x 10 ⁻³	2800	1800	12 000	N/A	Compressed Air ^{c)} (13 CFM @ 10 PSI)	
HD-810	5C			4.43 x 10 ⁻³	6.01 x 10 ⁻³	3500	3000		15 000	Blower ^{d)}	
HD-805	5C	28.0	140	8.81 x 10 ⁻³	1.19 x 10 ⁻²	5300	2250		N/A	Compressed Air ^{c)} (15 CFM @ 14 PSI)	
HD-815	5C			8.81 x 10 ⁻³	1.19 x 10 ⁻²	7000	6000	15 000	Blower ^{d)}		
HD-825	5C	56.5	400	1.85 x 10 ⁻²	2.51 x 10 ⁻²	14000	12000	8000	10000	Blower ^{d)}	

- a) All -5C dynamometers are 5 Volt Output. Please, contact our sales representative for 6C (English units), 7C (Metric units) or 8C (SI units) specifications.
- b) Operating at the continuous power rating for periods of up to 4 hours is acceptable. However, operating for extended periods at high temperatures will result in premature component and bearing failure. Limiting the length of the cycle and the component temperatures will guard against premature failure. Where continuous duty is desired for longer time intervals, component temperatures should be maintained less than 100°C; monitoring the outside brake surface temperature is a sufficient reference.
- c) Requires air cooling provided by user. Regulator and filter package is provided as standard
- d) Blower is included
- e) The maximum speed will depend on what type of keyway (if any) is used on the shaft. Unless specified, the dynamometer shaft will be made without a keyway.

ELECTRICAL POWER		
MODELS	VOLTAGE	VA
HD-1XX-5C1, HD-4XX-5C1, HD-5XX-5C1	120V	30
HD-1XX-5C2, HD-4XX-5C2, HD-5XX-5C2	240V	
HD-800-5C1, HD-810-5C1	120V	65
HD-800-5C2, HD-810-5C2	240V	
HD-805-5C1, HD-815-5C1	120V	130
HD-805-5C2, HD-815-5C2	240V	
HD-825-5C1	120V	N/A
HD-825-5C2	240V	



HD SERIES

DIMENSIONS HD-100/400/500

HD-100/400/500 SERIES WITH LONG BASE PLATE

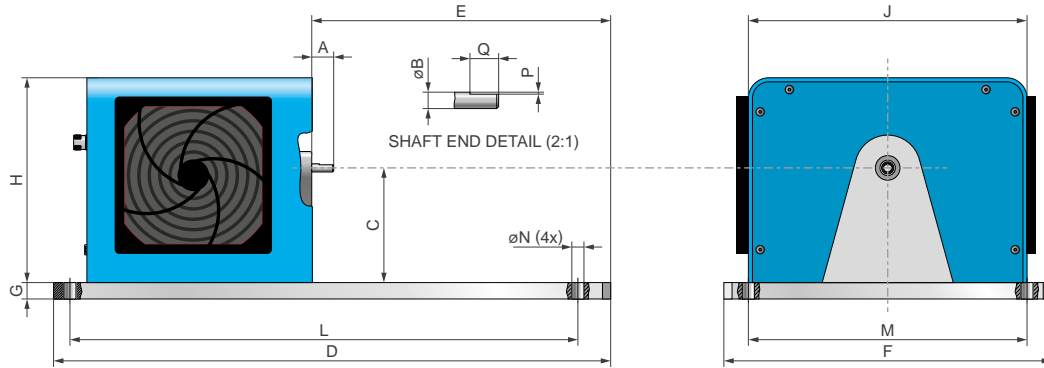

NOTE: Original dimensions are in English units. Dimensions converted to Metric units have been rounded and are for reference only.

MODELS	units	A	øB	C	D	E	F	G	H	J	L ^{a)}	M ^{a)}	øN	P	Q	Weight
HD-106	in	0.50	0.1245 0.1247	3.5	17	9.38	10	0.5	6.3	8.5	15.5	8.5	0.37	0.015	0.375	12.0 lb
	mm	12.7	3.162 3.167	88.9	432	238.3	254	12.7	159	216	394	216	9.4	0.38	9.53	5.4 kg
HD-100	in	0.75	0.1870 0.1872	3.5	17	9.13	10	0.5	6.3	8.5	15.5	8.5	0.37	0.025	0.375	12.5 lb
	mm	19.1	4.750 4.755	88.9	432	231.9	254	12.7	159	216	394	216	9.4	0.64	9.53	5.7 kg
HD-400	in	0.67	0.2495 0.2497	3.5	17	9.13	10	0.5	6.3	8.5	15.5	8.5	0.37	0.03	0.438	15.0 lb
	mm	17.0	6.337 6.342	88.9	432	231.9	254	12.7	159	216	394	216	9.4	0.76	11.13	6.8 kg
HD-500	in	0.88	0.3745 0.3750	4.0	17	9.13	10	0.5	6.3	8.5	15.5	8.5	0.37	0.047	0.375	16.0 lb
	mm	22.2	9.512 9.525	101.6	432	231.9	254	12.7	159	216	394	216	9.4	1.19	9.53	7.3 kg
HD-510	in	0.88	0.3745 0.3750	4.0	17	9.13	10	0.5	6.3	8.5	15.5	8.5	0.37	N/A ^{b)}		16.0 lb
	mm	22.2	9.512 9.525	101.6	432	231.9	254	12.7	159	216	394	216	9.4	N/A ^{b)}		7.3 kg
HD-505	in	0.88	0.3745 0.3750	4.0	20	9.64	10	0.5	6.3	8.5	18.5	8.5	0.37	0.05	0.375	18.0 lb
	mm	22.2	9.512 9.525	101.6	508	244.9	254	12.7	159	216	470	216	9.4	1.27	9.53	8.1 kg
HD-515	in	0.88	0.3745 0.3750	4.0	20	9.64	10	0.5	6.3	8.5	18.5	8.5	0.37	N/A ^{b)}		18.0 lb
	mm	22.2	9.512 9.525	101.6	508	244.9	254	12.7	159	216	470	216	9.4	N/A ^{b)}		8.1 kg

a) These dimensions represent the distance between mounting holes. There are four (4) mounting holes on each base plate.

b) Shaft Flats are not available on high speed models.

NOTE: 3D STEP files of most of our products are available on our website: www.magtrol.com ; other files are available on request.



HD SERIES

DIMENSIONS HD-100/400/500

HD-100/400/500 SERIES WITH SHORT BASE PLATE

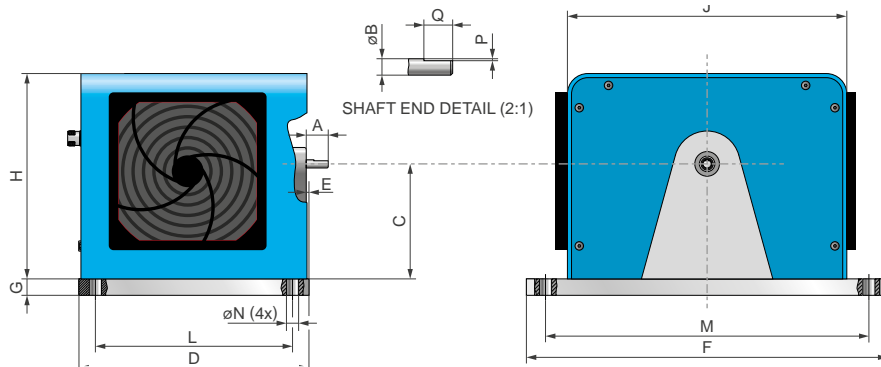

Fig. 4: HD-400 Dynamometer with short base plate

NOTE: Original dimensions are in English units. Dimensions converted to Metric units have been rounded and are for reference only.

MODELS	units	A	øB	C	D	E	F	G	H	J	L ^{a)}	M ^{a)}	øN	P	Q	Weight
HD-106	in	0.50	0.1245 0.1247	3.5	7.0	0.33	11	0.5	6.3	8.5	6.0	9.84	0.35	0.015	0.375	7.5 lb
	mm	12.7	3.162 3.167	88.9	177.8	8.4	279.4	12.7	159	216	152.4	250	9	0.38	9.53	3.4 kg
HD-100	in	0.75	0.1870 0.1872	3.5	7.0	0.08	11	0.5	6.3	8.5	6.0	9.84	0.35	0.025	0.375	8.0 lb
	mm	19.1	4.750 4.755	88.9	177.8	2.1	279.4	12.7	159	216	152.4	250	9	0.64	9.53	3.6 kg
HD-400	in	0.67	0.2495 0.2497	3.5	7.0	0.08	11	0.5	6.3	8.5	6.0	9.84	0.35	0.03	0.438	11.0 lb
	mm	17.0	6.337 6.342	88.9	177.8	2.1	279.4	12.7	159	216	152.4	250	9	0.76	11.13	5.0 kg
HD-500	in	0.88	0.3745 0.3750	4.0	7.0	0.08	11	0.5	6.3	8.5	6.0	9.84	0.35	0.047	0.375	12.0 lb
	mm	22.2	9.512 9.525	101.6	177.8	2.1	279.4	12.7	159	216	152.4	250	9	1.19	9.53	5.4 kg
HD-510	in	0.88	0.3745 0.3750	4.0	8.0	0.13	11	0.5	6.3	8.5	7.0	9.84	0.35	N/A ^{b)}		12.5 lb
	mm	22.2	9.512 9.525	101.6	203.2	3.2	279.4	12.7	159	216	177.8	250	9	N/A ^{b)}		5.7 kg
HD-505	in	0.88	0.3745 0.3750	4.0	9.5	0.10	11	0.5	6.3	8.5	8.5	9.84	0.35	0.05	0.375	13.0 lb
	mm	22.2	9.512 9.525	101.6	241.3	2.6	279.4	12.7	159	216	215.9	250	9	1.27	9.53	5.9 kg
HD-515	in	0.88	0.3745 0.3750	4.0	10.25	0.10	11	0.5	6.3	8.5	9.25	9.84	0.35	N/A ^{b)}		13.0 lb
	mm	22.2	9.512 9.525	101.6	260.4	2.6	279.4	12.7	159	216	234.9	250	9	N/A ^{b)}		5.9 kg

a) These dimensions represent the distance between mounting holes. There are four (4) mounting holes on each base plate.

b) Shaft Flats are not available on high speed models.

NOTE: 3D STEP files of most of our products are available on our website: www.magtrol.com ; other files are available on request.



HD SERIES

GENERAL INFORMATION

DIMENSIONS HD-700

HD-700 SERIES WITH LONG BASE PLATE

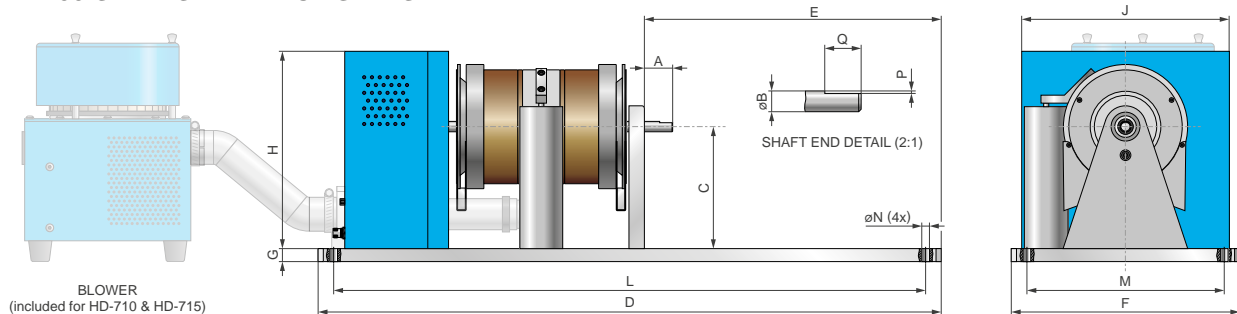

HD-700 SERIES WITH SHORT BASE PLATE

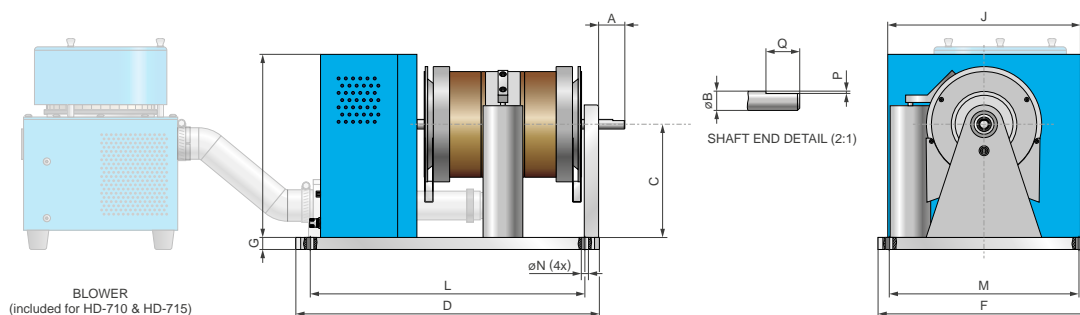

NOTE: Original dimensions are in English units. Dimensions converted to Metric units have been rounded and are for reference only.

MODELS	units	A	øB	C	D	E	F	G	H	J	L ^{a)}	M ^{a)}	øN	P	Q	Weight
HD-700 SERIES WITH LONG BASE PLATE																
HD-700	in	1.25	0.4995/0.4999	5.875	24	12.75	11	0.625	9.5	10	22.5	9.5	0.375	0.06	0.63	39 lb
	mm	31.8	12.687/12.692	149.2	609.6	323.9	279.4	15.9	241.3	254	571.5	241.3	9.5	1.6	15.9	17.6 kg
HD-710	in	1.25	0.4995/0.4999	5.875	26	13.59	11	0.625	9.5	10	24.5	9.5	0.375	N/A ^{b)}		45 lb
	mm	31.8	12.687/12.692	149.2	660.4	345.2	279.4	15.9	241.3	254	622.3	241.3	9.5	N/A ^{b)}		20.3 kg
HD-705	in	1.25	0.4995/0.4999	5.875	28	13.62	11	0.625	9.5	10	26.5	9.5	0.375	0.06	0.63	52 lb
	mm	31.8	12.687/12.692	149.2	711.2	346.0	279.4	15.9	241.3	254	673.1	241.3	9.5	1.6	15.9	23.5 kg
HD-715	in	1.25	0.4995/0.4999	5.875	30	14.29	11	0.625	9.5	10	28.5	9.5	0.375	N/A ^{b)}		59 lb
	mm	31.8	12.687/12.692	149.2	762.0	363.0	279.4	15.9	241.3	254	723.9	241.3	9.5	N/A ^{b)}		26.6 kg
HD-700 SERIES WITH SHORT BASE PLATE																
HD-700	in	1.25	0.4995/0.4999	5.875	11.34	0.09	11	0.625	9.5	10	9.84	9.84	0.375	0.06	0.63	30 lb
	mm	31.8	12.687/12.692	149.2	288.0	2.2	279.4	15.9	241.3	254	250.0	250	9.5	1.6	15.9	13.6 kg
HD-710	in	1.25	0.4995/0.4999	5.875	12.50	0.09	11	0.625	9.5	10	11.00	9.84	0.375	N/A ^{b)}		36 lb
	mm	31.8	12.687/12.692	149.2	317.5	2.2	279.4	15.9	241.3	254	279.5	250	9.5	N/A ^{b)}		16.3 kg
HD-705	in	1.25	0.4995/0.4999	5.875	14.45	0.09	11	0.625	9.5	10	12.95	9.84	0.375	0.06	0.63	43 lb
	mm	31.8	12.687/12.692	149.2	367.0	2.2	279.4	15.9	241.3	254	329.0	250	9.5	1.6	15.9	19.5 kg
HD-715	in	1.25	0.4995/0.4999	5.875	15.75	0.09	11	0.625	9.5	10	14.25	9.84	0.375	N/A ^{b)}		50 lb
	mm	31.8	12.687/12.692	149.2	400.0	2.2	279.4	15.9	241.3	254	362.0	250	9.5	N/A ^{b)}		22.7 kg

a) These dimensions represent the distance between mounting holes. There are four (4) mounting holes on each base plate.

b) Shaft Flats are not available on high speed models.

NOTE: 3D STEP files of most of our products are available on our website: www.magtrol.com ; other files are available on request.



HD SERIES

GENERAL INFORMATION

DIMENSIONS HD-800

HD-800 SERIES WITH LONG BASE PLATE

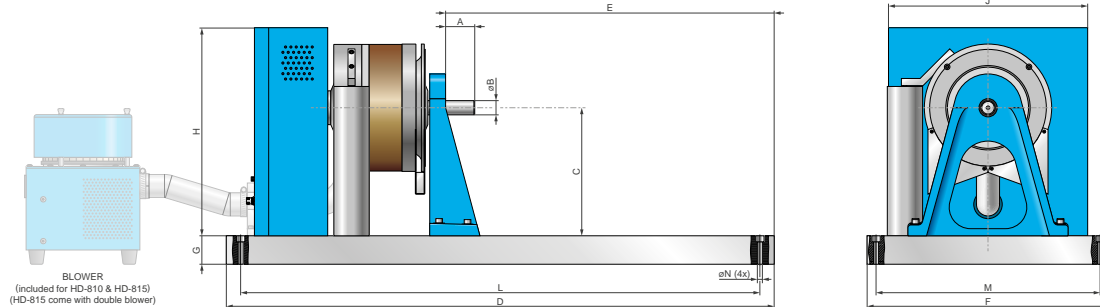

HD-800 SERIES WITH SHORT BASE PLATES

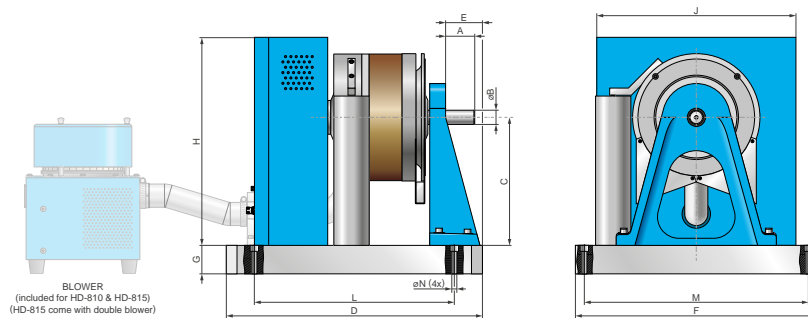

Fig. 5: HD-810 Dynamometer with short base plate and blower

NOTE: For detailed dimension drawings of dynamometers with the T-slot base plate option, visit Magtrol's Web site.

NOTE: Original dimensions are in English units. Dimensions converted to Metric units have been rounded and are for reference only.

MODEL	units	A	øB	C	D	E	F	G	H	J	L ^{a)}	M ^{a)}	øN	Weight
HD-800 SERIES WITH LONG BASE PLATE														
HD-800	in	2.13	0.9995/1.0000	9	38.5	23.81	17	2	14.6	14	36.5	15	0.53	237.0 lb
	mm	54	25.387/25.400	228.6	978	605	432	50.8	371	356	927	381	13.5	107.2 kg
HD-810	in	2.05	0.9995/1.0000	9	38.5	23.09	17	2	14.6	14	36.5	15	0.53	233.0 lb
	mm	52	25.387/25.400	228.6	978	587	432	50.8	371	356	927	381	13.5	105.3 kg
HD-805	in	2.13	0.9995/1.0000	9	38.5	20.57	17	2	14.6	14	36.5	15	0.54	287.0 lb
	mm	54	25.387/25.400	228.6	978	522	432	50.8	371	356	927	381	13.7	129.7 kg
HD-815	in	2.12	0.9995/1.0000	9	38.5	18.19	17	2	14.6	14	36.5	15	0.54	288.0 lb
	mm	54	25.387/25.400	228.6	978	462	432	50.8	371	356	927	381	13.7	130.1 kg
HD-800 SERIES WITH SHORT BASE PLATE														
HD-800	in	2.13	0.9995/1.0000	9	17.25	2.56	17	2	14.6	14	13.78	15.75	0.35	168.0 lb
	mm	54	25.387/25.400	228.6	438	65	432	50.8	371	356	350	400	9	76.2 kg
HD-810	in	2.05	0.9995/1.0000	9	18.00	2.59	17	2	14.6	14	14.06	15.75	0.35	164.0 lb
	mm	52	25.387/25.400	228.6	457	66	432	50.8	371	356	357	400	9	74.4 kg
HD-805	in	2.13	0.9995/1.0000	9	20.50	2.57	17	2	14.6	14	15.75	15.75	0.35	228.0 lb
	mm	54	25.387/25.400	228.6	520	65	432	50.8	371	356	400	400	9	103.4 kg
HD-815	in	2.12	0.9995/1.0000	9	23.00	2.59	17	2	14.6	14	19.09	15.75	0.35	236.0 lb
	mm	54	25.387/25.400	228.6	584	66	432	50.8	371	356	485	400	9	107.0 kg

a) These dimensions represent the distance between mounting holes. There are four (4) mounting holes on each base plate.

NOTE: 3D STEP files of most of our products are available on our website: www.magtrol.com ; other files are available on request.



HD SERIES

DIMENSIONS HD-825

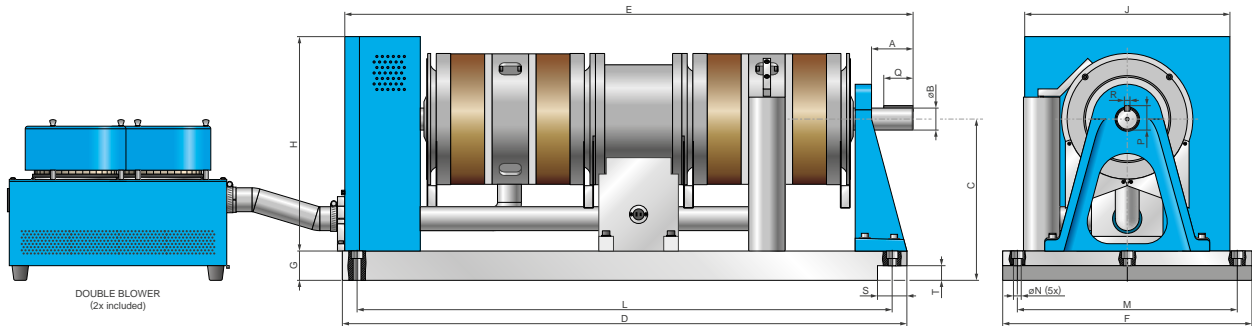

An HD-825 Dynamometer with long base plate is available if ordered with the accompanying dynamometer table (TAB 0825L). Contact Magtrol for details.

MODEL	units	A	øB	C	D	E	F	G	H	J	L ^{a)}	M ^{a)}	øN	P	Q	R	S	T	Weight
HD-825	in	2.83	1.4995 1.5000	11	38.5	38.93	17	2	16.6	14	36.5	15	0.54	1.287	2	0.376	2	1	400.0 lb
	mm	72	38.087 38.100	279.4	978	989	432	50.8	422	356	927	381	13.7	32.69	50.8	9.53	50.8	25.4	181.4 kg

a) These dimensions represent the distance between mounting holes. There are four (4) mounting holes on each base plate.

BLOWERS

BLOWER POWER

MODEL	VOLTAGE	VA	MODEL	VOLTAGE	VA
BL-001	120 V	600	BL-002	120 V	1000
BL-001A	240 V	500	BL-002A	240 V	

- Models HD-710, HD-715 & HD-810 include the BL-001 blower.
- Models HD-815 include the BL-002 blower.
- Model HD-825 uses two BL-002 blowers for cooling its two brake sets.

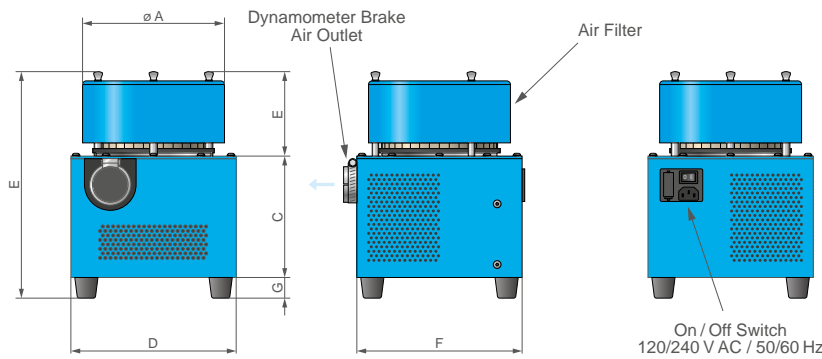

Allow approximately 6 in to 8 in (152 mm to 203 mm) between rear of dynamometer base plate and blower for connection hardware. Required hardware is supplied with the dynamometer.

BL-002 Blower has two filter elements.

MODEL	units	øA	B	C	D	E	F	G	Weight
BL-001	mm	178	279	254	203	102	203	25	3.9 kg
	in	7	11	10	8	4	8	1	8.5 lb
BL-002	mm	178	279	254	381	102	308	25	8.1 kg
	in	7	11	10	15	4	12	1	18 lb

NOTE: 3D STEP files of most of our products are available on our website: www.magtrol.com ; other files are available on request.



HD SERIES

GENERAL INFORMATION

POWER ABSORPTION CURVES

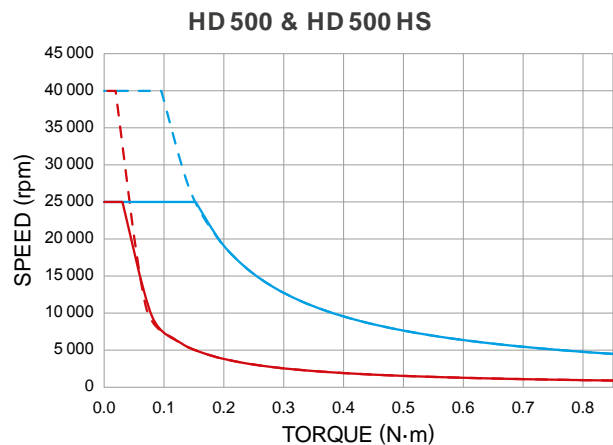
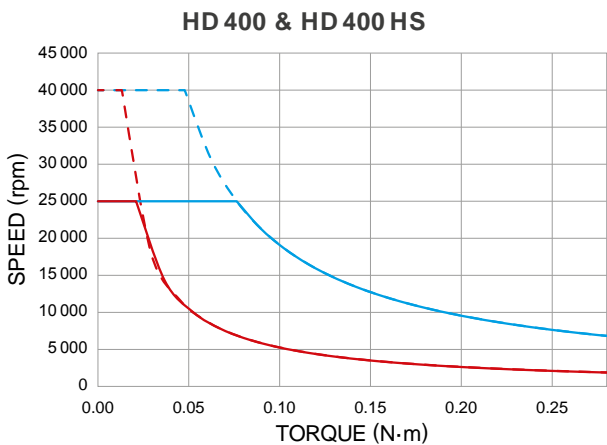
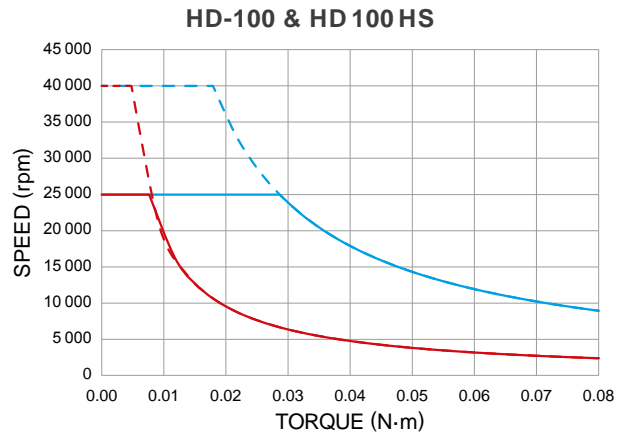
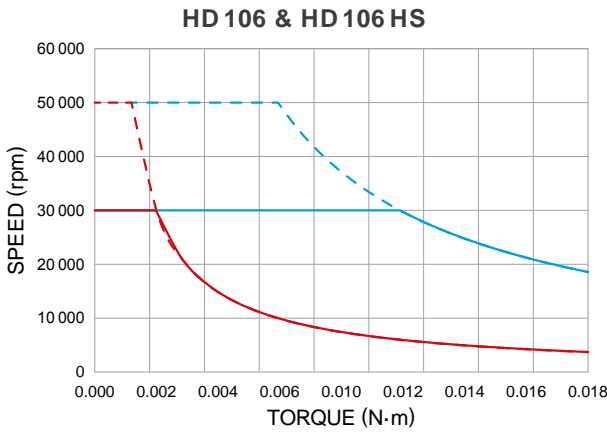
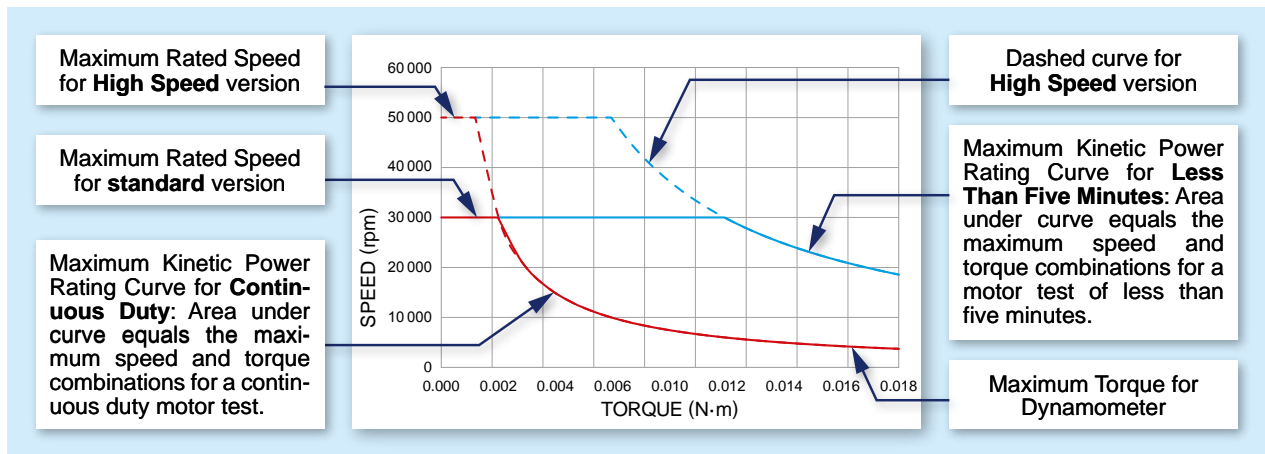

The power absorption curves represent the maximum power (heat) that the dynamometer can dissipate over time.



HD SERIE

GENERAL INFORMATION

POWER ABSORPTION CURVES

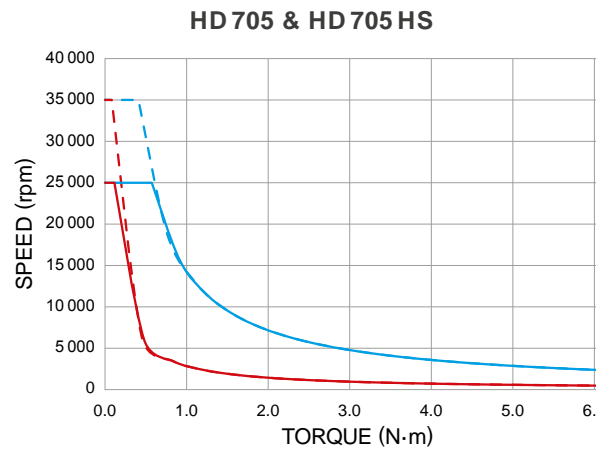
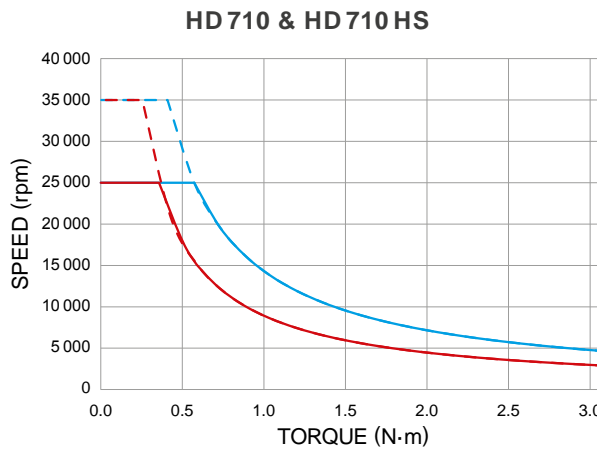
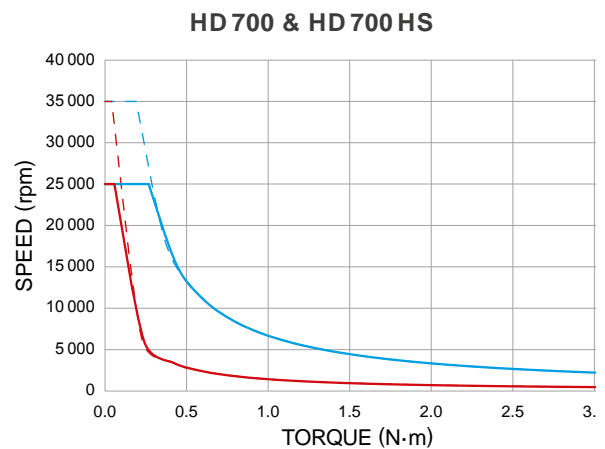
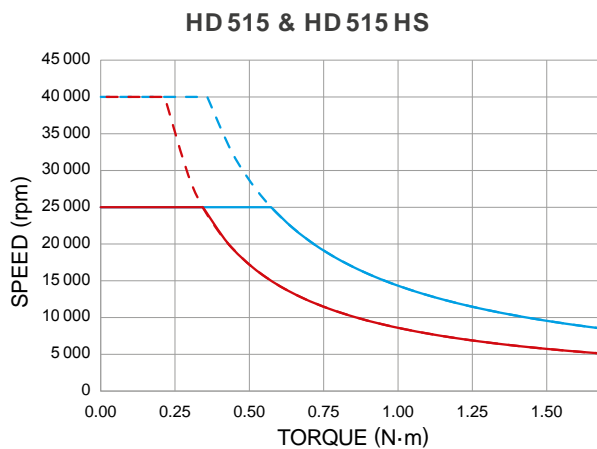
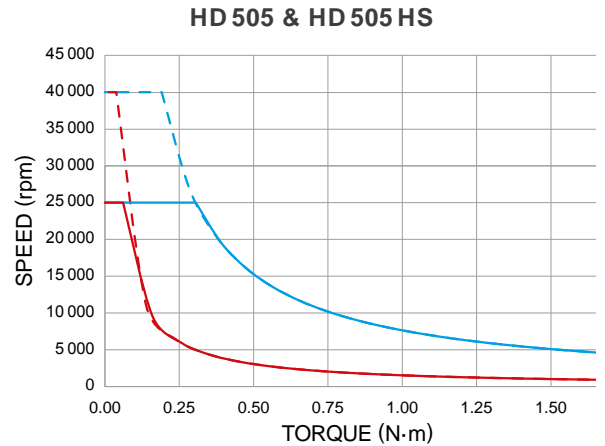
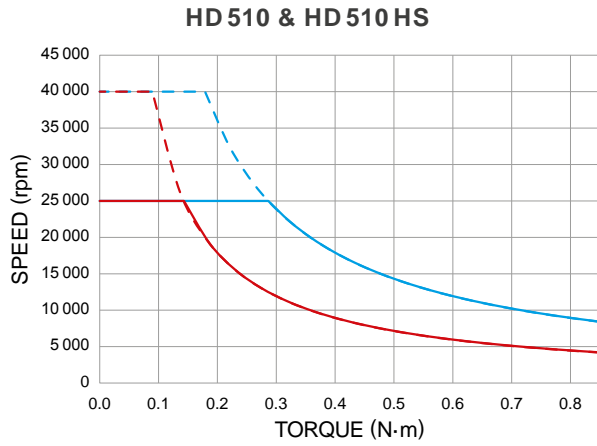

The power absorption curves represent the maximum power (heat) that the dynamometer can dissipate over time



HD SERIES

GENERAL INFORMATION

POWER ABSORPTION CURVES

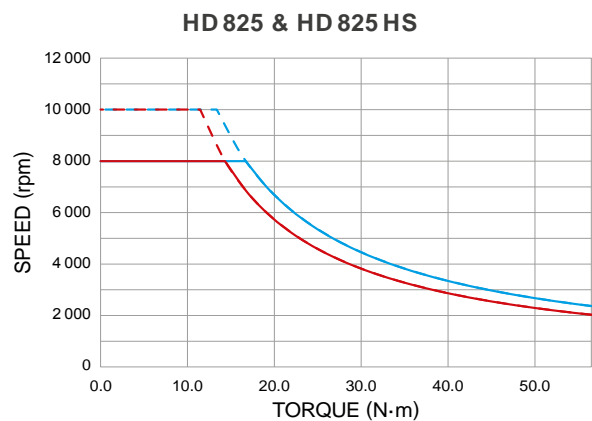
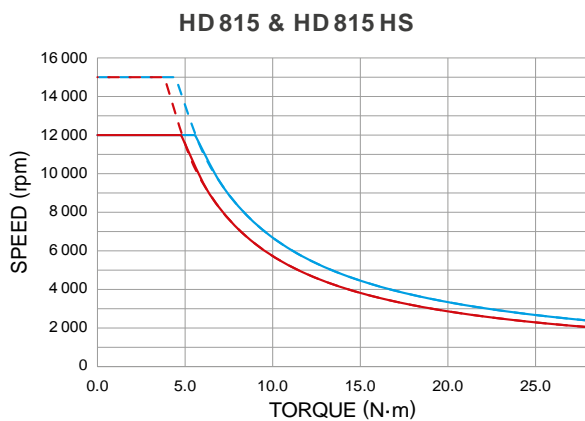
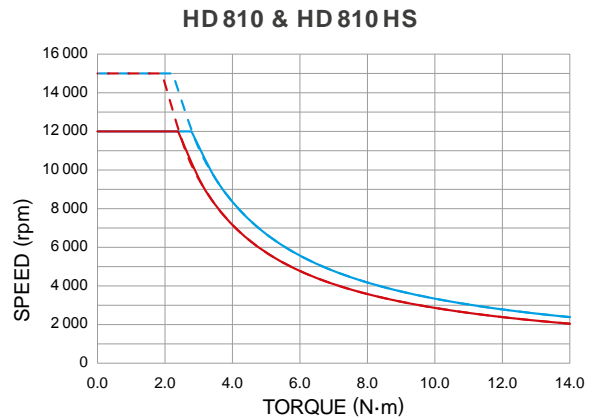
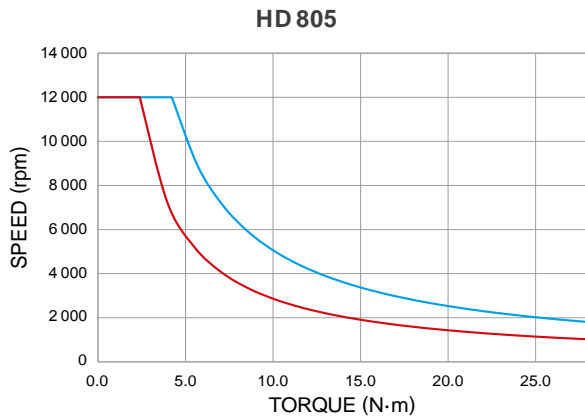
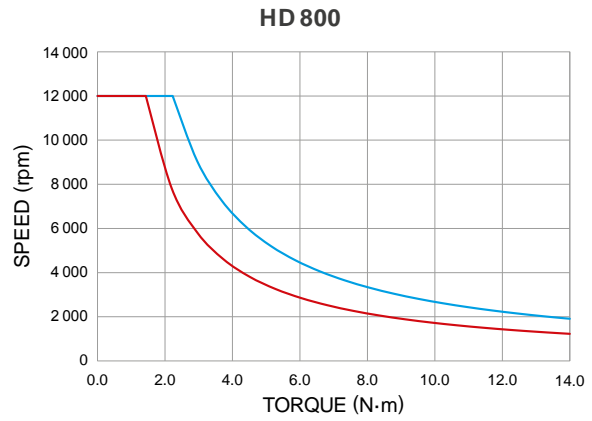
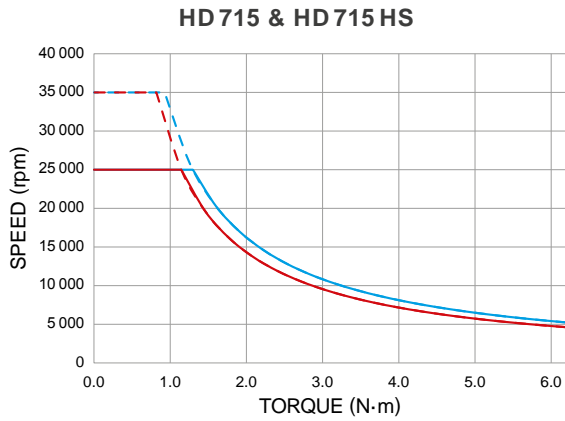

The power absorption curves represent the maximum power (heat) that the dynamometer can dissipate over time.



HD SERIES

GENERAL INFORMATION

CUSTOM MOTOR TEST SYSTEM

HD Series Hysteresis Dynamometers can be incorporated into a Customized Motor Test System (CMTS).

These PC based, turn-key systems are custom designed and built to meet specific user requirements.

Various devices such as dynamometer controllers, power analyzers or other customized devices can be easily integrated into a 19" rack system (in an external cabinet or directly in the table).

These systems integrate specific software (such as M-TEST) to facilitate the measurement process.

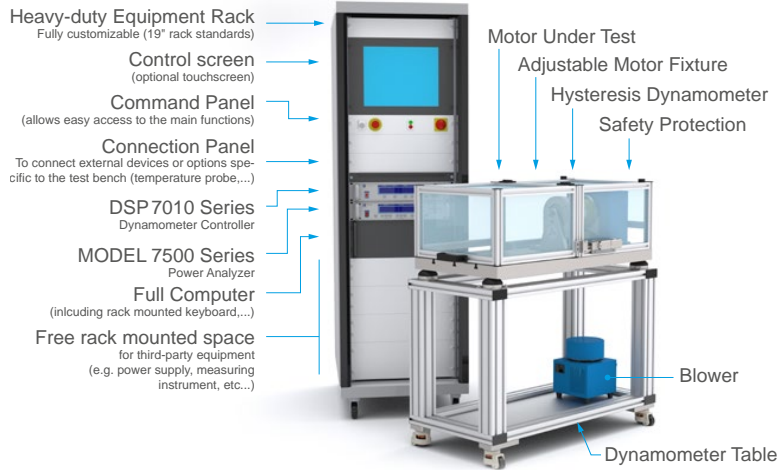

DYNAMOMETER OPTIONS

ENCODER OPTIONS FOR LOW SPEED TESTING

For low speed motors, such as gear motors with maximum speeds of less than 200 rpm, Magtrol offers additional encoder options that allow for increased resolution of the speed signal.

T-SLOT BASE PLATE

To accommodate Magtrol AMF-3 Adjustable Motor Fixtures, a grooved base plate with three M12 T-slots, one centered and two 250 mm apart, is available on all HD-8XX series dynamometers.

MECHANICAL CUSTOMISATIONS

Magtrol is highly experienced and qualified in the customization of its products. We can provide customized base plates, riser blocks and shaft modifications. Our specialized salesmen and technicians are at your service to help you find the best configuration for your project.



ORDERING INFORMATION

MODEL NUMBER	HD-	---	- 5C	-	- 0 ^{a)}	-	-	-
100-825 : Hysteresis Dynamometers								
0 : AC power not applicable								
1 : 120 VAC								
2 : 240 VAC								
0 : Long base plate ^{b)}								
1 : Short base plate								
2 : Long base with T-slots (HD-8XX Series only)								
0 : 60 PPR speed encoder (standard & HS) ^{c)}								
3 : 60 + 600 PPR speed encoder ^{c)}								
4 : 60 + 6000 PPR speed encoder ^{c)}								
0 : Standard version								
H : High Speed (not available on HD-800 & HD-805)								

- a) In case of special design the 4 last digits will be specific; please contact our sales representative
- b) Please contact our sales representative regarding long base plate
- c) PPR means Pulse Per Revolution

Example: HD Series Dynamometer, model 106, supply in 240 VAC, short base plate, 60-PPR encoder and standard version would be ordered as follows: **HD-106-5C2-0100**
 HD Series Dynamometer, model 805, supply in 120 VAC, long base plate with T-slot, 6000-PPR encoder and high speed version would be ordered as follows: **HD-805-5C1-024H**

CABLE ASSEMBLY

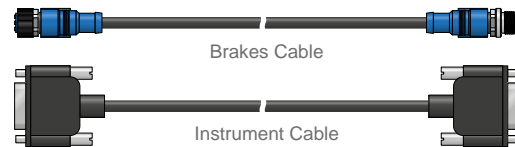

ORDERING NUMBER	88M	---	-	---
367 : Brake Cable				
368 : Instrument Cable				
0150 : Cable length 1.5m ^{a)}				
0500 : Cable length 5m ^{a)}				

a) Other length available on request



HD SERIES

SYSTEM OPTIONS AND ACCESSORIES

DSP 7010 - DYNAMOMETER CONTROLLERS

Magtrol's MODEL DSP7010 Series Dynamometer Controller employs state-of-the-art Digital Signal Processing Technology to provide superior motor testing capabilities. Designed for use with any Magtrol Hysteresis, Eddy-Current or Powder Dynamometer, Magtrol In-Line Torque Transducer or auxiliary instrumentation, the DSP 7010 can provide complete PC control via the USB or IEEE-488 interface. With up to 500 readings per second, the DSP7010 is ideally suited for both the test lab and the production line.



Fig. 7: DSP 7011 | Programmable Dynamometer Controllers

MODEL 7500 - POWER ANALYZERS

The Magtrol MODEL7500 Power Analyzer is an easy-to-use instrument ideal for numerous power measurement applications. From DC to 80kHz, the MODEL 7500 measures volts, amps, watts, volt-amps, frequency, crest factor, Vpeak, Apeak and power factor in one convenient display. They may be used either as stand-alone instruments or in conjunction with any Magtrol Hysteresis, Eddy-Current or Powder Brake Dynamometer; any Magtrol Dynamometer Controller and M-TEST Software for more demanding motor test applications.



Fig. 9: MODEL 7510 | Power Analyzers

WB & PB SERIES - DYNAMOMETER



Fig. 8: 1 PB 115 | Powder Dynamometer

The WB Series (eddy current) and PB Series (magnetic powder) dynamometers are particularly suitable for demanding applications requiring low (PB) to high (WB up to 65000 rpm) speeds. The PB brakes will develop their nominal torque at standstill, while the WB

brakes develop a braking torque proportional to the speed and their maximum torque is reached at nominal speed. The brake is cooled by water circulating in the stator. As a result, these dynamometers are able to dissipate high continuous loads (up to 140kW). The WB and PB dynamometers incorporate a torque measuring system which has an accuracy of $\pm 0.3\%$ to $\pm 0.5\%$ at full scale.

TAB SERIES - DYNAMOMETER TABLES

Test from a stationary position or move a dynamometer to alternate testing stations with ease with Magtrol's Dynamometer Table. The stand is designed from lightweight aluminum with casters for smooth mobility, and is sturdy enough to support even the heaviest of Magtrol dynamometers. The design can be retrofitted to any Magtrol dynamometer and is easily reconfigured for added versatility.

AMF SERIES - MOTOR FIXTURES

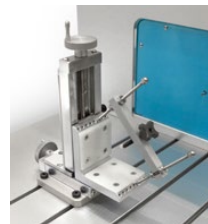

Positioning and alignment have a great influence on the measured parameters (friction torque). MAGTROL strongly recommends a support specifically dedicated to the products to be tested to ensure the best positioning tolerances in X-Y, and its repeatability.

Alternatively, Magtrol AMF Series (Adjustable Motor Fixtures) can be used. These extremely versatile fixtures can accommodate motors up to 101 mm (4") in diameter. It enables easy motor centering during testing, but does not have centering references.



Fig. 10: TAB Series | Dynamometer Tables

©2023 MAGTROL | Due to continual product development, Magtrol reserves the right to modify specifications without forewarning.

Page 14 / 14

DATASHEET

www.magtrol.com

MAGTROL INC
70 Gardenville Parkway
Buffalo NY 14224 | USA

phone +1 716 668 5555
fax +1 716 668 8705
e-mail magtrol@magtrol.com

MAGTROL SA
Route de Montena 77
1728 Rossens | Switzerland

phone +41 26 407 30 00
fax +41 26 407 30 01
e-mail magtrol@magtrol.ch

Offices in: Germany
France - China - India
Worldwide Distribution Network



HD SERIES - US 06/2023



ED SERIES

ED SERIES ENGINE DYNAMOMETERS

MAGTROL offers 3 types of dynamometer brakes to absorb load: Hysteresis (**HD Series**), Eddy-Current (**WB Series**) and Magnetic Powder (**PB Series**). Each type of Dynamometer has advantages and limitations and choosing the correct one will depend largely on the type of testing to be performed. With over 50 standard models to choose from, Magtrol Sales professionals are readily available to assist in selecting the proper Dynamometer to meet your testing needs.

FEATURES

- Maximum Torque: 55 ... 250 lb·in (6.5 N·m ... 28 N·m)
- Hysteresis Braking System
- Motor Testing: from no load to locked rotor
- Standard Torque Units : SI (English & Metric available upon request)
- Accuracy: $\pm 0.25\%$ (full scale)
- Blower Cooled: to maximize heat dissipation
- Air Flow Sensor: for protection against overheating and operator error
- Specially Reinforced Load Cell: stainless steel pin at contact point prevents premature wear from excess vibration
- Larger Shaft: for additional strength
- Gusseted Pillow Blocks: for additional front and rear support



Fig. 1: ED-715 | Engine Dynamometer

DESCRIPTION

With Magtrol's Engine Dynamometers, high performance motor testing is available to manufacturers and users of small engines. Magtrol's Engine Dynamometers have been designed to address the severe, high vibration conditions inherent in internal combustion engine testing.

Magtrol's Engine Dynamometers are highly accurate ($\pm 0.25\%$ of full scale) and can be controlled either manually or via a PC based Controller. For a small engine test stand, Magtrol offers a full line of controllers, readouts and software.

As with all Magtrol Hysteresis Dynamometers, engine loading is provided by Magtrol's Hysteresis Brake, which provides: torque independent of speed, including full load at 0 rpm; excellent repeatability; frictionless torque with no wearing parts (other than bearings); and long operating life with low maintenance.

APPLICATIONS

The Engine Dynamometers are ideally suited for emissions testing as set forth in CARB and EPA Clean Air Regulations. The Dynamometers will offer superior performance on the production line, at incoming inspection or in the R&D lab.



ED SERIES

DYNAMOMETER SELECTION

Magtrol's Hysteresis Dynamometers cover a wide range of Torque, Speed and Mechanical Power ratings. To select the appropriate size Dynamometer for your motor testing needs, you will need to determine the **Maximum Torque, Speed and Power** applied to the Dynamometer.

MAXIMUM TORQUE

The Magtrol Hysteresis Absorption Dynamometer will develop braking torque at any speed point, including low speed and stall conditions ("0" rpm). It is important to consider all torque points that are to be tested, not only rated torque, but also locked rotor and breakdown torque. Dynamometer selection should initially be based on the maximum torque requirement, subject to determining the maximum power requirements.

MAXIMUM SPEED

This rating is to be considered independent of torque and power requirements, and is the maximum speed at which the Dynamometer can be safely run under free-run or lightly loaded conditions. It is not to be considered as the maximum speed at which full braking torque can be applied.

To safely dissipate heat and avoid Dynamometer failure, the maximum power rating is the most important consideration in selecting a Dynamometer.

MAXIMUM POWER RATINGS

These ratings represent the maximum capability of the Dynamometer Braking System to absorb and dissipate heat generated when applying a braking load to the motor under test. The power absorbed and the heat generated by the Dynamometer is a function of the Torque (**T**) applied to the motor under test, and the resulting Speed (**n**) of the motor. This is expressed in these Power (**P**) formulas:

$$\begin{aligned} \text{SI: } P [W] &= T [N \cdot m] \times n [\text{min}^{-1}] \times (1.047 \times 10^{-1}) \\ \text{English: } P [W] &= T [\text{lb} \cdot \text{in}] \times n [\text{rpm}] \times (1.183 \times 10^{-2}) \\ \text{Metric: } P [W] &= T [\text{kg} \cdot \text{cm}] \times n [\text{rpm}] \times (1.027 \times 10^{-2}) \end{aligned}$$

All of Magtrol's controllers, readouts and software calculate horsepower as defined by 1 [hp] = 550 [lb-ft/s].

Using this definition: $P [\text{hp}] = P [W] / 745.7$

The Dynamometer's ability to dissipate heat is a function of how long a load will be applied. For this reason, the maximum power ratings given are based on continuous operation under load, as well as a maximum of 5 minutes under load.

OPERATING PRINCIPLES

Magtrol Hysteresis Dynamometers absorb power with a unique Hysteresis Braking System which provides frictionless torque loading independent of shaft speed. The Hysteresis Brake provides torque by the use of two basic components - a reticulated pole structure and a specialty steel rotor/shaft assembly - fitted together but not in physical contact.

Until the pole structure is energized, the drag cup can spin freely on its shaft bearings. When a magnetizing force from the field coil is applied to the pole structure, the air gap becomes a flux field and the rotor is magnetically restrained, providing a braking action between the pole structure and rotor.

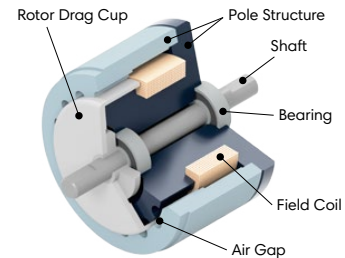

M-TEST - MOTOR TESTING SOFTWARE

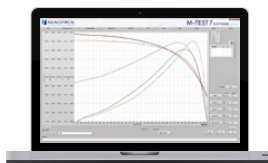

Magtrol's M-TEST Software is a state-of-the-art motor testing program for Windows®-based data acquisition. Used with a Magtrol Programmable Dynamometer Controller, Magtrol M-TEST Software provides the control of any Magtrol Dynamometer and runs test sequences in a manner best suited to the overall accuracy and efficiency of the Magtrol Motor Test System. The data that is generated by Magtrol's Motor Testing Software can be stored,

displayed and printed in tabular or graphic formats, and can be easily imported into a spreadsheet.

Written in LabVIEW™, M-TEST has the flexibility to test a majority of motor types in a variety of ways. Because of LabVIEW's versatility, obtaining data from other sources (e.g. thermocouples), controlling motor power and providing audio/visual indicators is relatively easy.

Magtrol's M-TEST Software is ideal for simulating loads, cycling the unit under test and motor ramping. Because it is easy to gather data and duplicate tests, the software is ideal for use in engineering labs. Tests can be programmed to run on their own and saved for future use allowing for valuable time savings in production testing and incoming/outgoing inspection.



ED SERIES

SYSTEM CONFIGURATIONS

OPEN LOOP SYSTEMS

Magtrol offers both open loop manual test systems and PC-based closed loop test systems. A typical open loop system will consist of a Dynamometer and a Magtrol DSP 7010 Dynamometer Controller. A Magtrol Single or Three-Phase Power Analyzer, which allows for the capturing of volts, amps, watts and power

factor, can be included as an option. An open loop system is often used for quick pass / fail testing on the production line or at incoming inspection. Magtrol's DSP 7010 Dynamometer Controller provides pass / fail testing as a standard feature.

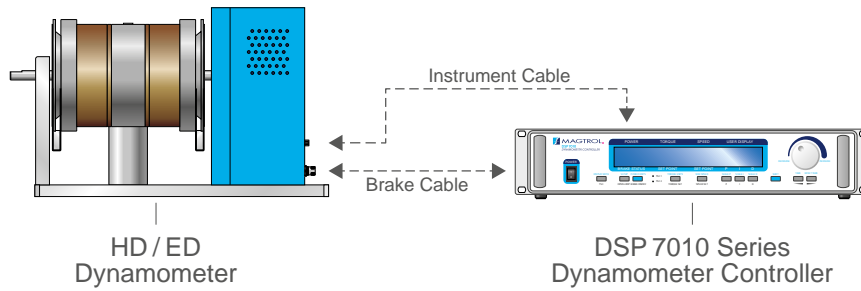

Fig.2: Dynamometer with DSP 7010 Dynamometer Controller

CLOSED LOOP SYSTEMS

In a closed loop motor test system, data is collected on a PC using Magtrol's M-TEST Software, DSP 7010 Programmable Dynamometer Controller, and requisite interface cards and cables. Magtrol's DSP 7010 Dynamometer Controllers compute and display mechanical power (in horsepower or watts) in

addition to torque and speed. A Single or Three Phase Power Analyzer, a required component in a test system measuring motor efficiency, can be integrated into this system as well as Magtrol's Temperature Testing Hardware.

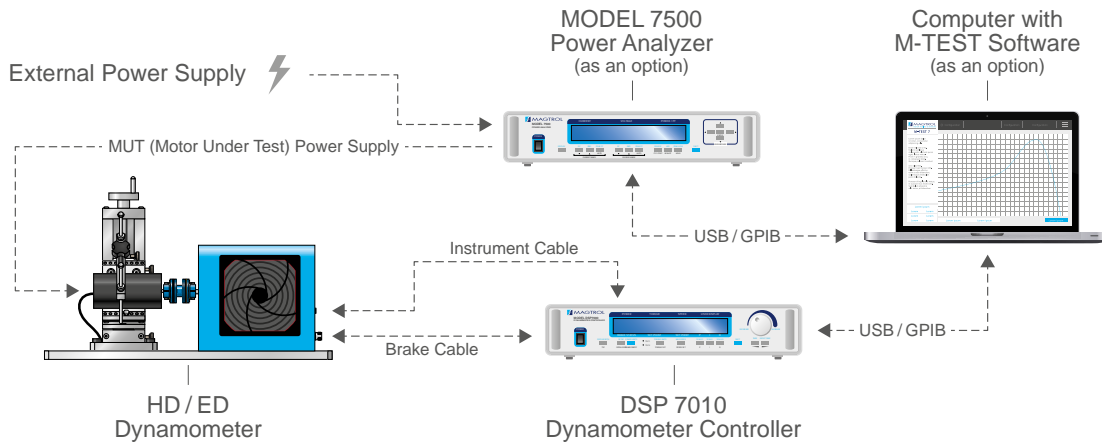

Fig.3: Dynamometer with MODEL 7500 Power Analyzer, DSP 7010 Dynamometer Controller and M-TEST Software



ED SERIES

SPECIFICATIONS

HYSTERESIS DYNAMOMETER RATINGS

MODELS	TORQUE MEASURE UNIT CODE ^{a)}	MAXIMUM TORQUE RANGE N·m	DRAG TORQUE DE-ENERGIZED AT 1000 rpm mN·m	NOMINAL INPUT INERTIA		MAX. POWER RATINGS		MAXIMUM SPEED rpm	BRAKE COOLING METHOD
				lb·ft·s ²	kg·m ²	5 min W	CONTINUOUS ^{c)} W		
ED-715	5C	6.2	35	1.27 × 10 ⁻³	1.72 × 10 ⁻³	3400	3000	25000	Blower ^{b)}
ED-815	5C	28.0	140	9.61 × 10 ⁻³	1.30 × 10 ⁻²	7000	6000	12000	Blower ^{b)}

- a) All -5C dynamometers are 5 Volt Output. Please, contact our sales representative for 6C (English units), 7C (Metric units) or 8C (SI units) specifications.
- b) Blower is included
- c) Operating at the continuous power rating for periods of up to 4 hours is acceptable. However, operating for extended periods at high temperatures will result in premature component and bearing failure. Limiting the length of the cycle and the component temperatures will guard against premature failure. Where continuous duty is desired for longer time intervals, component temperatures should be maintained less than 100°C. Monitoring the outside brake surface temperature is a sufficient reference.

ELECTRICAL POWER

MODELS	VOLTAGE	VA
ED-815-XC1	120V	130
ED-815-XC2	240V	

POWER ABSORPTION CURVES

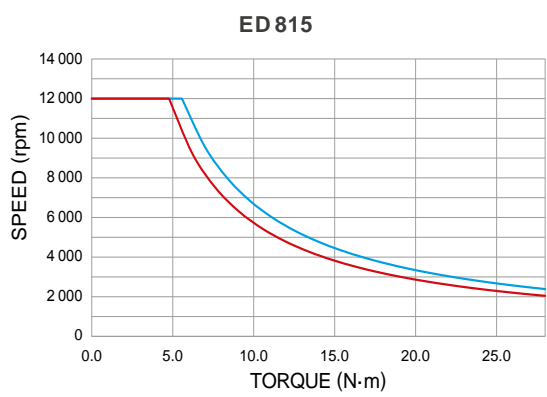
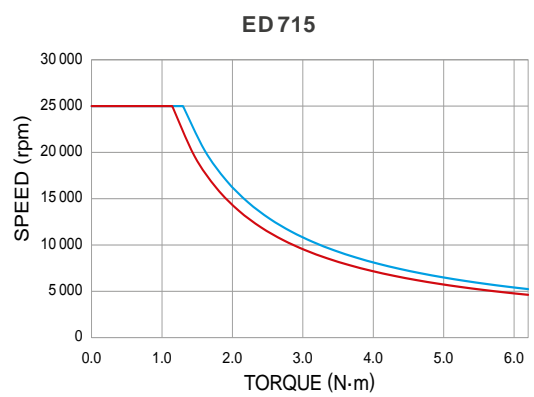
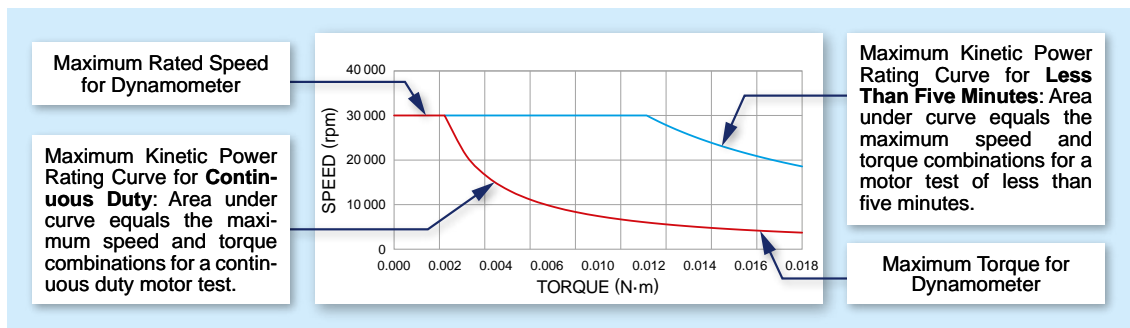



ED SERIES

DIMENSIONS

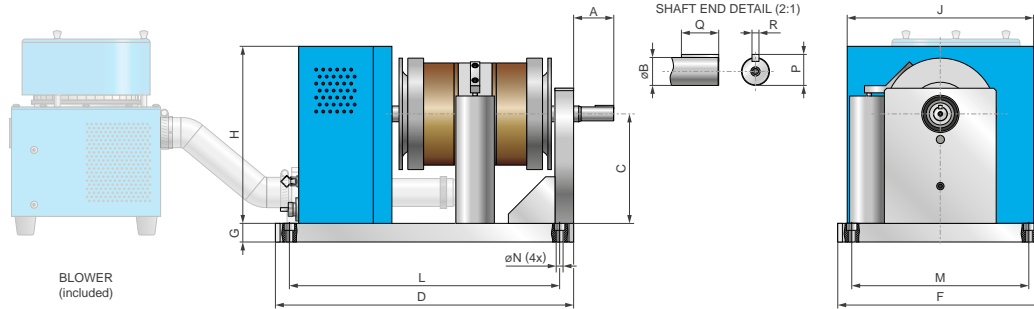

NOTE: Original dimensions are in English units. Dimensions converted to Metric units have been rounded and are for reference only.

MODEL	units	A	øB	C	D	E	F	G	H	L ^{a)}	M ^{a)}	øN	P	Q	R	Weight
ED-715	in	1.72	0.7490 0.7495	6.87	16.00	18.13	11.00	1.00	10.50	14.50	9.50	0.37	0.64	1.00	0.187	75 lb
	mm	43.7	19.025 19.037	174.5	406.4	460.5	279.4	25.4	266.7	368.3	241.3	9.4	16.35	25.4	4.83	34 kg
ED-815	in	3.02	1.4995 1.5000	11.00	23.00	23.27	17.00	2.00	16.63	20.80	15.00	5/8-11	1.287	2.00	0.375	285 lb
	mm	76.7	38.087 38.100	279.4	584.2	591.1	431.8	50.8	422.4	528.3	381.0	THD	32.7	50.8	9.53	129.3 kg

a) These dimensions represent the distance between mounting holes. There are four (4) mounting holes on each base plate.

BLOWERS

BLOWER POWER					
MODEL	VOLTAGE	VA	MODEL	VOLTAGE	VA
BL-001	120 V	600	BL-002	120 V	1 000
BL-001A	240 V	500	BL-002A	240 V	

- Models ED-715 include the BL-001 blower.
- Models ED-815 include the BL-002 blower.

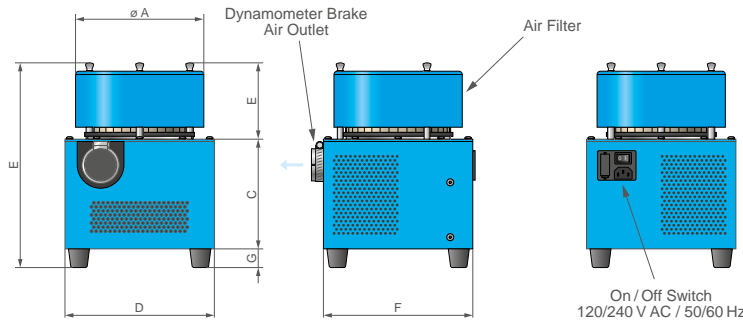

Allow approximately 6 in to 8 in (152 mm to 203 mm) between rear of dynamometer base plate and blower for connection hardware. Required hardware is supplied with the dynamometer.

BL-002 Blower has two filter elements.

MODEL	units	øA	B	C	D	E	F	G	Weight
BL-001	mm	178	279	254	203	102	203	25	3.9 kg
	in	7	11	10	8	4	8	1	8.5 lb
BL-002	mm	178	279	254	381	102	308	25	8.1 kg
	in	7	11	10	15	4	12	1	18 lb

NOTE: 3D STEP files of most of our products are available on our website: www.magtrol.com ; other files are available on request.



ED SERIES

CUSTOM MOTOR TEST SYSTEM

HD Series Hysteresis Dynamometers can be incorporated into a Customized Motor Test System (CMTS).

These PC based, turn-key systems are custom designed and built to meet specific user requirements.

Various devices such as dynamometer controllers, power analyzers or other customized devices can be easily integrated into a 19" rack system (in an external cabinet or directly in the table).

These systems integrate specific software (such as M-TEST) to facilitate the measurement process.

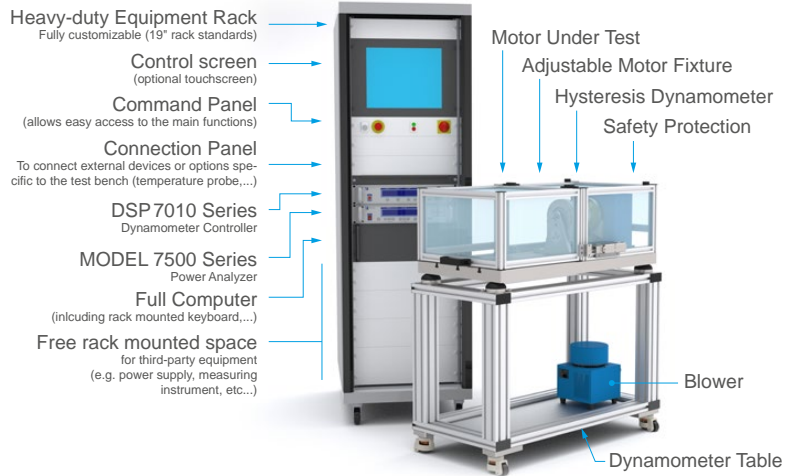

DYNAMOMETER OPTIONS

ENCODER OPTIONS FOR LOW SPEED TESTING

For low speed motors, such as gear motors with maximum speeds of less than 200 rpm, Magtrol offers additional encoder options that allow for increased resolution of the speed signal.

T-SLOT BASE PLATE

To accommodate Magtrol AMF-3 Adjustable Motor Fixtures, a grooved base plate with three M12 T-slots, one centered and two 250 mm apart, is available on all HD-8XX series dynamometers.

CUSTOM DYNAMOMETER

MECHANICAL MODIFICATIONS

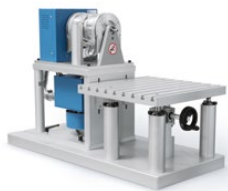

Fig. 4: Example of mechanical modifications

Magtrol is highly experienced and qualified in the customization of its products. We can provide customized base plates, riser blocks and shaft modifications. Our specialized salesmen and technicians are at your service to help you find the best configuration for your project. Thank you for contacting us, we will be glad to advise you.

ORDERING INFORMATION

MODEL NUMBER ED - - - - 5C - - 0 X - X^{a)}

715, 815 : Engine Dynamometers

- 1 : 120 VAC
- 2 : 240 VAC

- 0 : 60 PPR speed encoder (standard)^{b)}
- 3 : 60 + 600 PPR speed encoder^{b)}
- 4 : 60 + 6000 PPR speed encoder^{b)}

a) In case of special design the 4 last digits will be specific; please contact our sales representative
b) PPR means Pulse Per Revolution

Example: ED Series Dynamometer, Model 715, supply in 240VAC, 60PPR encoder would be ordered: ED-715-5C2-0X0X

CABLE ASSEMBLY

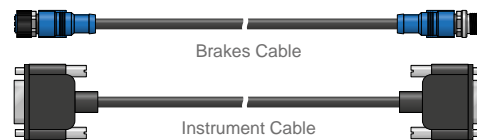

ORDERING NUMBER 88M - - - -

- 367 : Brake Cable
- 368 : Instrument Cable

- 0150 : Cable length 1.5 m^{a)}
- 0500 : Cable length 5 m^{a)}

a) Other length available on request



ED SERIES

SYSTEM OPTIONS AND ACCESSORIES

DSP 7010 - DYNAMOMETER CONTROLLERS

Magtrol's MODEL DSP7010 Series Dynamometer Controller employs state-of-the-art Digital Signal Processing Technology to provide superior motor testing capabilities. Designed for use with any Magtrol Hysteresis, Eddy-Current or Powder Dynamometer, Magtrol In-Line Torque Transducer or auxiliary instrumentation, the DSP 7010 can provide complete PC control via the USB or IEEE-488 interface. With up to 500 readings per second, the DSP 7010 is ideally suited for both the test lab and the production line.



Fig. 5: DSP 7011 | Programmable Dynamometer Controllers

MODEL 7500 - POWER ANALYZERS

The Magtrol MODEL7500 Power Analyzer is an easy-to-use instrument ideal for numerous power measurement applications. From DC to 80kHz, the MODEL 7500 measures volts, amps, watts, volt-amps, frequency, crest factor, Vpeak, Apeak and power factor in one convenient display. They may be used either as stand-alone instruments or in conjunction with any Magtrol Hysteresis, Eddy-Current or Powder Brake Dynamometer; any Magtrol Dynamometer Controller and M-TEST Software for more demanding motor test applications.



Fig. 7: MODEL 7510 | Power Analyzers

WB & PB SERIES - DYNAMOMETER

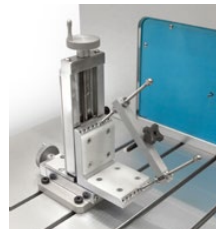

Fig. 6: 1PB115 | Powder Dynamometer

The WB Series (eddy current) and PB Series (magnetic powder) dynamometers are particularly suitable for demanding applications requiring low (PB) to high (WB up to 65000rpm) speeds. The PB brakes will develop their nominal torque at standstill, while the WB

brakes develop a braking torque proportional to the speed and their maximum torque is reached at nominal speed. The brake is cooled by water circulating in the stator. As a result, these dynamometers are able to dissipate high continuous loads (up to 140 kW). The WB and PB dynamometers incorporate a torque measuring system which has an accuracy of $\pm 0.3\%$ to $\pm 0.5\%$ at full scale.

AMF SERIES - MOTOR FIXTURES



Positioning and alignment have a great influence on the measured parameters (friction torque). MAGTROL strongly recommends a support specifically dedicated to the products to be tested to ensure the best positioning tolerances in X-Y, and its repeatability.

Alternatively, Magtrol AMF Series (Adjustable Motor Fixtures) can be used. These extremely versatile fixtures can accommodate motors up to 101 mm (4") in diameter. It enables easy motor centering during testing, but does not have centering references.



Fig. 8: TAB Series | Dynamometer Tables

TAB SERIES - DYNAMOMETER TABLES

Test from a stationary position or move a dynamometer to alternate testing stations with ease with Magtrol's Dynamometer Table. The stand is designed from lightweight aluminum with casters for smooth mobility, and is sturdy enough to support even the heaviest of Magtrol dynamometers. The design can be retrofitted to any Magtrol dynamometer and is easily reconfigured for added versatility.

©2023 MAGTROL | Due to continual product development, Magtrol reserves the right to modify specifications without forewarning.

Page 7 / 7

DATASHEET

www.magtrol.com

MAGTROL INC
70 Gardenville Parkway
Buffalo NY 14224 | USA

phone +1 716 668 5555
fax +1 716 668 8705
e-mail magtrol@magtrol.com

MAGTROL SA
Route de Montena 77
1728 Rossens | Switzerland

phone +41 26 407 30 00
fax +41 26 407 30 01
e-mail magtrol@magtrol.ch

Offices in: Germany
France - China - India
Worldwide Distribution Network



ED SERIES - US 06/2023

2. Inputs/Outputs

2.1 REAR PANEL

The rear panel provides connectors and receptacles for connecting to appropriate equipment.

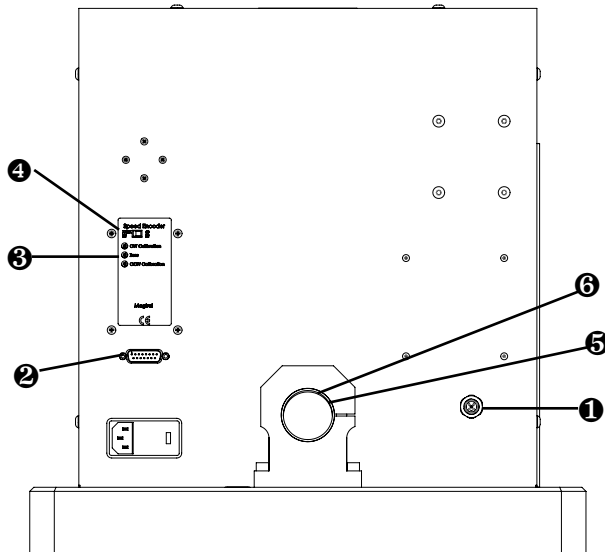

S

Figure 2-1 Rear Panel

2.2 REAR PANEL INPUTS AND OUTPUTS

- 1** DYNAMOMETER BRAKE INPUT Connect dynamometer brake cable here.

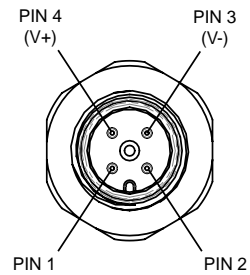

Figure 2-2 Dynamometer Brake Input

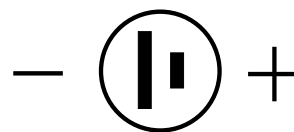
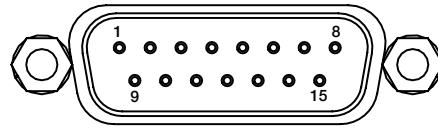

Figure 2-3 Prior to 2020 Dynamometer Brake Input

2 DYNAMOMETER CONNECTOR

Connect dynamometer signal cable here.



D-SUB 15 PIN CONNECTOR

- | | |
|-------------------|-------------------|
| 1. FLOW/CLUTCH | 8. N/C |
| 2. TACH B | 9. +5 VDC COMMON |
| 3. +24 VDC | 10. DP A |
| 4. ±24 VDC COMMON | 11. TACH A |
| 5. ±24 VDC COMMON | 12. INDEX |
| 6. -24 VDC | 13. DP B |
| 7. +5 VDC | 14. TORQUE COMMON |
| | 15. TORQUE SIGNAL |

Figure 2-4 Dynamometer Connector

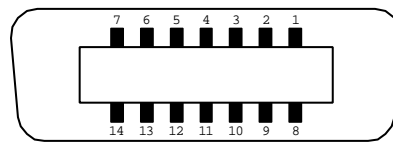

- | | |
|-----------------|-------------------|
| 1. FLOW /CLUTCH | 8. +5.0 VDC COM |
| 2. TACH .B | 9. D P .A |
| 3. +24 VDC | 10. TACH .A |
| 4. +24 VDC COM | 11. INDEX |
| 5. -24 VDC COM | 12. D P .B |
| 6. -24 VDC | 13. TORQUE COMMON |
| 7. +5.0 VDC | 14. TORQUE SIGNAL |

Figure 2-5 Prior to 2020 Dynamometer Connector

3 CALIBRATION POTENTIOMETER

Adjust clockwise (CW), zero and counterclockwise (CCW) calibration here. See Chapter 6 – Calibration.

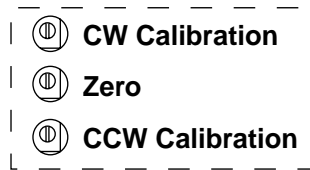

Figure 2-6 Calibration Potentiometers

4 ENCODER SWITCH

Optional feature switches between a 60 and 600-PPR encoder or a 60 and 6000-PPR encoder.

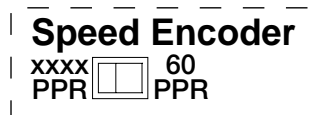

Figure 2-7 Speed Encoder Switch

5 BLOWER INPUT

Connect blower tube here. For HD-710, HD-715, HD-810, HD-815, HD-825, ED-715 and ED-815 Dynamometers only.



WARNING! DUE TO THE NOISE LEVELS OF THE BLOWERS, HEARING PROTECTION MUST BE WORN DURING OPERATION.

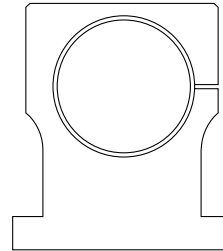

Figure 2–8 Blower Input

6 COMPRESSED AIR INPUT

Connect compressed shop air line here. For HD-510, HD-515, HD-800 and HD-805 Dynamometers only.

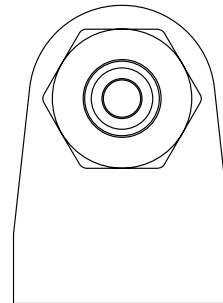

Figure 2–9 Compressed Air Input

3. Installation/Configuration

3.1 REMOVAL OF THE LOAD CELL SHIPPING/RESTRAINING BOLT

Within the dynamometer enclosure there is a load cell shipping/restraining bolt that must be removed before dynamometer operation. The bolts are identified with red heads. Refer to the diagrams below for the bolt location on your model.



Note: Retain the shipping/restraining bolt for future use when moving or shipping your Magtrol Dynamometer.

3.1.1 HD-100 AND HD-106

The shipping screw is located on the underside of the baseplate. The screw is painted red, and uses a slotted drive. Please refer to the dynamometer installation drawing (downloadable from the specifications tab on the product page, see www.magtrol.com) for further indication of the screw location.

If reinstalling the shipping screw for transportation on the HD-100 or HD-106, monitor the torque while tightening the shipping screw. Tighten the screw until the torque reading is approximately 110% of full-scale for the dynamometer.

3.1.2 HD-400 AND HD-5XX SERIES

The shipping/restraining bolt is located on the front side of the HD-400 and HD-5XX Series Hysteresis Dynamometers as shown in Figure 3-1.

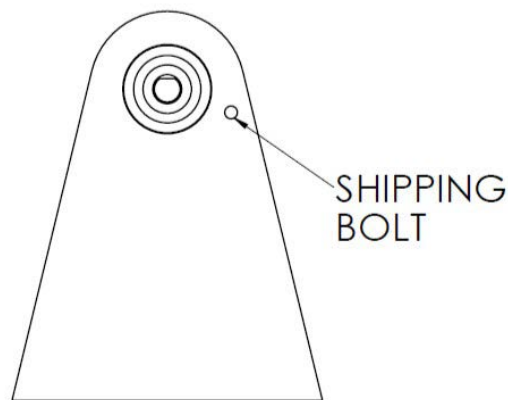

Figure 3-1 HD-400 and HD-5XX Series Shipping/Restraining Bolt Location

3.1.3 HD-7XX SERIES

The shipping/restraining bolt is located on the front side of the HD-7XX Series Hysteresis Dynamometers as shown in Figure 3–2.

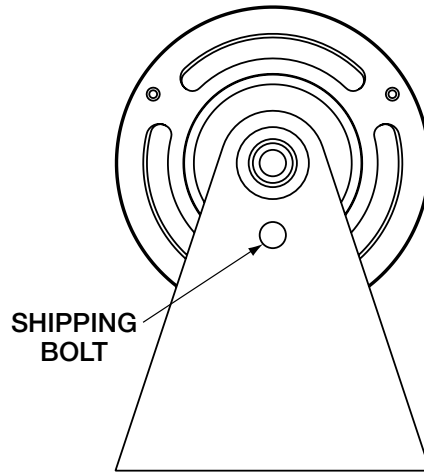

Figure 3–2 HD-7XX Series Shipping/Restraining Bolt Location

3.1.4 HD-8XX SERIES

There is no shipping/restraining bolt on an HD-8XX Series Hysteresis Dynamometer.

3.1.5 ED-715

The shipping/restraining bolt is located on the front side of the ED-715 dynamometer as shown in Figure 3–3.

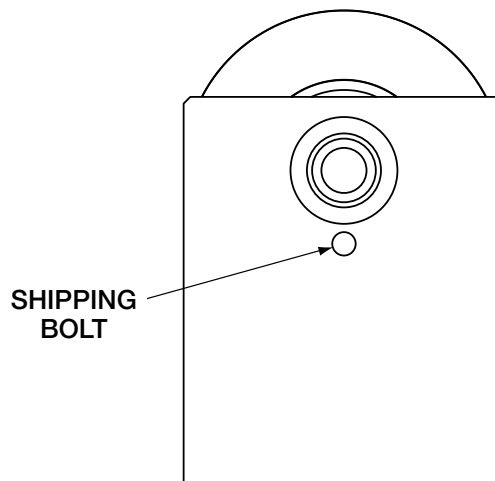

Figure 3–3 ED-715 Shipping/Restraining Bolt Location

3.1.6 ED-815

There is no shipping/restraining bolt on an ED-815 dynamometer.

SETUP

3.2 EARTH GROUND

Before proceeding any further, the dynamometer must be connected to earth ground. The earth ground is located on the top of the dynamometer as indicated in the following diagrams by the earth ground symbol.

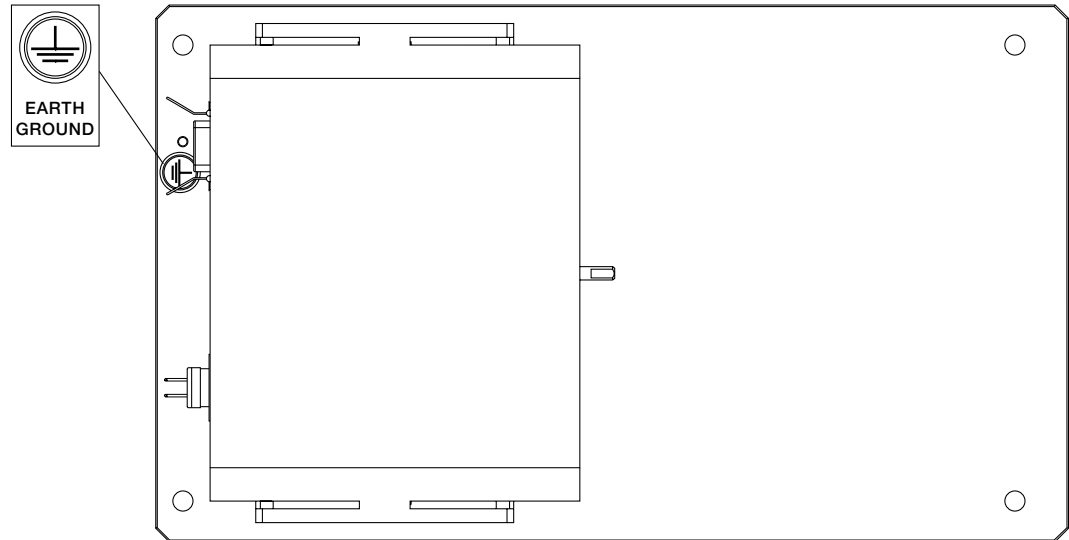

Figure 3-4 HD 100-5XX Series Top View

The following diagram is to be referenced for all HD-7XX Series, HD-8XX series and ED dynamometers.

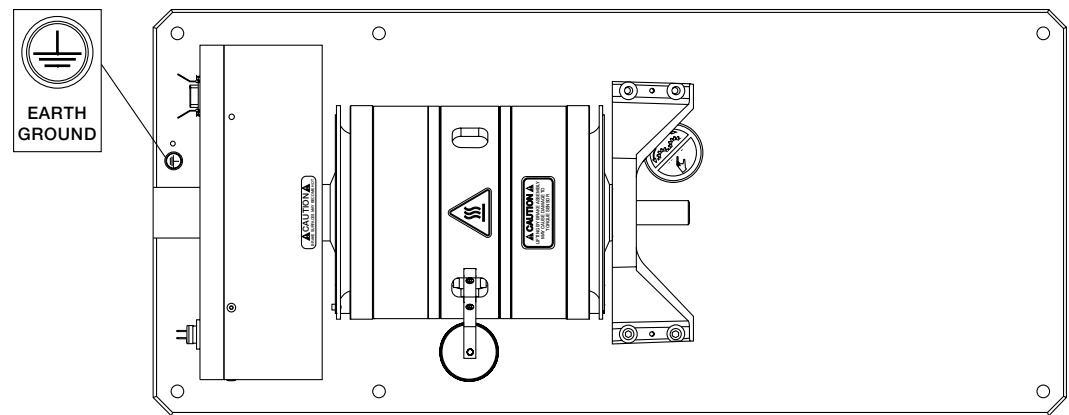

Figure 3-5 HD-8XX Series Top View

SETUP

3.3 SYSTEM CONFIGURATIONS

After the load cell shipping/restraining bolt has been removed and the dynamometer has been earth grounded, the unit is ready for connection to the appropriate readout instrument and power supply.

3.3.1 PC-BASED TEST SYSTEMS

In a PC-based motor test system, data is collected on a personal computer using Magtrol’s M-TEST Software, a DSP7010 Series Dynamometer Controller and requisite interface cards and cables.



Note: Magtrol’s Single or Three-Phase Power Analyzer can be integrated into this system as well as Magtrol’s Temperature Testing Hardware and Software.

The following diagrams illustrate the required cable sets and connections for a PC-based test system setup.

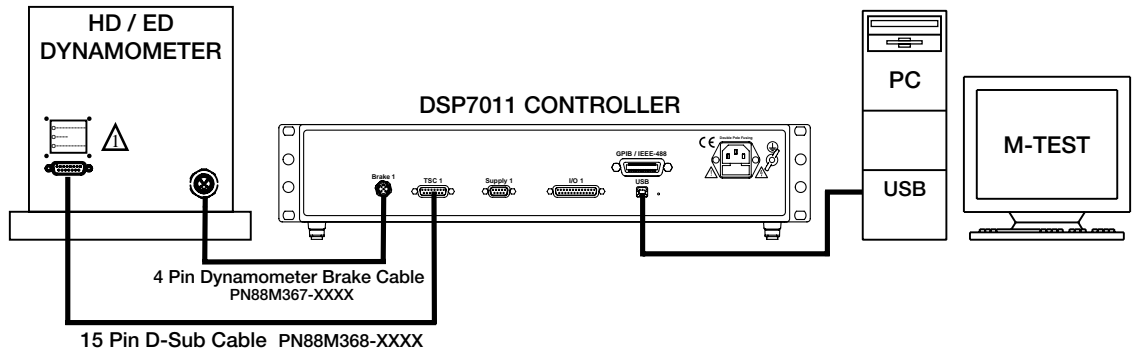

Figure 3-6 Dynamometer with DSP7011 Controller and M-TEST Software

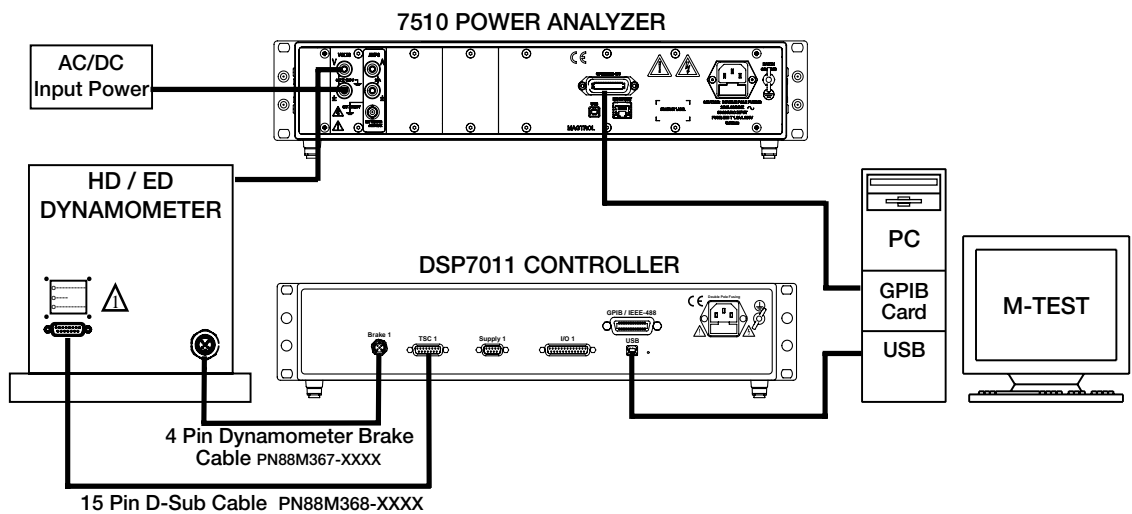

Figure 3-7 Dynamometer with 7510 Power Analyzer, DSP7011 Controller and M-TEST Software

SETUP

3.3.2 AIR COOLING

Magtrol’s HD-510/515/710/715, ED-715 and any 8XX Series Dynamometer are all internally ported for compressed air or blower cooling and may be integrated with a manual or PC-based test setup in order to provide air cooling of the dynamometer brake. An air flow sensor has been added to these dynamometers to protect against operator error. With the air flow sensor, the dynamometer comes equipped with a pressure sensor ported into the cooling airway. The sensor, when used in combination with Magtrol’s DSP7010 Series Dynamometer Controller, prevents the dynamometer brake from being energized until the blower or air supply has been turned on.

When the air supply to the dynamometer is turned on, the pressure sensor closes an electrical contact. Two wires from the sensor run internally to the dynamometer and attach to the torque amplification board. One of the wires from the sensor is then passed directly to the back panel connector (14-pin connector, pin 1). The other wire is tied on the board to +5 VDC COM (14-pin connector, pin 8).

When used with the DSP7010, pin 1 is internally pulled high with a resistance to 5 volts. If not using a Magtrol controller, it is assumed the user will pull pin 1 to the 5 volts supplied to the amplifier board (pin 7) with a 1 K to 10 K resistor.

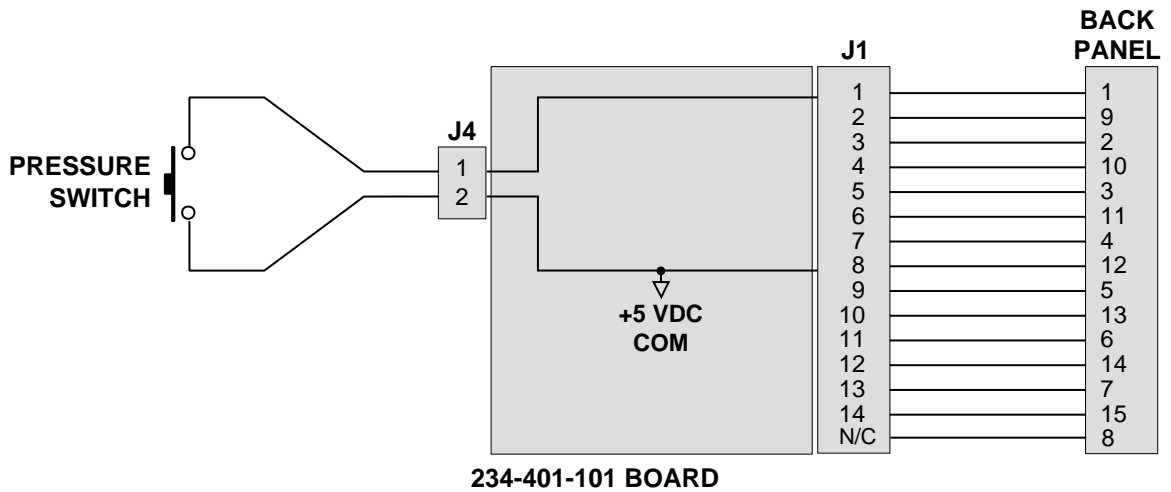

Figure 3–8 Air Flow Sensor Schematic

SETUP

3.3.2.1 Blower Setup

If an HD-710, HD-715, HD-810, HD-815, ED-715 or ED-815 dynamometer is being used, a blower input is integrated into the unit.

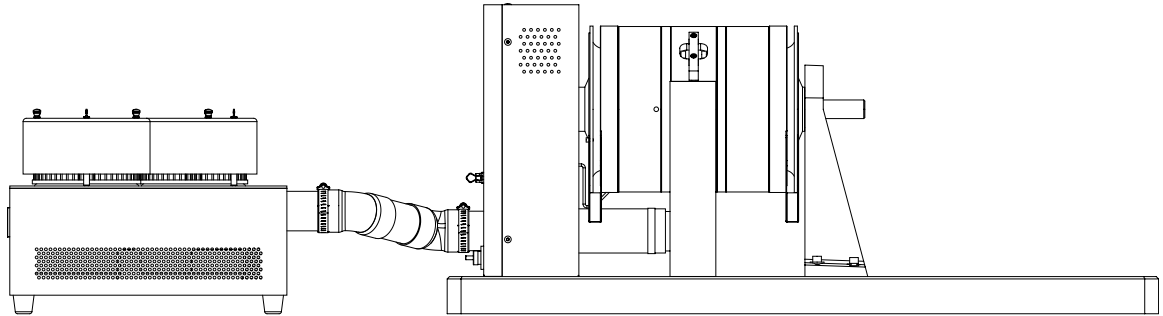

Figure 3–9 Dynamometer with Blower Connection

For more information, see Section 4.1.3.2.2 – Blower.



WARNING! DUE TO THE NOISE LEVELS OF THE BLOWERS, HEARING PROTECTION MUST BE WORN DURING OPERATION.

3.3.2.2 Compressed Air Setup

If a Model 510, 515, 800 or 805 dynamometer is being used, a compressed air input is integrated into the unit. The connection is illustrated in the following diagram.

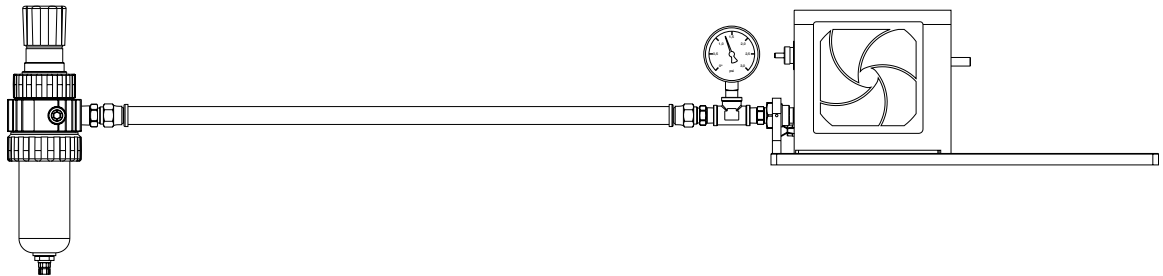

Figure 3–10 Dynamometer with Compressed Air Connection

For more information, see Section 4.1.3.2.1 – Compressed Air.

SETUP

4. Testing

4.1 TESTING CONSIDERATIONS

A number of factors must be taken into consideration before running a test including safety, accuracy, power dissipation, fixturing, couplings, windage, friction, vibration, cogging, eddy currents and temperature rise. The following sections describe these factors, and their effects, in further detail.

4.1.1 SAFETY



For general safety considerations, please follow these few common-sense rules:

- Be sure that your coupling is adequately rated for the speed and torque that you intend to run.
- Make sure all rotating elements are covered.
- Always wear safety glasses when working around dynamometer test equipment.
- Do not wear loose clothing or ties when working around dynamometer test equipment.
- Never allow anyone to stand close to the side of, or lean over, a rotating shaft coupling.
- Insulate electrical (internal and external) motor connections.



CAUTION: A POWER-LINE FAULT INTO THE DYNAMOMETER FRAME COULD PASS A TRANSIENT SURGE THROUGH ALL INTERCONNECTED INSTRUMENTS, ANY COMPUTER IN USE OR OPERATING PERSONNEL WITH DANGEROUS AND COSTLY CONSEQUENCES!

- Always connect the motor frame to a high current capacity (water pipe) earth ground.
- Be sure the motor control circuit breakers cannot be bypassed by accident. Variable auto-transformers are especially hazardous!
- When operating dynamometers with blowers, hearing protection must be worn.

4.1.2 ACCURACY

Following, is a list of several factors that affect the apparent accuracy of the torque readout.

- **Full Scale Torque Calibration:** This setting will be affected by an internal temperature rise of up to $\pm 0.0015\%$ FS/ $^{\circ}$ C. For more information on full-scale torque setup and troubleshooting, refer to Section 6.4 – Calibration Procedure and Section 8.1.3 – Full Scale Torque.
- **Zero Offset:** This setting is affected by an internal temperature rise of up to $\pm 0.002\%$ Reading/ $^{\circ}$ C. For more information on zero offset setup and troubleshooting, refer to Section 6.4 – Calibration Procedure and Section 8.1.2 – Zero Balance.
- **Coupling Losses:** If the coupling becomes hot to the touch, or if the dynamometer or motor vibrate after a period of running, coupling loss error could occur up to several percent depending on the size of the motor and dynamometer. For more detail, refer to Section 4.1.4 – Fixtures and Couplings.
- **Windage:** Negligible at speeds up to 6000 rpm. This effect is described more extensively in Section 4.1.5 – Windage.
- **Mechanical Friction:** Generally negligible on HD-400 dynamometers and larger. On HD-106 and HD-100 the user is cautioned to be aware of the effects that friction may cause. For more detail, refer to Section 4.1.6 – Friction.



Note: None of the above take into account the long-term drift effects on digital readout instrumentation. This is covered for each instrument by their individual specifications. Also, many of the above factors are dependent upon motor horsepower, fixturing and other circumstances beyond the control of Magtrol. If reasonable care is exercised, and calibration and maintenance are performed on a regular basis,, motor test data accuracy better than 0.25% of torque-speed value can be expected.

4.1.3 POWER DISSIPATION

All Magtrol Dynamometers are power absorption instruments. As a dynamometer loads a test motor, it absorbs horsepower from the motor into the hysteresis brake. The brake then converts this mechanical energy into heat.

There are finite limits to the amount of energy and resulting temperature rise that any absorption brake can withstand. Rapidly rising operating temperatures from excessive power input can cause severe mechanical distortion of the rotor assembly. This, in turn, may cause the rotating assembly to contact the stationary members that surround it. Once this happens, metal transfer and ultimately seizing of the brake assembly may occur.

Excessive power over extended periods of time may result in more obscure damage including breakdown of bearing lubricants and degradation of magnetic coil insulation. Also, exposure to temperatures over 690 °C (1275 °F) will alter the rotor's magnetic properties.



Note: Do not instantaneously apply maximum power (torque-speed) to a cold dynamometer. High temperature gradients cause differential expansions resulting in misalignment of the running air gaps between the rotor and stator assembly on the load brake. Allow all dynamometers to warm up before heavy loading. This is accomplished by gradually increasing the load to the motor. If a motor must be tested cold, warm up the dynamometer with a different motor first.



Note: Operating at the continuous power rating for periods of up to 4 hours is acceptable. However, operating for extended periods at high temperatures will result in premature component and bearing failure. Limiting the length of the cycle and the component temperatures will guard against premature failure. Where continuous duty is desired for longer time intervals, component temperatures should be maintained less than 100°C; monitoring the outside brake surface temperature is a sufficient reference.

4.1.3.1 Cooling Methods



Note: For additional details on compressed air and blower setup along with extensive information on the Air Flow Sensor feature, refer to Section 3.3.2 – Air Cooling.

4.1.3.1.1 Compressed Air

Magtrol’s HD-510, 515, 800 and 805 dynamometers are internally ported for compressed air cooling. Always use the filter and line regulator supplied with the unit. These elements should be installed as shown in the following diagram.

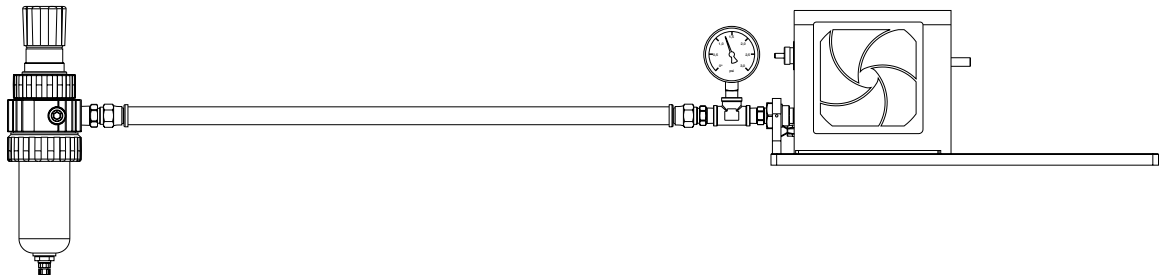

Figure 4-1 Dynamometer with Compressed Air Connection

For maximum air flow and cooling, set the regulator to the following:

HD Model	CFM (Cubic Feet per Minute)	PSI (Pounds per Square Inch)
HD-510	7	1.75
HD-515	10	4
HD-800	13	10
HD-805	15	14



WARNING! DO NOT EXCEED THE PRESSURES GIVEN.

The air supply should be enabled whenever the unit is in operation.

OPERATION

4.1.3.1.2 Blower

Magtrol’s HD-710/715/810/815/825 and ED-715/815 dynamometers are internally ported for blower cooling. The following diagram illustrates the connection.

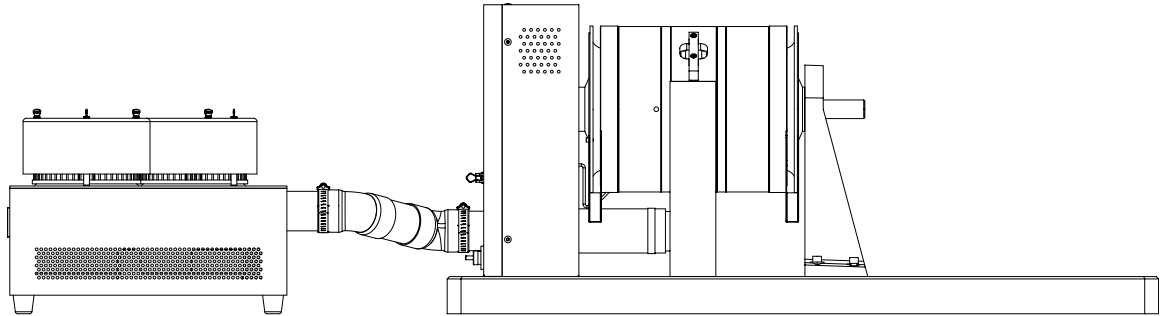

Figure 4–2 Dynamometer with Blower Connection



WARNING! DUE TO THE NOISE LEVELS OF THE BLOWERS, HEARING PROTECTION MUST BE WORN DURING OPERATION.

OPERATION

4.1.4 FIXTURES AND COUPLINGS

When mounting the test motor, please consider the following:

- Construct precise fixtures that provide proper shaft alignment.
- Secure the test motor in the fixture to prevent torsional movement and bolt the fixture to the dynamometer base plate.
- Give consideration to the interaction of materials between the motor and test fixture. For example, a (magnetic) steel plate placed against the exposed lamination of an open frame motor can significantly influence performance. Some thin shell PM (permanent magnet) motors may be similarly affected.
- The dynamometer base plate material is an aluminum tool plate that is easily drilled and tapped. The use of helix thread inserts is a good idea if you are going to interchange fixtures often.



Note: For an additional charge, Magtrol can perform base plate modifications.

The following diagram illustrates examples of possible shaft misalignment.

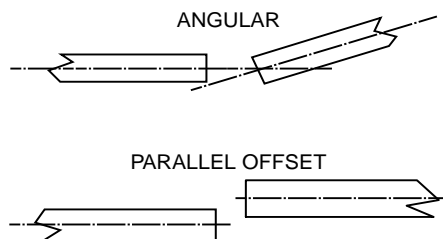

Figure 4–3 Examples of Possible Shaft Misalignment

The use of high quality double flexure couplings is recommended to help correct any misalignment problems. This type of coupling—two flexing elements separated by a solid link—inherently tolerates greater parallel offset. If you would like more specific coupling recommendations, contact Magtrol Technical Assistance. For precise misalignment tolerances, consult your coupling manufacturer.

4.1.5 WINDAGE

Windage is proportional to the square of speed and magnifies rapidly above rated speed. The air friction is tangential to the surface and impinges upon the stationary field assembly. This acts as viscous drag and becomes part of the motor load and torque reading. However, there is a small amount of air dissipated as pumping loss. Since this appears as a load on the motor, not measured by the dynamometer, it becomes a source of error.

Windage effects on accuracy tests have been conducted on all Magtrol dynamometers. The percentage of torque loss due to windage ranges between 0.025% and 0.20% of full scale at maximum rated rpm.

Windage is proportional to the square of speed and magnifies rapidly above rated speed. Conversely, at one half of the rated speed, the effect becomes immeasurably small.

4.1.6 FRICTION

Friction of the shaft bearings is a measurable load, but some friction can exist in the carrier bearing. When correctly loaded and lubricated, the friction is insignificant. The value may be quantitatively established by the following procedure.

1. Remove all attachments to the dynamometer shaft.
2. Advance the torque control slightly, to obtain a small torque load.
3. Apply a small amount of torque (by hand) in one direction of rotation.
4. Carefully release the shaft, allow several seconds, and record the torque reading, if any.
5. Then, carefully re-apply torque in the opposite direction.
6. Slowly release the shaft as above, and compare the two readings.

The difference should be less than 1% of full scale. During actual motor testing there is usually enough system vibration to “settle” negating frictional effects. If excessive drag is present, mechanical realignment may be required, dependent upon dynamometer size. Certain mechanical factors need to be determined before corrective action proceeds. Please contact Magtrol Technical Assistance.

4.1.7 VIBRATION

All rotating dynamometer assemblies are precision balanced, however, the dynamometer shaft is cantilevered. This may cause vulnerability to radial forces.

At high speeds, some vibration and noise are inevitable but not necessarily harmful. However, excessive resonant vibrations, caused by bent shafts, poor alignment and out of balance couplings will produce excessive data errors and are a safety hazard.



WARNING! SHAFT COUPLINGS OPERATING AT SPEEDS ABOVE THEIR DESIGN LIMITS ARE EXTREMELY HAZARDOUS. MANY COUPLINGS CONTAIN SOMEWHAT LOOSELY SUPPORTED FLEXURE ELEMENTS. WHEN OVERDRIVEN, EXCESSIVE CENTRIFUGAL FORCE MAY DISPLACE THEM OUT OF AXIAL ALIGNMENT. AS THIS HAPPENS, THEY IMMEDIATELY BEGIN TO ABSORB ENERGY RESULTING IN SEVERE VIBRATION AND DESTRUCTION OF THE COUPLING.

4.1.8 COGGING

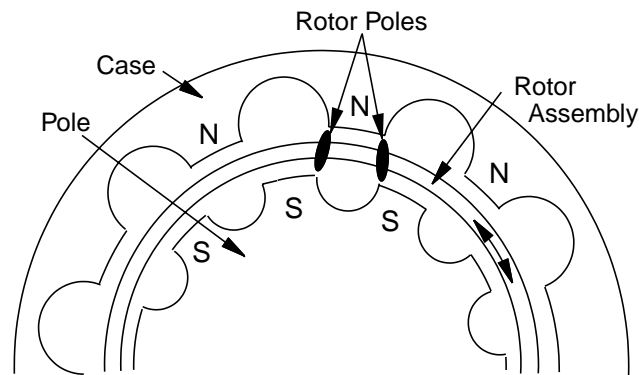

Figure 4-4 Hysteresis Brake Cross-Section

This cross-section shows (by one tooth) the magnetic relationship of the hysteresis brake elements. If the dynamometer shaft is at rest with torque applied, and if the torque control is then reduced to zero, a magnetic salient pole will be temporarily imposed on the rotor of the brake.

If the shaft is then rotated slowly, the magnetic poles on the rotor will attempt to align with the adjacent case-pole tooth form. This is often referred to as “cogging”. The action is sinusoidal—first it tries to resist rotation and then, as the rotor passes through the tooth form, it subsequently supports rotation. At a few hundred rpm, these forces integrate resulting in an effective torque of nearly zero.

To avoid magnetic cogging, before the shaft comes to rest, reduce the torque control to zero.

To remove cogging, once established, reapply current on the dynamometer. Then, decrease the current to zero while simultaneously rotating the dynamometer shaft.

4.1.9 EDDY CURRENTS

There is some Eddy current generation within the brake rotor. These magnetically induced currents cause an increase in brake torque proportional to speed.

The larger the hysteresis brake, the higher the rotor surface velocity. Additionally, as brakes become larger the rotor cross-sectional area increases. Each of these factors increase Eddy current generation. The combination results in speed-related torque increase, exhibiting a more pronounced effect on larger dynamometers.

With the HD-800 through 815 models, the Eddy-current torque component adds approximately 10%/1000 rpm to a static, fixed current, torque value. On the smaller dynamometer sizes, 2% to 4%/1000 rpm is typical.

4.1.10 TEMPERATURE RISE

Temperature rise has a more complex effect on hysteresis brake load torque and is difficult to quantify. As the temperature of the brake increases, differential expansions cause dimensional changes that tend to increase torque. Conversely, electrical resistance in the rotor increases with temperature, resulting in decreased Eddy current generation and torque, all in a variable frame.

Where current and speed remain fixed, there may be a gradual torque increase over a period of a few moments. This will generally stabilize at 0.5% (for small dynamometers, up to HD-500) to 2% of the starting torque value, per 1000 rpm of applied speed.



Note: If highly accurate long-term torque stability is required, consider the Magtrol DSP7010 Series Dynamometer Controller. This is a computer-controlled closed loop system capable of maintaining either constant torque or speed.

5. Operating Principles

5.1 SPEED

Inside the dynamometer enclosure is an optical speed transducer. A high-speed optical switch, consisting of an Infrared (IR) LED and IR receiver, senses the passage of light through a segmented disk that is attached to the end of the dynamometer shaft. Light passing through a clear segment in the disk causes the speed output signal to go to a logic low (near 0 VDC). As an opaque segment passes in front of the IR receiver, the output signal switches to a logic high (near 5 VDC). Rotation of the disk results in the optical switch generating a pulse frequency of 60 PPR (pulses per revolution). For schematic, see Section B.2 – Speed Sensor Board in Appendix B.

5.2 TORQUE

Torsional force from the hysteresis brake assembly is measured by a load cell. The load cell consists of a flexing beam with four strain gauges. The strain gauges are in a bridge configuration, producing an analog signal proportional to torque.

The load cell schematic in Appendix B shows voltage levels and connection identifications. The mechanical diagram below illustrates how the assembly clamps onto the rear support member of the brake.

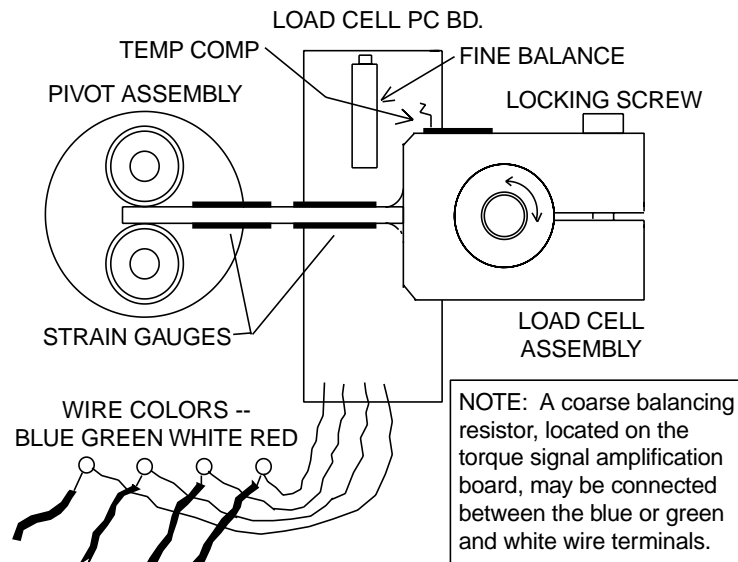

Figure 5-1 Mechanical Layout of a Load Cell

5.3 TORQUE SIGNAL AMPLIFICATION

A printed circuit board mounted on the dynamometer rear panel, identified as part number 234-401-101-xxx, contains the torque signal amplifiers IC1, IC2 and IC3, load cell excitation supply consisting of voltage reference DZ1, amplifier IC4 and Transistors Q1-Q4.

Voltage reference DZ1 is a precision voltage source, and along with IC4 and Q1-Q4, provides +5.00 and -5.00 volts DC excitation to the load cell bridge. Transistors Q1-Q4 are NPN and PNP transistors, serving as series pass elements to boost the current output drive capability to over 30 mA. Bipolar bridge excitation is used to improve the noise immunity of the low millivolt range bridge output signal. See B.1 – Torque Amplification Signal in Appendix B.

Amplifier IC1 is a precision, differential input instrumentation amplifier providing amplification necessary to calibrate the torque signal. IC2 and IC3 provide additional amplification and scaling, along with the counterclockwise calibration (CCW CAL) control.

The torque signal is calibrated by adjusting the rear panel trim potentiometers P1 and P2, labeled “CW CAL” and “CCW CAL”. Torque signal zero is adjusted by using the rear panel trim potentiometer P3, labeled “ZERO”, when no torque is applied.

The load cell on all dynamometers except the HD-106, produce an output signal of 15 mV at full torque. The HD-106 output is 7.5 mV full scale. Amplifiers IC1-IC3 calibrate this so the output in millivolts equals the dynamometer full scale torque.

The torque signal zero may be affected thermally and may need periodic readjustment. Therefore, the “ZERO” adjustment can be readjusted as needed.

The clockwise calibration (CW CAL) adjustments should not typically need readjustment. In the event that a “CW CAL” adjustment is needed, a precision calibration beam and weight must be used. The calibration beam may be purchased from Magtrol.



Use only an insulated screwdriver or a plastic trim pot adjustment tool when adjusting the “CW CAL,” “CCW CAL” or “ZERO” trim potentiometers.

For example, the HD-400-5 Dynamometer lists the full scale torque at 0.280 N·m. Therefore, the amplifier gain will be set to produce ± 5.000 VDC output, when the load cell input is ± 0.015 VDC.

5.4 DECIMAL POINT CONTROL

Two solder links on the circuit board indicate to the digital readout instrument where the decimal point belongs. The chart below shows how this is accomplished by jumping the appropriate link on the board. Digital output “XXX” represents the result of the analog output (in millivolts) with the decimal point properly located.

Digital Output	SL13	SL12
X.XX	Closed	Open
XX.X	Open	Closed
XXX.	Closed	Closed

5.5 DAMPER CYLINDER

Hysteresis brakes, machined from (solid bar) magnetic material, represent a heavy mass. The load cell behaves somewhat like a spring. A mass, supported by a spring, will resonate at the system's natural frequency. For this reason, the dynamometer brake assembly must be dampened to filter out torque data and to avoid stress and fatigue. The damper cylinder arm, attached to the brake, connects to a piston within the hydraulic cylinder. When the load cell shipping/restraining bolt was removed (see Section 3.1 – Removal of the Load Cell Shipping/Restraining Bolt), the brake/load cell assembly was centered and the damper became functional.

5.6 BRAKE CONTROL POWER

Any Magtrol Dynamometer Controller is universal in that it must operate all dynamometers. Due to the higher level of current required by Magtrol's larger dynamometers, a booster power amplifier is used to increase the control current. These supplies, contained within the dynamometer enclosures, are in operation when the cooling fans are on.

5.6.1 HD-800/815 AND ED-815

A booster power amplifier is used to increase control current by a factor of 2 with the HD-800 and 810 and a factor of 4 with the HD-805, 815 and ED-815 dynamometers. The schematic in Section B.4 – HD-800-815 Brake Control Supply details the HD-800, 805, 810 and 815 brake power amplifier.

5.6.2 HD-825

An HD-825 uses a 5241 power amplifier to increase the control current. For the schematic, see Section B.5 – HD-825 Brake Control Supply.

6. Calibration

6.1 INITIAL CALIBRATION

All Magtrol instruments are calibrated prior to shipment. There is a calibration label on each unit as shown in the following figure.



Figure 6–1 Calibration Label

This label tells the user when the next calibration is required, although Magtrol does recommend that calibration be completed after the dynamometer, readout instrumentation and power supply are set up for the first time.

6.2 CALIBRATION BEAMS AND WEIGHTS

To perform a successful dynamometer calibration, a precision weight heavy enough to apply a torque at or close to the full scale rating is required. Magtrol offers precision weights (WT Series) and calibration beams (CB Series) rated specifically for each Hysteresis Dynamometer.



Note: The Pin Location represents the distance between the pin and the center of the calibration beam. See Figure 6–4 Calibration Calculation.

Calibration Beam Assembly	For Hysteresis Dynamometer	Full Scale Torque	Pin Location	Weights	
			cm	Size	Model
CB-106	HD-106	0.018 N·m	9.18	20 g	WT-106M
CB-100	HD-100	0.08 N·m	8.16	100 g	WT-100M
CB-400	HD-400	0.28 N·m	14.28	200 g	WT-400M
CB-500	HD-500	0.85 N·m	17.34	500 g	WT-500M
	HD-510				
	HD-505	1.70 N·m	17.34	1.0 kg	WT-505M
HD-515					
CB-700	HD-700	3.10 N·m	31.61	1.0 kg	WT-700M
	HD-710				
	HD-705	6.20 N·m	31.61	2.0 kg	WT-705M
HD-715					
CB-800	HD-800	14.0 N·m	47.59	3.0 kg	WT-800M
	HD-810				
	HD-805	28.0 N·m	47.59	6.0 kg	WT-805M
HD-815					
CB-825	HD-825	56.5 N·m	38.41	15.0 kg	WT-825M

MAINTENANCE

6.3 CALIBRATION PREPARATION

Before beginning the calibration procedure, the following items must be checked.

- Be sure all equipment is set for the correct power-line input voltage as specified on the original order.
- Ensure correct earth grounds on equipment.
- For instructions and operational details on how to set an open loop current, refer to your power supply manual.
- Turn on the controller or readout and power supply and allow 20 minutes for warm-up, longer if the equipment is below room temperature.

6.4 CALIBRATION PROCEDURE

The calibration procedure is as follows:



Note: Do not hang the weight until instructed to do so in step 4.

1. Place the calibration beam onto the dynamometer shaft, inserting the shaft through the center hole of the beam. Secure by tightening the clamping screws. See Figure 6–2.



Note: If the shaft has a flat, make sure that the flat is facing down and tighten the clamping screw(s) against the flat only.



Figure 6–2 Calibration Setup

2. Apply full current to the dynamometer brake.
3. With the beam perfectly horizontal, use a flathead screwdriver to adjust the ZERO trim pot (located on the rear panel) so that the torque reading is zero \pm 1 least significant dynamometer torque digit.

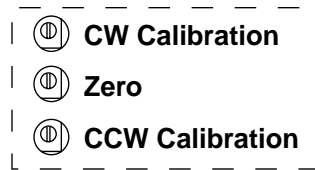
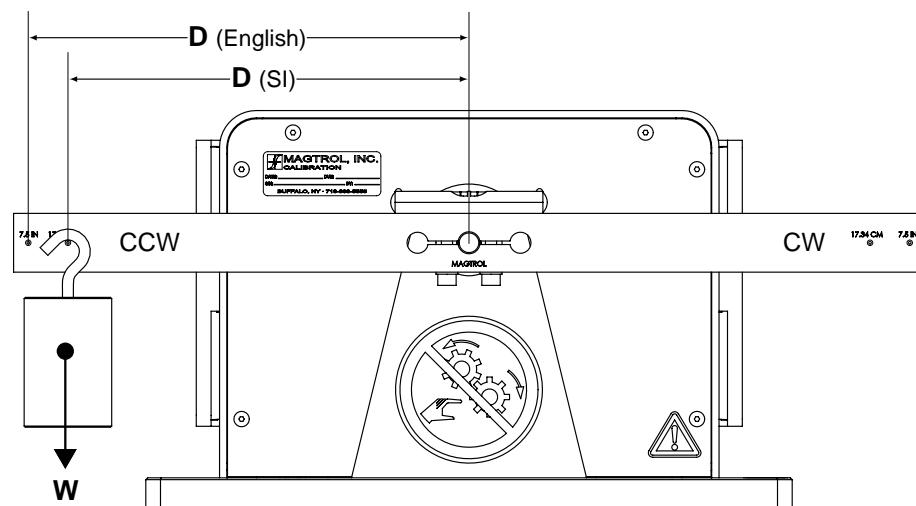

Figure 6-3 Calibration Potentiometers

4. Hang the weight from the clockwise (right) pin and level the calibration beam.



Note: To hang bottleneck weights, Magtrol recommends using only lightweight (but strong) line. Simply fashion a loop and attach it to the weight.



$$\text{Torque} = \text{Weight (W)} \times \text{Distance (D)}$$

$$\text{Weight (W)} = \text{Torque} / \text{Distance (D)}$$

Figure 6-4 Calibration Calculation

5. Adjust the CW Calibration trim pot so that the torque reading equals the weight times the distance.



Note: If using Magtrol CB Calibration Beams in conjunction with WT Calibration Weights, simply calibrate to the full scale torque listed in the table in Section 6.1 – Calibration Beams and Weights.

6. Transfer the weight to the counterclockwise (left) pin and level the dynamometer.
7. Adjust the CCW Calibration trim pot so that the torque reading equals the weight times the distance. See Note in step #5.
8. Remove the weight from the calibration beam.

MAINTENANCE

9. Reduce the current to zero while pumping the calibration beam CW/CCW (moving it up and down). This will ensure that the rotor does not remain magnetized in one specific location (becoming “cogged”), thus preventing the shaft from rotating freely. For more information, refer to Section 4.1.8 – Cogging.
10. Remove the calibration beam.

The dynamometer is calibrated and ready for motor testing.

6.5 CALIBRATION FREQUENCY

Magtrol load cells are temperature compensated and designed for stability. It is a good idea to calibrate, frequently at first, maintaining a record (see Appendix A – Calibration Record) until you have established a history. If there appears to be excessive drift, contact Magtrol Technical Assistance.

7. Optional Features

7.1 SPEED ENCODER

All Magtrol dynamometers come standard with a 60-PPR speed encoder, best suited for high-speed systems. For low speed motors, with maximum speeds of less than 200 rpm, Magtrol offers several additional encoder options, which include:

- 60/600-PPR dual encoder
- 60/6000-PPR dual encoder

With the dual encoder option, the dynamometer comes equipped with a standard 60-PPR encoder and an additional 600 or 6000-PPR encoder. The user can select which encoder to use via a back panel switch. (See Figure 2-1 Rear Panel). Four of the wires route to a four pole double throw switch. The switch selects which encoder will be powered up and routes the appropriate Tach_A, Tach_B, and Index signals to the 15-pin connector. See section 2.2.

The 60 PPR encoder may be used for high speed systems and the 600/6000-PPR encoder for lower speed applications. Additionally the TACH_A and TACH_B signals can be quadrature decoded to give even higher resolutions and direction of rotation.

8. Troubleshooting

8.1 TORQUE READOUT PROBLEMS

8.1.1 NEW DYNAMOMETER

If the dynamometer is new (never operated before) and the torque reading is near full scale and constant, the probable cause is failure to remove the shipping restraining bolt. This applies to all dynamometers with model numbers 106, 400, 5XX, and 7XX. For further instruction refer to Section 3.1 – Removal of the Load Cell/Shipping Restraining Bolt.

8.1.2 ZERO BALANCE

Zero balance is usually attained by the ZERO control potentiometer on the rear panel of the dynamometer. Refer to Section 6.2 – Calibration Procedure. If you cannot obtain a zero torque reading with zero applied torque, you will need to first make sure that your load cell is functional. To verify that the strain gauge is stable under stress, complete the following steps.

1. Install the calibration beam.
2. Set the power supply for full current.
3. Install a weight on the beam (either side) sufficient to apply close to 100% of full-scale rated torque. If the reading is stable, switch the weight to the other side of the beam.
4. Steady the weight and the beam to be sure they are motionless.



Note: The torque reading may show activity, but hold steady within three or four dynamometer torque digits.

8.1.2.1 Steady Torque Reading

If the torque reading is active and steady, you will need to reestablish the zero load cell balance.

1. Adjust the zero control on the rear panel for an approximate mechanical center. This is a 20 turn control, so rotate it clockwise more than 20 turns and then counterclockwise for 10 turns.
2. Disconnect the dynamometer line cord from the line power source.
3. Turn off the digital readout device or dynamometer controller.
4. Lower the rear panel.



Note: It is a good idea to clamp the rear panel to the dynamometer base plate. This will decrease the possibility of pulling on the fragile interconnection lead wires.

5. Remove resistor R20 from the torque amplification circuit board.
6. Turn on the digital readout instrument.
7. While observing (or recording) the torque reading, start with a 100 K to 200 K resistor and temporarily connect it in the R20 position on the circuit board.
8. Temporarily jumper solder link SL14. If the reading becomes larger, remove the jumper and bridge solder link SL 17. If the reading becomes smaller, remove the jumper and bridge solder link SL 14.
9. Select resistors until two adjacent resistance values, within 1% or 2% of each other, cause

the reading to swing through zero. Do not use any resistance below 10K.

10. Once the correct resistance value has been established, a high quality 50 ppm/°C, 1% or better, precision resistor (RN60C or RN65C) must be obtained. Permanently solder it onto the board in the R20 position.
11. The ZERO control potentiometer, which was previously set to a mechanical center, should now trim out any remaining imbalance.



Note: If something has caused the original balance to shift to such an extent that the rear panel ZERO balancing control is out of range, it is probable that more difficulties lie ahead. Whereas a new load cell might offer the best solution, these instructions may get the dynamometer operational.

8.1.2.2 Erratic Torque Reading

If the torque reading is erratic, then the problem could be a defective load cell or electronic component in the dynamometer or readout device. It will be necessary to establish specifically what is defective. At this time contact Magtrol Technical Assistance.

8.1.3 FULL SCALE TORQUE

If the dynamometer cannot obtain full torque and will not support the beam and weight at full scale, a resistance or current check may be used to help locate the problem.

8.1.3.1 Resistance Check

1. Disconnect the 2-pin or 4-pin connector and the dynamometer line cord.
2. Measure the resistance across the 2-pin male plug or across pins 3 and 4 on the 4-pin male plug at the dynamometer.
3. Check the reading to the table below.

Dynamometer Model	Resistance @ 20 °C Ω
HD-106	171
HD-100	180
HD-400	80
HD-500	75
HD-510	75
HD-505	37.5
HD-515	37.5
HD-700	80
HD-710	80
HD-705	40
HD-715	40
HD-800	20
HD-810	20
HD-805	10
HD-815	10
HD-825	5
ED-715	40
ED-815	13

If the reading is within $\pm 10\%$ of the value specified in the table, proceed to Section 8.1.3.2 – Current Check . If the reading is not within the values specified, contact Magtrol Technical Assistance.



Note: The resistance check in the table is accurate for Magtrol HD-106, -100, -400, -5XX Series and -7XX Series, ED-715 and HD-825 Dynamometers. The HD-800, 805, 810 and 815 Dynamometers have circuitry between the connector and the brake coil. The brake coil must be isolated from this circuitry for the resistance in the table to be accurate.

8.1.3.2 Current Check

1. Insert an ammeter between the power supply and dynamometer brake.
2. Adjust the power supply voltage until the ammeter reading is equal to the value in the following table.

Dynamometer Model	F.S. Current A
HD-106	0.145
HD-100	0.135
HD-400	0.300
HD-500	0.298
HD-510	0.298
HD-505	0.596
HD-515	0.596
HD-700	0.339
HD-710	0.339
HD-705	0.678
HD-715	0.678
HD-800	1.200
HD-810	1.200
HD-805	2.400
HD-815	2.400
HD-825	4.800
ED-715	0.678
ED-815	2.400

3. Attach the appropriate weight for full-scale torque and verify whether the brake holds the load. If it does not hold the load with proper current flowing in the brake, the power supply is not the problem. The dynamometer is probably at fault and you will need to contact Magtrol Technical Assistance for further help.



Note: The current check is accurate for all Magtrol Dynamometers.

MAINTENANCE

8.1.4 MECHANICAL (ROTATIONAL) ALIGNMENT

Refer to the drawing and the instructions below if the dynamometer will apply torque but the torque reading will not calibrate full scale, even though the zero balance is within tolerance. See Figure 5–1 Mechanical Layout of a Load Cell.

1. Disconnect all inputs and outputs on the dynamometer rear panel.
2. Disconnect the dynamometer line cord from the line power source if applicable.
3. Carefully remove the rear panel.



CAUTION: IT IS A GOOD IDEA TO CLAMP THE REAR PANEL TO THE DYNAMOMETER BASE PLATE.

4. On some older models with large metal pulse disks, the pulse disk may be vulnerable to damage, and should be removed temporarily. Loosen the socket-head cap screw retaining the pulse disk to the shaft, and remove the pulse disk.
5. Loosen, but do not remove, the load cell clamping screw.
6. Carefully grasp the brake assembly and slowly rotate the assembly in both directions. Please note several degrees of free-swing. The objective is to reposition the load cell in such a manner to re-establish the center of allowable rotation, restricted by the damper assembly.



CAUTION: Do not force this assembly!

- 7a. For HD-7XX and HD-8XX dynamometers, the damper cylinder will provide some restraint on the limits of rotation, but should not be forced.

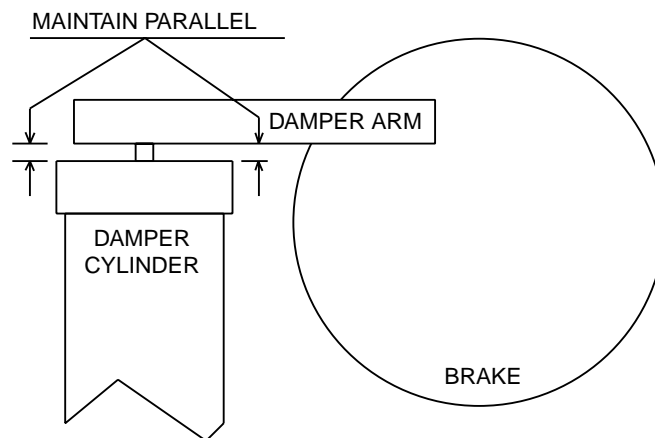

Figure 8–1 Damper Connection (HD-8XX Series)

- 7b. For smaller dynamometers, (HD-5XX and smaller) the damper cylinder uses a rubber diaphragm seal, and care must be taken to avoid over stressing the diaphragm!
- 8a. For HD-8XX dynamometers: Devise a shim of sufficient thickness, that when inserted between the top of the damper cylinder and the damper arm, the arm will be parallel to the top of the cylinder. Press down on the damper arm to hold brake in this centered position for step 9.
- 8b. For HD-7XX, 5XX, 400 dynamometers: Install the shipping screw. This will center the brake in its rotation.

- 8c. For HD-100, 106, contact Magtrol service department (service@magtrol.com) for instructions.
9. Tighten the load cell clamping screw. Be sure the load cell assembly has not moved axially and is seated against the sleeve resting up against the inner race of the carrier bearing.
10. For HD-8XX: Remove the shim.
11. Reinstall the pulse disk if it was previously removed, reassemble the enclosure and then recalibrate.

8.2 SPEED READOUT PROBLEMS

If there is an erratic speed reading, or no speed reading at all, remove the rear panel of the dynamometer and inspect the pulse disk. It must be tight on the rotor shaft and the shaft must rotate freely. Also, make sure that the disk is not bent or distorted. If the disk is damaged, contact Magtrol Technical Assistance (service@magtrol.com) for a replacement disk.

If the pulse disk appears normal, then connect an oscilloscope with the probes across pins 9 and 11 of the dynamometer 15-pin “D” connector (on older models: pins 8 and 10 of the dynamometer 14-pin connector). See Section 2.2 for connector diagram. As the disk rotates, the pulse voltage should switch between a low of about 0.4 VDC (or less) and a high of about 5 VDC. If this signal is incorrect, the problem is on the encoder optical pickup board. The encoder optical pickup is replaceable as an assembly from the Magtrol Technical Assistance Department. If this signal is correct, examine your digital readout instrument for the problem.

Appendix B: Schematics

B.1 234-401-031 BOARD

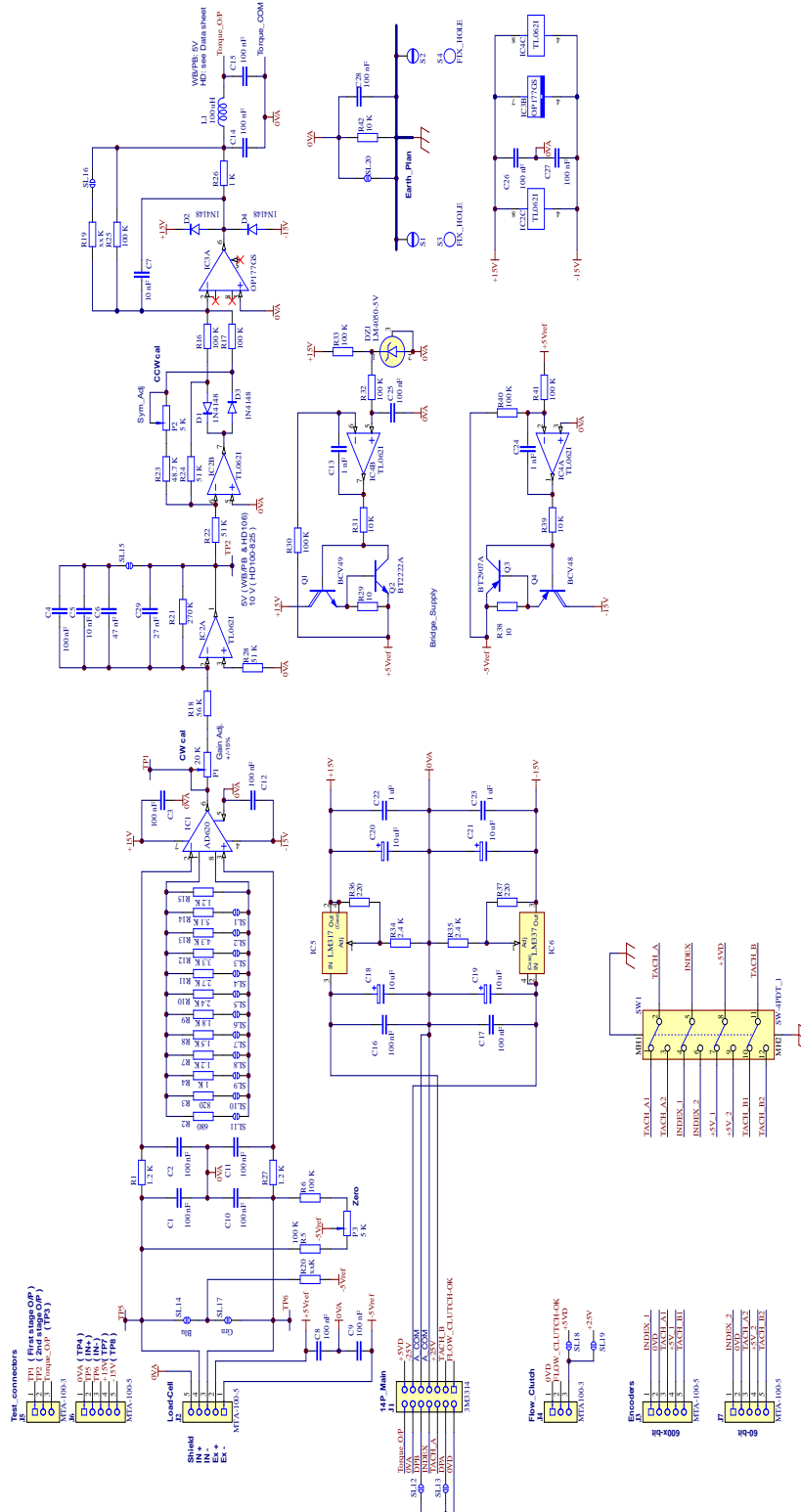

B.2 SPEED SENSOR BOARD

Prior to 2015 dynamometers:

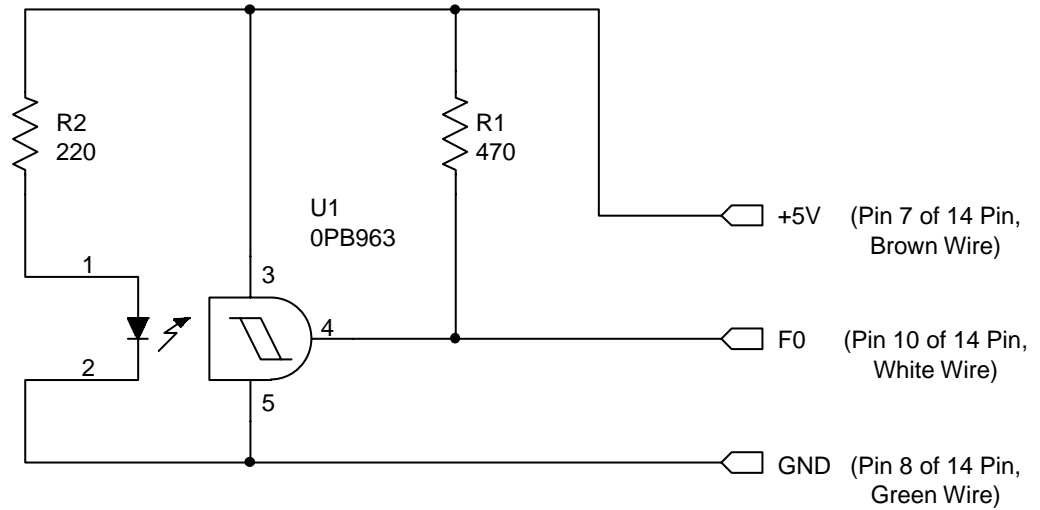

2015 - 2022 dynamometers:

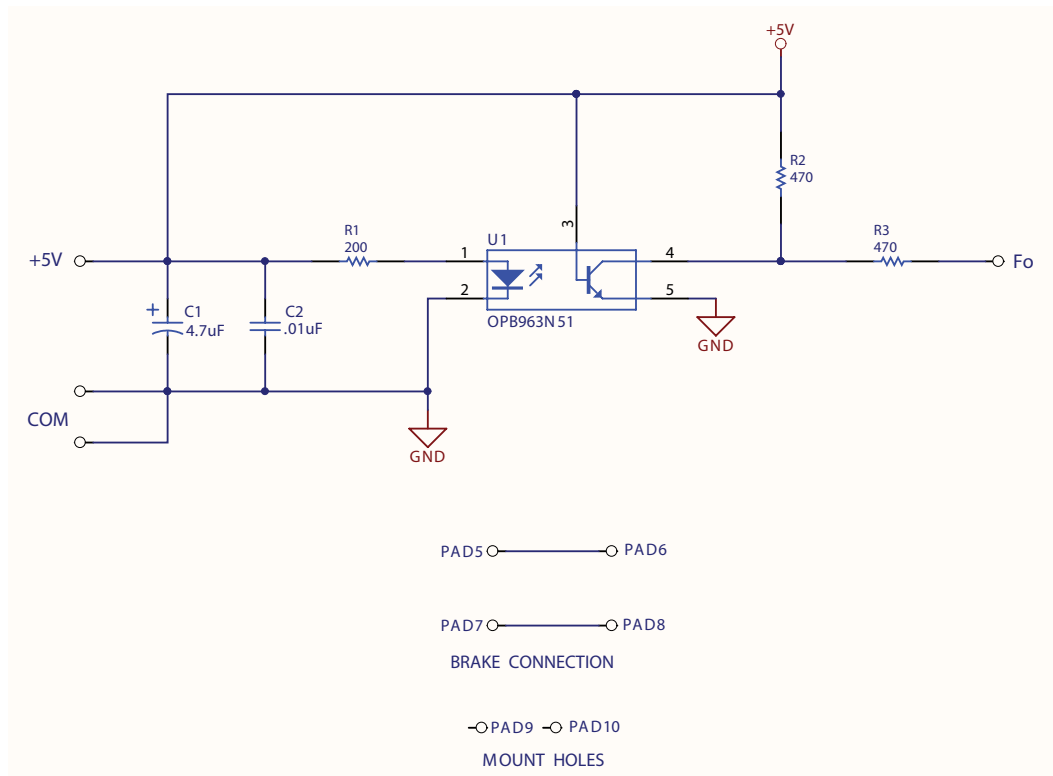

B.3 LOAD CELL SCHEMATIC

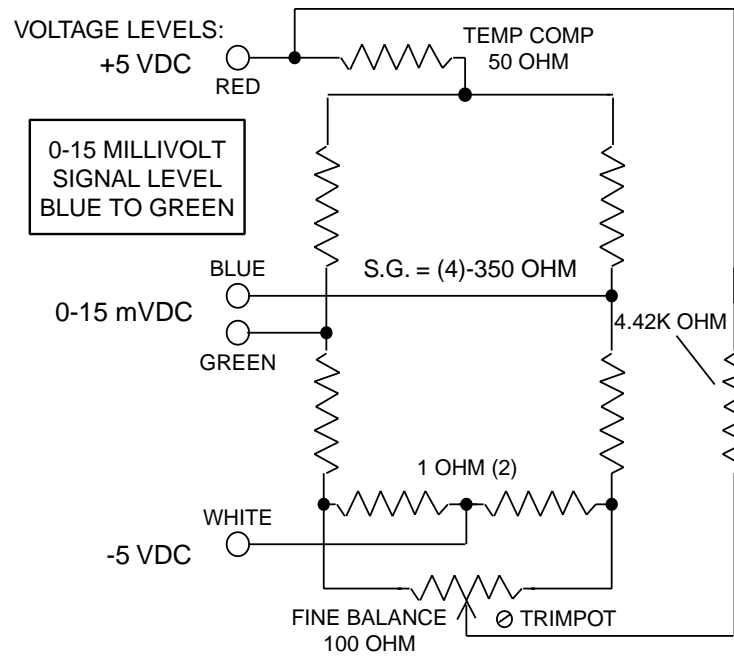

B.4 HD-800-815 BRAKE CONTROL SUPPLY

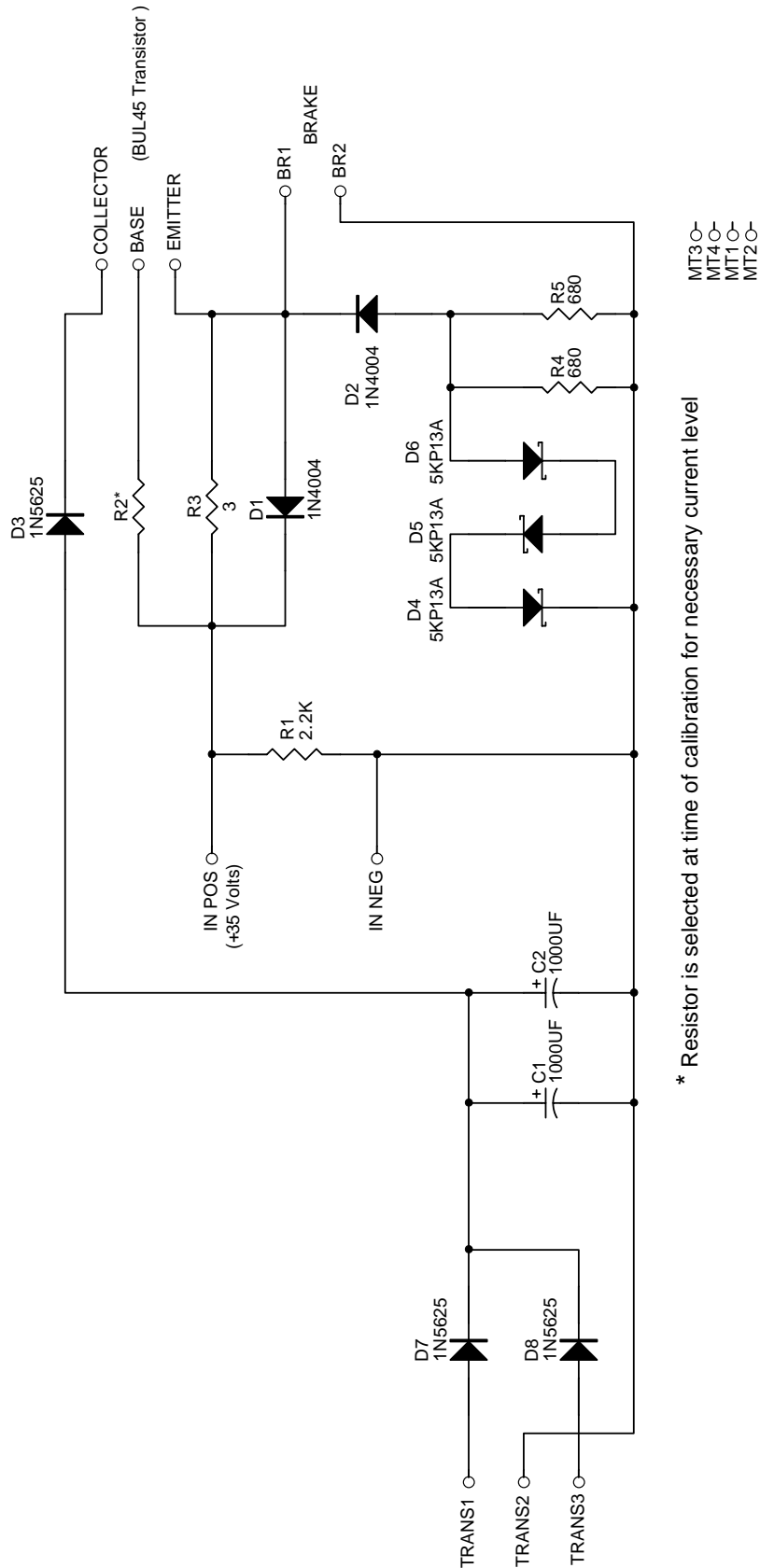

B.5 HD-825 BRAKE CONTROL SUPPLY

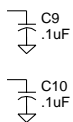
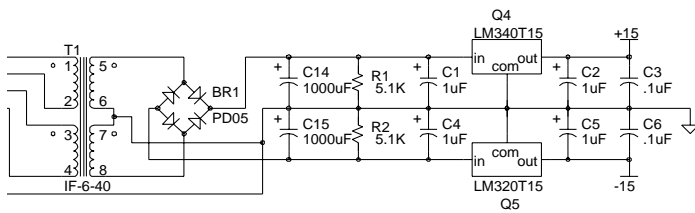
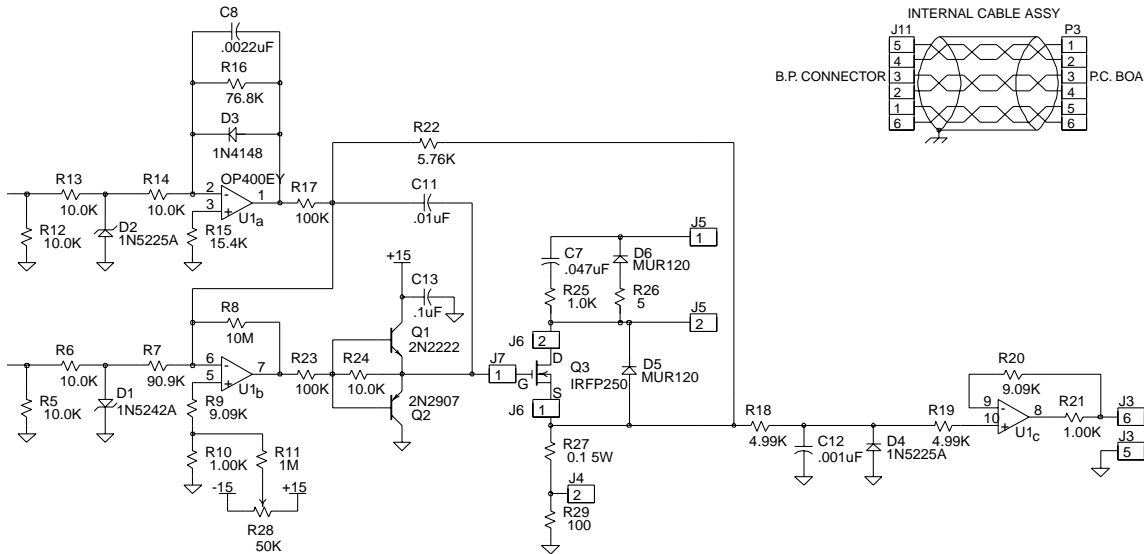
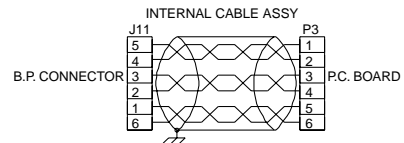
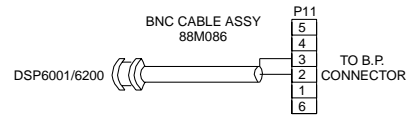
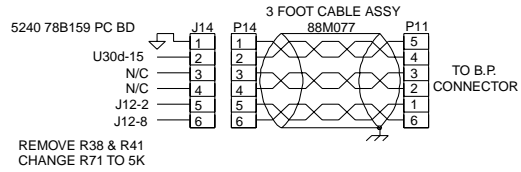
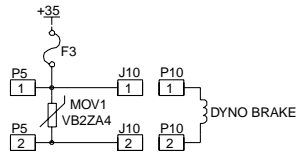
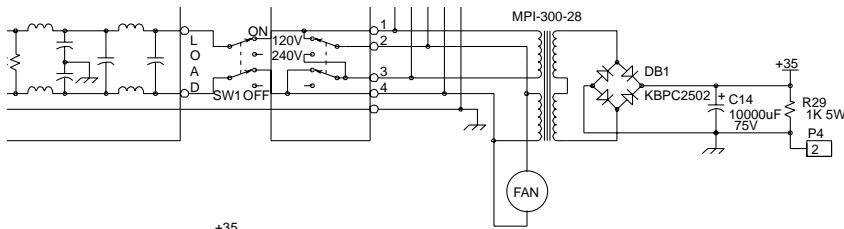

Index

A

Accuracy 24
Air Cooling 22

B

Blower
 Connection 36
 Input 16
 Setup 23
Brake Control Power 43
Brake Control Power Supply
 HD-800 to HD-815 57
 HD-825 58

C

Calibration 44
Calibration Beams 44
Calibration Potentiometer 16
Calibration Record 54
Calibration Weights 44
Cogging 39
Compressed Air
 Connection 35
 Input 16
 Setup 23
Cooling Methods 35
Coupling Losses 24
Couplings 37
Current Check 51

D

Damper Cylinder 43
Data Sheet 3
Decimal Point Control 42
Dynamometer Brake Input 15
Dynamometer Connector 15

E

Earth Ground 19
Eddy Currents 39
Encoder Switch 16
Erratic Torque Reading 50

F

Features 2
Fixtures 37
Friction 38
Full Scale Torque 50
Full Scale Torque Calibration 24

I

Inputs 15
 Blower 16
 Compressed Air 16
 Dynamometer Brake 15

L

Load Cell 41
Load Cell Schematic 56

M

Manual Test Systems 20
Mechanical Alignment 52

O

Outputs 15

P

PC-Based Test Systems 21
Power Absorption Curves 25
Power Dissipation 25

R

Rear Panel 15
Resistance Check 50
Rotational Alignment 52

S

Safety 24
Shaft Misalignment 37
Shipping Bolt 1,17
Speed 41
Speed Encoder 48
Speed Readout Problems 53
Speed Sensor Board 56
System Configurations 20
 Manual 20
 PC-Based 21

T

Temperature Rise 40
Torque 41
Torque Amplification Board 55
Torque Readout Problems 49
Torque Signal Amplification 42
Troubleshooting 48,49

U

Unpacking 1

V

Vibration 38

W

Windage 24,37

Z

Zero Balance 49

Zero Offset 24

Service Information

RETURNING MAGTROL EQUIPMENT FOR REPAIR AND/OR CALIBRATION

Before returning equipment to Magtrol for repair and/or calibration, please visit Magtrol's Web site at <http://www.magtrol.com/support/rma.htm> to begin the Return Material Authorization (RMA) process. Depending on where the equipment is located and which unit(s) will be returned, you will be directed to either ship your equipment back to Magtrol, Inc. in the United States or Magtrol SA in Switzerland.

Returning Equipment to Magtrol, Inc. (United States)

When returning equipment to Magtrol, Inc.'s factory in the United States for repair and/or calibration, a completed Return Material Authorization (RMA) form is required.

1. Visit Magtrol's Web site at <http://www.magtrol.com/support/rma.htm> to begin the RMA process.
2. Complete the RMA form online and submit.
3. An RMA number will be issued to you via e-mail. Include this number on all return documentation.
4. Ship your equipment to:
MAGTROL, INC.
70 Gardenville Parkway
Buffalo, NY 14224
Attn: Repair Department
5. After Magtrol's Repair Department receives and analyzes your equipment, a quotation listing all the necessary parts and labor costs, if any, will be faxed or e-mailed to you.
6. After receiving your repair estimate, provide Magtrol with a P.O. number as soon as possible. A purchase order confirming the cost quoted is required before your equipment can be returned.

Returning Equipment to Magtrol SA (Switzerland)

If you are directed to ship your equipment to Switzerland, no RMA form/number is required. Just send your equipment directly to Magtrol SA in Switzerland and follow these shipment instructions:

1. Ship your equipment to:
MAGTROL SA
After Sales Service
Route de Montena 77
1728 Rossens / Fribourg
Switzerland
VAT No: 485 572
2. Please use our forwarder : TNT • 1-800-558-5555 • Account No 154033
Only ship ECONOMIC way (3 days max. within Europe)
3. Include the following documents with your equipment:
 - Delivery note with Magtrol SA's address (as listed above)
 - Three pro forma invoices with:
 - Your VAT number
 - Description of returned goods
 - Noticed failures
 - Value - for customs purposes only
 - Origin of the goods (in general, Switzerland)
4. A cost estimate for repair will be sent to you as soon as the goods have been analyzed. If the repair charges do not exceed 25% the price of a new unit, the repair or calibration will be completed without requiring prior customer authorization.



Testing, Measurement and Control of Torque-Speed-Power • Load-Force-Weight • Tension • Displacement

