

TF 300 SERIES

TORQUE FLANGE SENSORS

FEATURES

- Complete torque measuring system including: measuring flange with signal amplifier, HF transmitter, conditioner and 4 m coaxial cable
- Contactless signal transmission: via telemetry
- Torque Range: 20 N·m ... 150 kN·m (higher torque on request)
- High Accuracy: 0.1 ... 0.2 % (0.05 % on request)
- Overload Capacity: up to 200 % (limit of adhesion)
- Measuring Range: 200 %
- Breaking Limit: >400%
- Compact, easy-to-mount design
- High torsional stiffness
- Bearingless: maintenance and wear-free
- Excellent noise immunity and shock resistance
- Protection class: IP42 (IP54 & IP65 option)
- Integrated speed sensor and conditioner for rotational speed measurement (option)
- High temperature capability: up to 125 °C (option)



Fig. 1: Torque Flange Sensors TF 313 & TF 318 with HF Transmitter and Torque Signal Conditioner

DESCRIPTION

With its compact, bearingless, maintenance-free design, the TF 300 Series Torque Flange Sensor from Magtrol brings many appealing advantages to torque measurement applications. The TF's high torsional rigidity supports direct mounting on the machine shaft or flange, avoiding the use of couplings on one side. This allows easy integration into a test system, shortens the overall length of the test bench and reduces costs.

Based on strain-gauge technology, the TF 300 Series Sensor's precise telemetry system enables highly accurate signal transmission. A signal amplifier mounted in the measuring flange amplifies the measuring signal, modulates it to high frequency and transmits it inductively (via the HF transmitter) to the conditioner. In the signal conditioner, the digitized torque signal

is transformed into an analog output signal of ± 5 VDC. Rotational speed can be measured and converted to a TTL output signal with the optional speed sensor.

The contactless design of the Torque Flange Sensor permits a gap of up to 5 mm (typically 2 or 3 mm) between the rotor antenna and HF transmitter, which makes the signal acquisition insensitive to any axial or radial misalignment. Another advantage of this torque measurement system is its insusceptibility to signal interference due to the fact that, unlike other designs, the antenna does not need to be looped around the measuring flange. Additionally, a protective cover can be mounted close to the TF Series Torque Flange Sensor with no effect on the signal.

ASSEMBLY

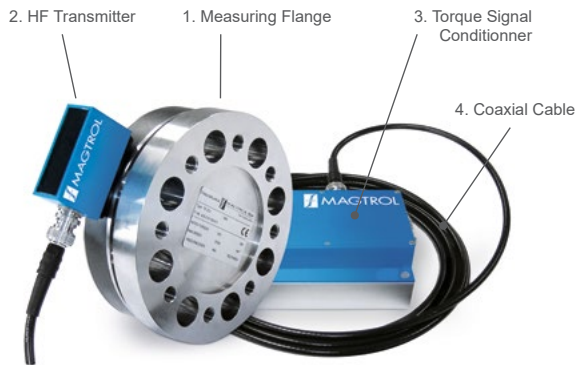

APPLICATIONS

TF 300 Series Torque Flange Sensors measure both static and dynamic torque on stationary and rotating shafts.

They are used in general combustion engine, electric motor and gearbox test benches; and can also be mounted inline for active torque monitoring of transmissions, powertrains, wind generators, gas turbines, boat engines, etc.

SYSTEM CONFIGURATION

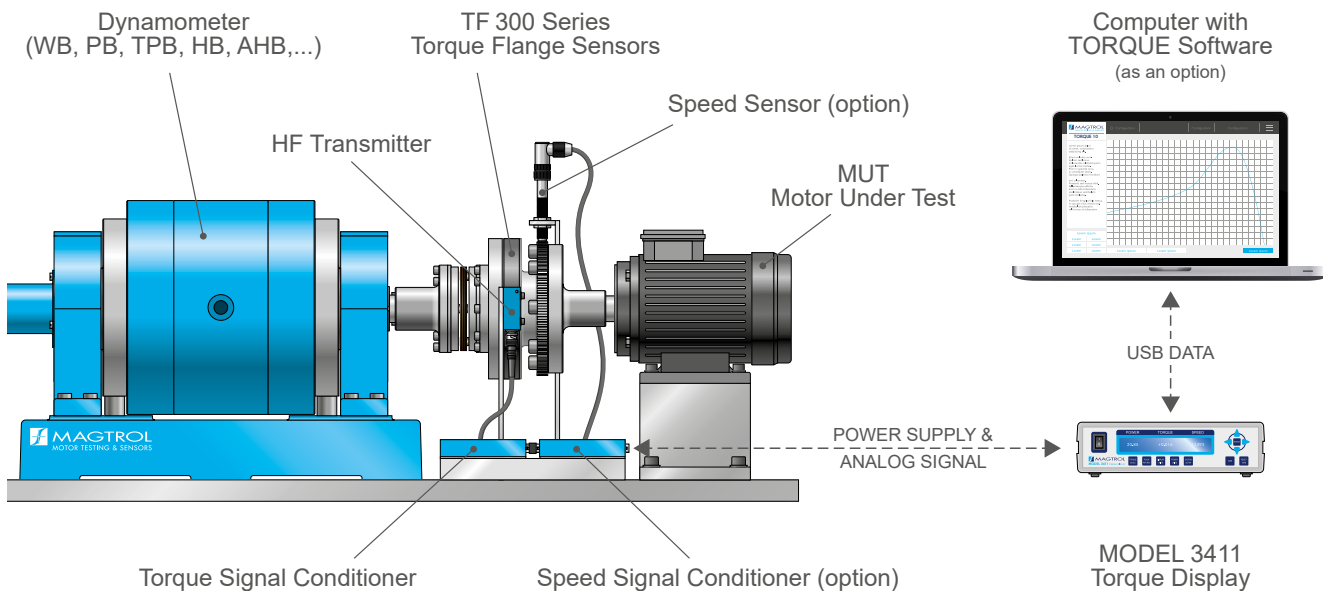

ELECTRICAL CONFIGURATION

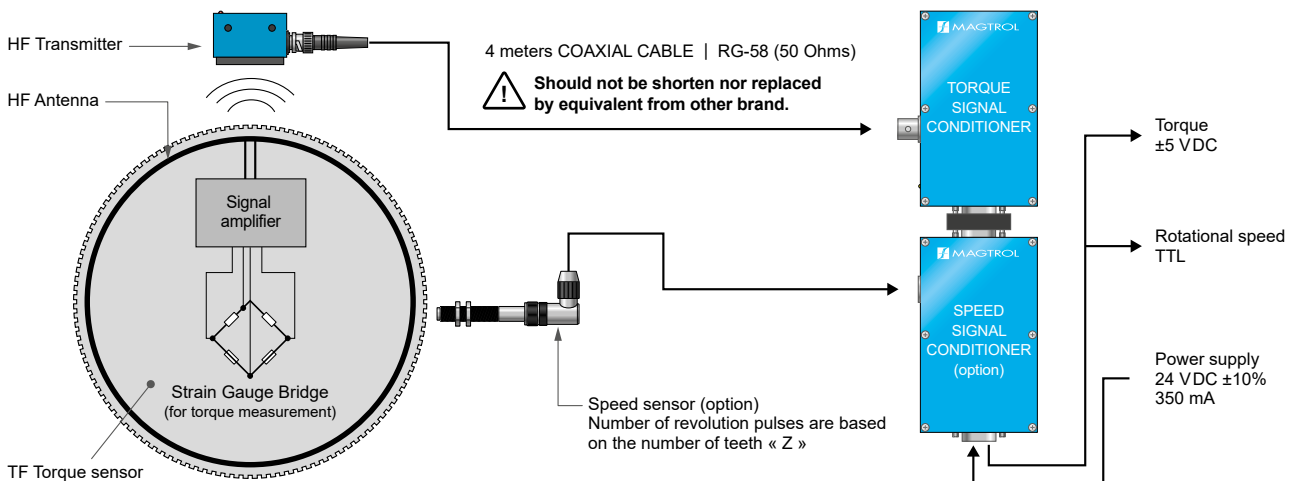

TECHNICAL DATA
MECHANICAL CHARACTERISTICS

MODEL ^{a)}	RATED TORQUE	OVERLOAD CAPACITY	ACCURACY CLASS	MAXIMUM SPEED	NUMBER OF THEETH ^{c)}	TORSIONAL STIFFNESS	DEFORMATION ANGLE	SENSORS WEIGHT ^{d)}	MOMENT OF INERTIA (X Axis) ^{f)}	
	N·m	% of RT		rpm		Z	kN·m / rad		°	kg
TF309 TFHS309	20	200%	0.1%	17 000 20 000	52	50	0.023	1.4	0.0022	0.0016
TF310 TFHS310	50	200%	0.1%	17 000 20 000	52	72	0.040	1.5	0.0022	0.0017
TF311 TFHS311	100	200%	0.1% ^{b)}	17 000 20 000	52	86	0.067	1.5	0.0022	0.0017
TF312 TFHS312	200	200%	0.1% ^{b)}	17 000 20 000	52	106	0.108	1.5	0.0023	0.0017
TF313 TFHS313	500	200%	0.1% ^{b)}	15 000 20 000	59	850	0.034	1.9	0.0046	0.0034
TF314 TFHS314	1000	200%	0.1% ^{b)}	15 000 20 000	59	1285	0.045	2.0	0.0047	0.0035
TF315 TFHS315	2000	200%	0.1% ^{b)}	12 000 15 000	79	2476	0.046	3.2	0.0111	0.0082
TF316 TFHS316	5000	200%	0.1% ^{b)}	10 000 12 000	95	5573	0.051	5.0	0.0252	0.0186
TF317 TFHS317	10000	150% ^{e)}	0.1% ^{b)}	10 000 12 000	95	6 141	0.093	6.0	0.0276	0.0204
TF318	20000	200%	0.1-0.2%	3500	200	44 000	0.026	56.0	1.3430	0.9911
TF319	50000	180% ^{e)}	0.1-0.2%	3500	200	74 700	0.038	59.0	1.3790	1.0177
TF320	100000	180% ^{e)}	0.1-0.2%	3500	200	1047 000	0.055	63.5	1.3970	1.0310

Maximum Dynamique Torque without Damage (Overload Limit)

400% of Rated Torque

ENVIRONMENT

Rated Temperature Range	+10 °C ... +85 °C
Storage Temperature Range	-25 °C ... +85 °C
Extended Temperature Range (option)	-30 °C ... +125 °C
Temperature influence on zero	0.01% / °C
Protection class	IP42 (option IP54 & IP65) ^{g)}

ELECTRICAL CHARACTERISTICS

Power Supply	24 VDC ±10%, max 350mA TF 318, TF 319 & TF 320: 100-240 VAC
Torque Output Signal (rated / max.)	±5 VDC / ±10 VDC
Filter Bandwidth	0 ... 1 kHz (-3 dB) / (option 5 kHz)

SPEED MEASUREMENT (OPTION)

Number of Theeth	Depending on TF size; refer to number of teeth
Speed Pick-Up Transducer	Magneto-resistive
Minimum Speed Detection	< 1 rpm
Speed Output	TTL (Pulse Per Revolution correspond with number of teeth)

- a) Torque up to 150kN·m or higher, and high speed versions are available on request.
- b) Linearity- hysteresis error 0.05% is available on request.
- c) Inductive speed detection is available on request.
- d) Add 0.8...2.8kg to weight (depending on configuration), for electronic devices attached to the sensor (HF transmitter, receiver, speed conditioner,...)
- e) Dynamique torque peak values are due to force transmission limit of mounting screws.

- f) The X axis of the moment of inertia represents the rotation axis of the torque transducer (see Fig. 2).
- g) With IP54 & IP65, the combined error for models TF309 - TF312 is degraded; it will be 0.15% instead of 0.1%.

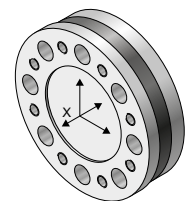
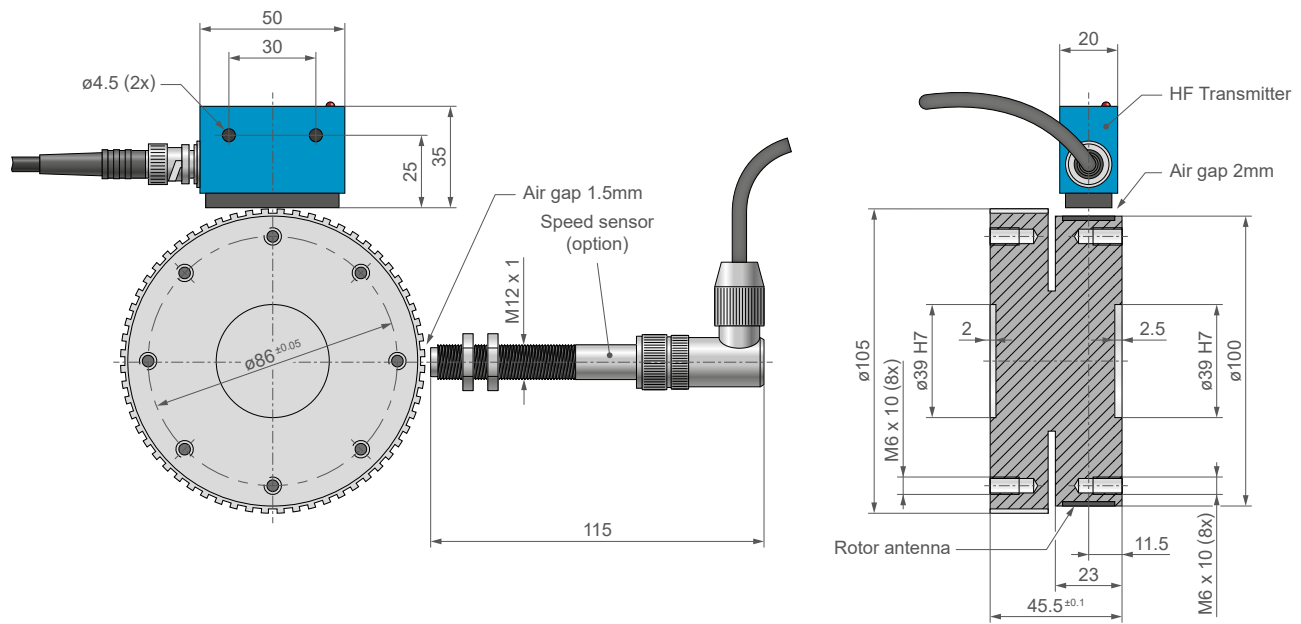

Fig. 2: Moment of Inertia (X Axis)

DATASHEET

DIMENSIONS TF & TFHS 309 - 312



DIMENSIONS TF & TFHS 313 - 317

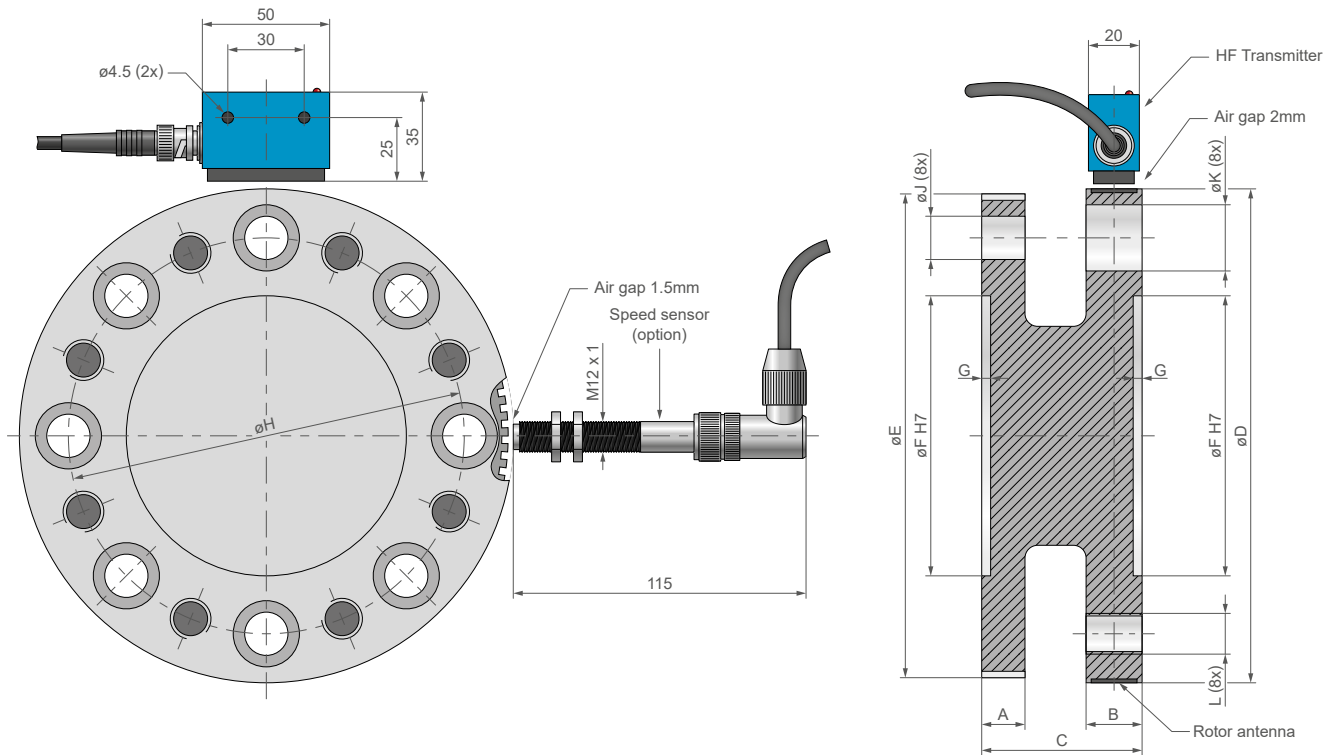

MODEL	A	B	C	øD	øE	øFH7	G	øH	øJ (8x)	øK (8x)	L (8x)	
TF/TFHS313	12	22	49	130	126	75	3.0	101.5±0.05	10.5	18	M10	
TF/TFHS314			53	164	156	90	3.5	130.0±0.05	12.5	20	M12	
TF/TFHS315			63	194	190	110	3.5	155.5±0.1	15.0	23	M14	
TF/TFHS316			14	17	26							
TF/TFHS317			17	26								

NOTE: All dimensions are in metric units.

NOTE: 3D STEP files of most of our products are available on our website: www.magtrol.com ; other files are available on request.

DIMENSIONS TF 318 - 319

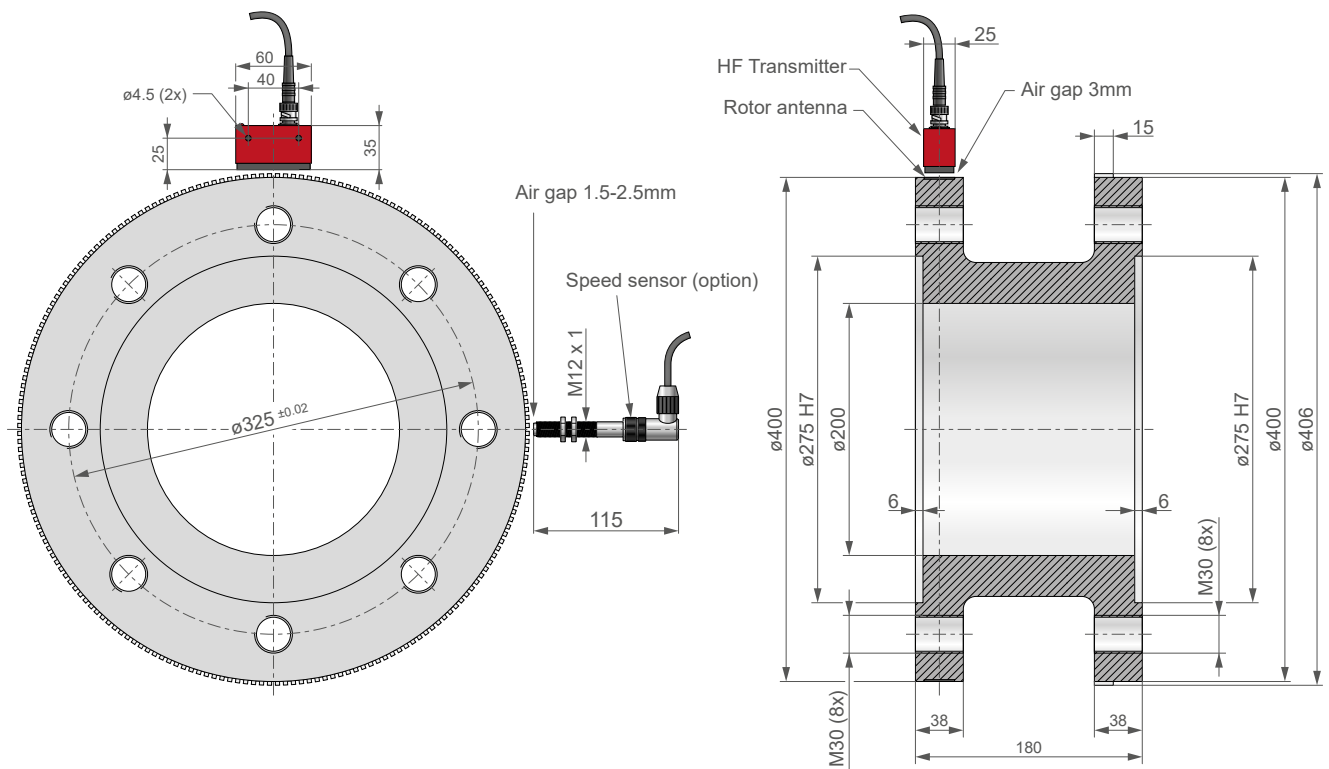

DIMENSIONS TF 320

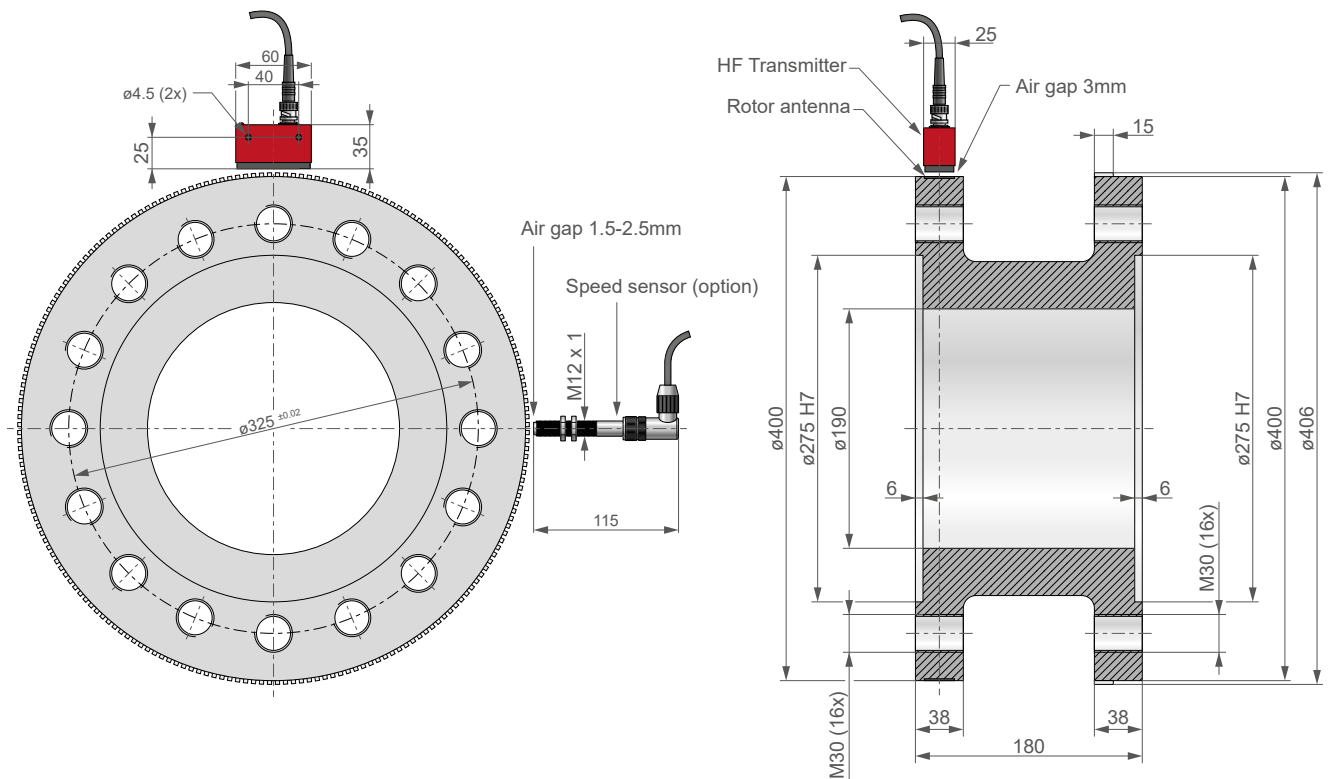

NOTE: All dimensions are in metric units.

NOTE: 3D STEP files of most of our products are available on our website: www.magtrol.com ; other files are available on request.

STANDARD SPEED SENSOR

The standard speed sensor is delivered with TF 300 Torque Flange Sensors ordered with the speed measurement option.

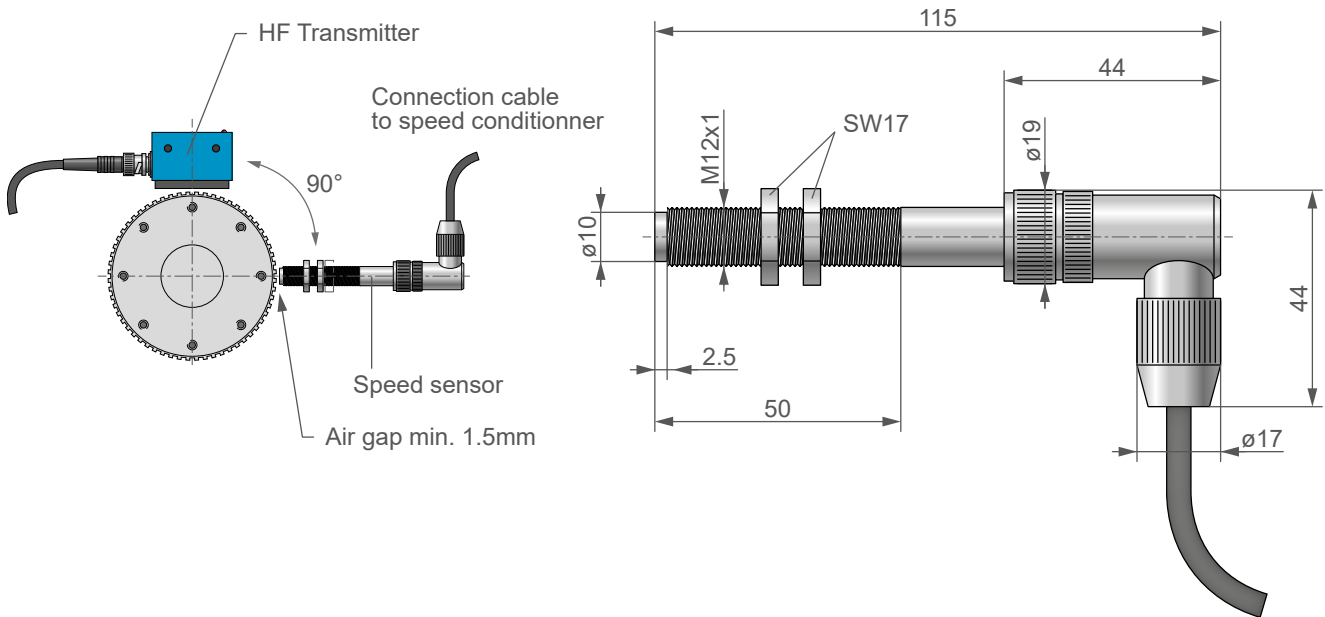

HIGH TEMPERATURE SPEED SENSOR

The high-temperature speed sensor is delivered with TF 300 Torque Flange Sensors ordered with both the speed measurement and extended temperature range options (125 °C).

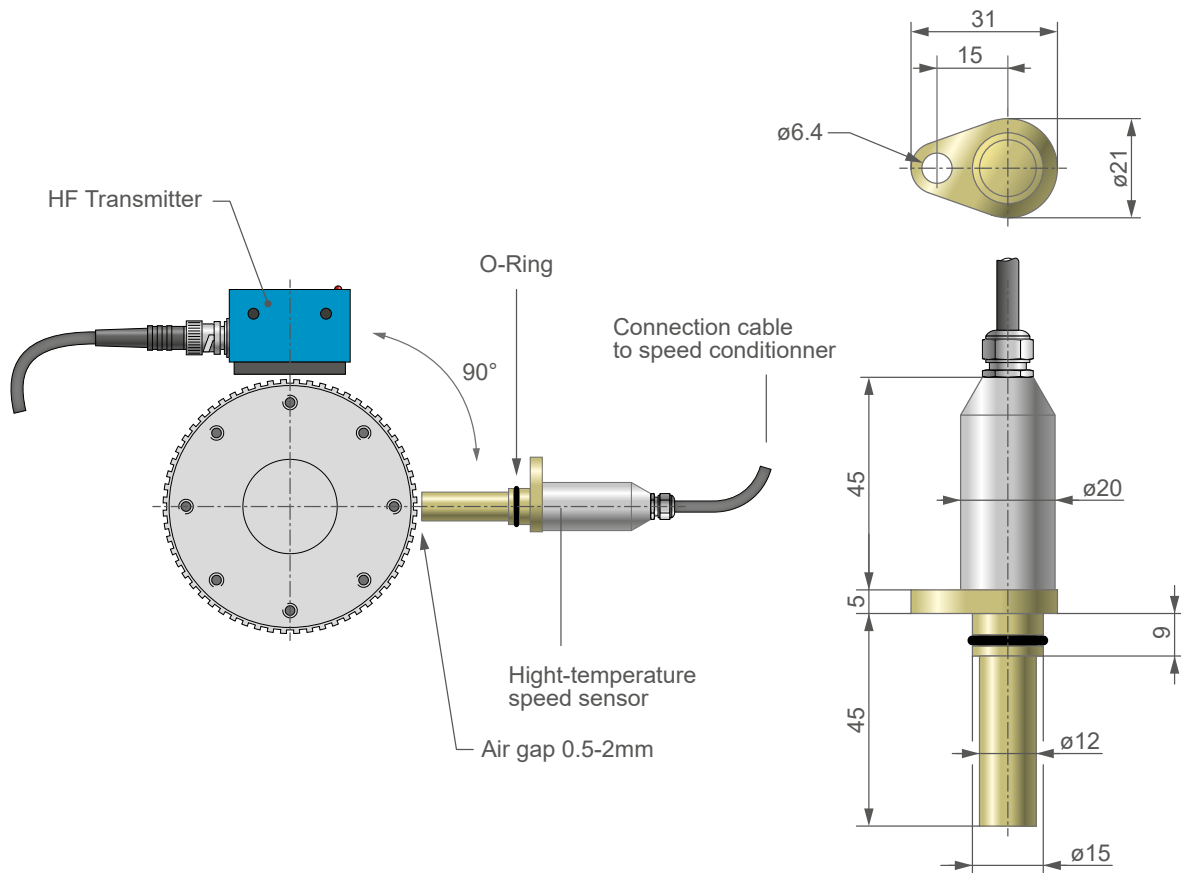

NOTE: All dimensions are in metric units.

NOTE: 3D STEP files of most of our products are available on our website: www.magtrol.com ; other files are available on request.

TORQUE SIGNAL CONDITIONER

Conditioner (1.5W) for TF 309...TF 317

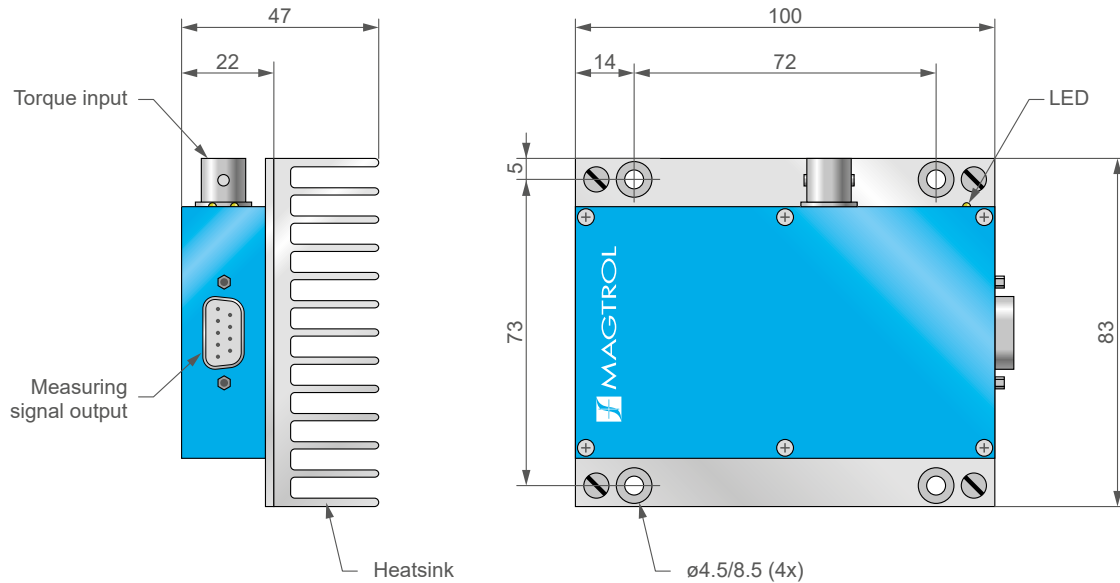

TORQUE SIGNAL CONDITIONER WITH SPEED OPTION

Conditioner (1.5W) with speed option for TF 309... TF 317

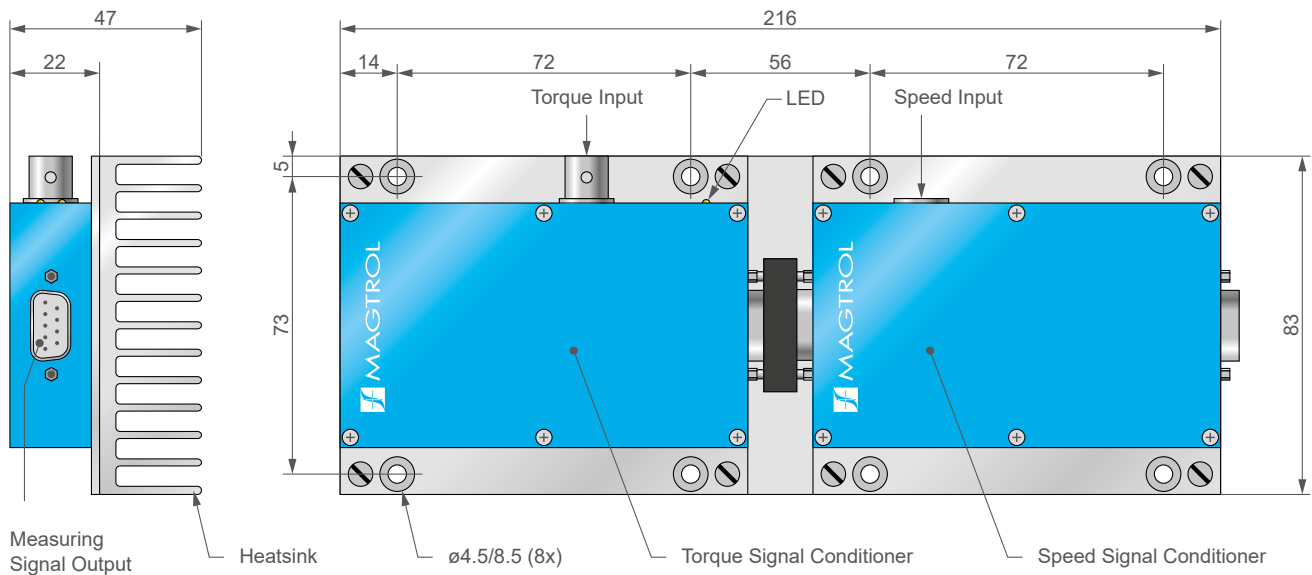

NOTE: All dimensions are in metric units.

NOTE: 3D STEP files of most of our products are available on our website: www.magtrol.com ; other files are available on request.

TORQUE SIGNAL CONDITIONER FOR TF 318-320

Conditioner with speed (5W), for TF318 ... TF320

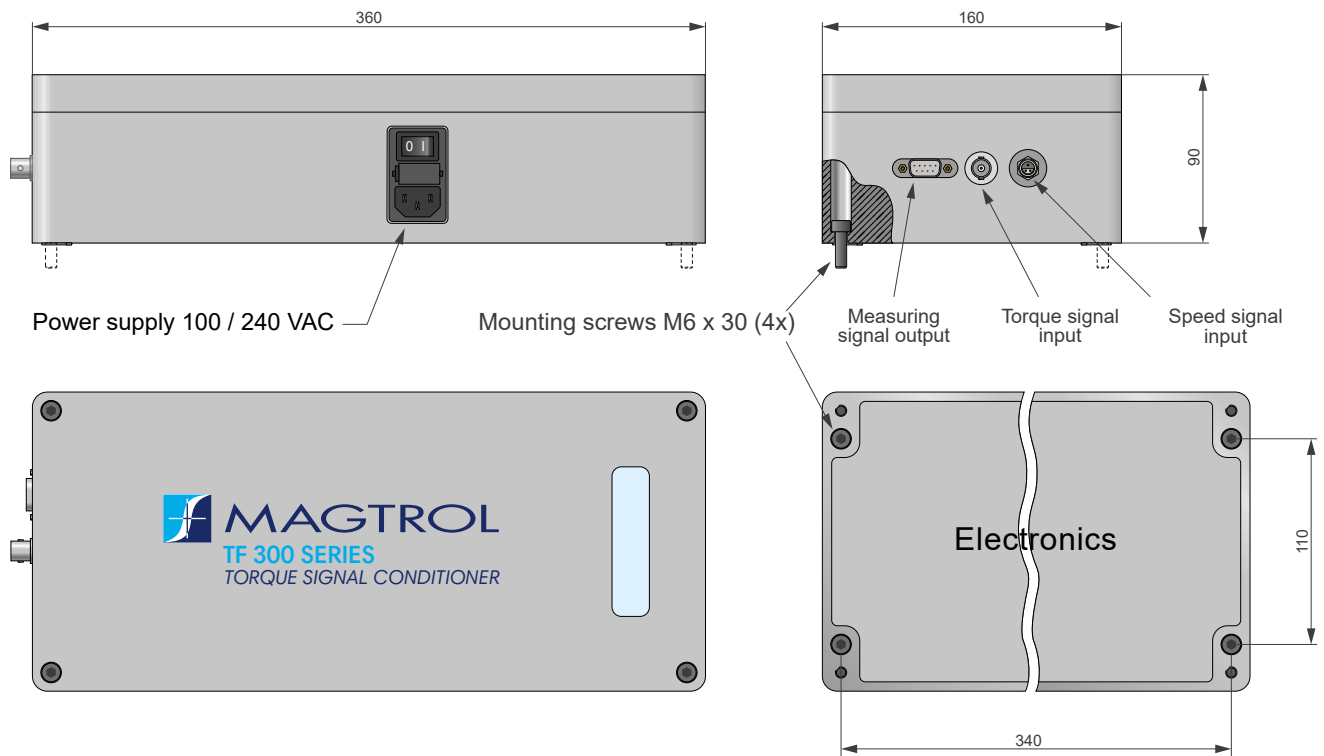

NOTE: All dimensions are in metric units.

NOTE: 3D STEP files of most of our products are available on our website: www.magtrol.com ; other files are available on request.

SYSTEM OPTIONS

MODEL 3411 - TORQUE DISPLAY

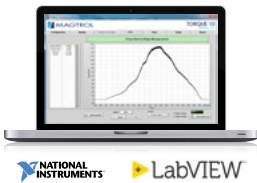

Fig. 3: MODEL3411 | Torque Display

Magtrol offers the MODEL3411 Torque Display which supplies power to any TF Sensor and displays torque, speed and mechanical power. Features include:

- Adjustable English, metric and SI torque units
- Large, easy-to-read vacuum fluorescent display
- Built-in self-diagnostic tests (B.I.T.E.)
- Overload indication
- Tare function
- USB & Ethernet interface
- Torque and speed outputs
- Closed-box calibration
- Includes Magtrol's TORQUE Software

«TORQUE» SOFTWARE



Magtrol's TORQUE Software is an easy-to-use Windows® executable program, used to automatically collect torque, speed and mechanical power data. The data can be printed, displayed graphically or quickly saved as a Microsoft® Excel spreadsheet. Standard features of Magtrol's TORQUE Software include: peak torque capture, multi-axes graphing, measured parameter vs. time, adjustable sampling rates and polynomial curve fitting.

CABLE ASSEMBLY

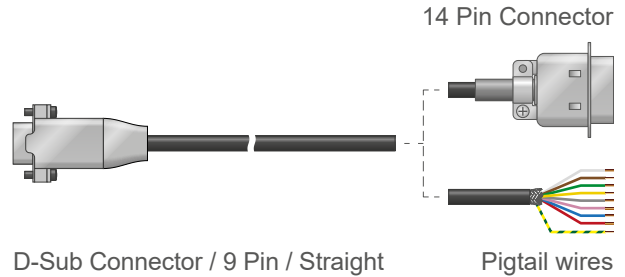

ORDERING NUMBER	ER 1	--	- 0	--
16	: 14 Pin connector ^{a)}			
17	: Pigtail wires			
1	: Cable lenght 5 m			
2	: Cable lenght 10 m			
3	: Cable lenght 20 m			

a) For use with MODEL 3411 Torque Display or DSP Controller

COUPLINGS

For our TF Torque Flange Sensors, Magtrol offers specific couplings KTF Series (flexible disc) or BKCTF Series (below type). For more details, please contact your regional sales office.



Fig. 4: KTF Series | Flexible Disc Coupling

ORDERING INFORMATIONS

ORDERING NUMBER	TF	--	---	/ X	--	X
HS	: for High Speed version					
309, 310, ..., 320	: Model TF or TFHS					
1	: Basic					
2	: With Speed Measurement					
5	: High Temperature version (up to 125 °C)					
6	: Speed Measurement & Hight Temperature (up to 125 °C)					

Example: TF312 Torque Flange Sensor, high speed version, with speed measurement, would be ordered as: **TFHS 312/X2X**.