

N.b. ROD-EYE ORIENTATION NOT GUARANTEED.

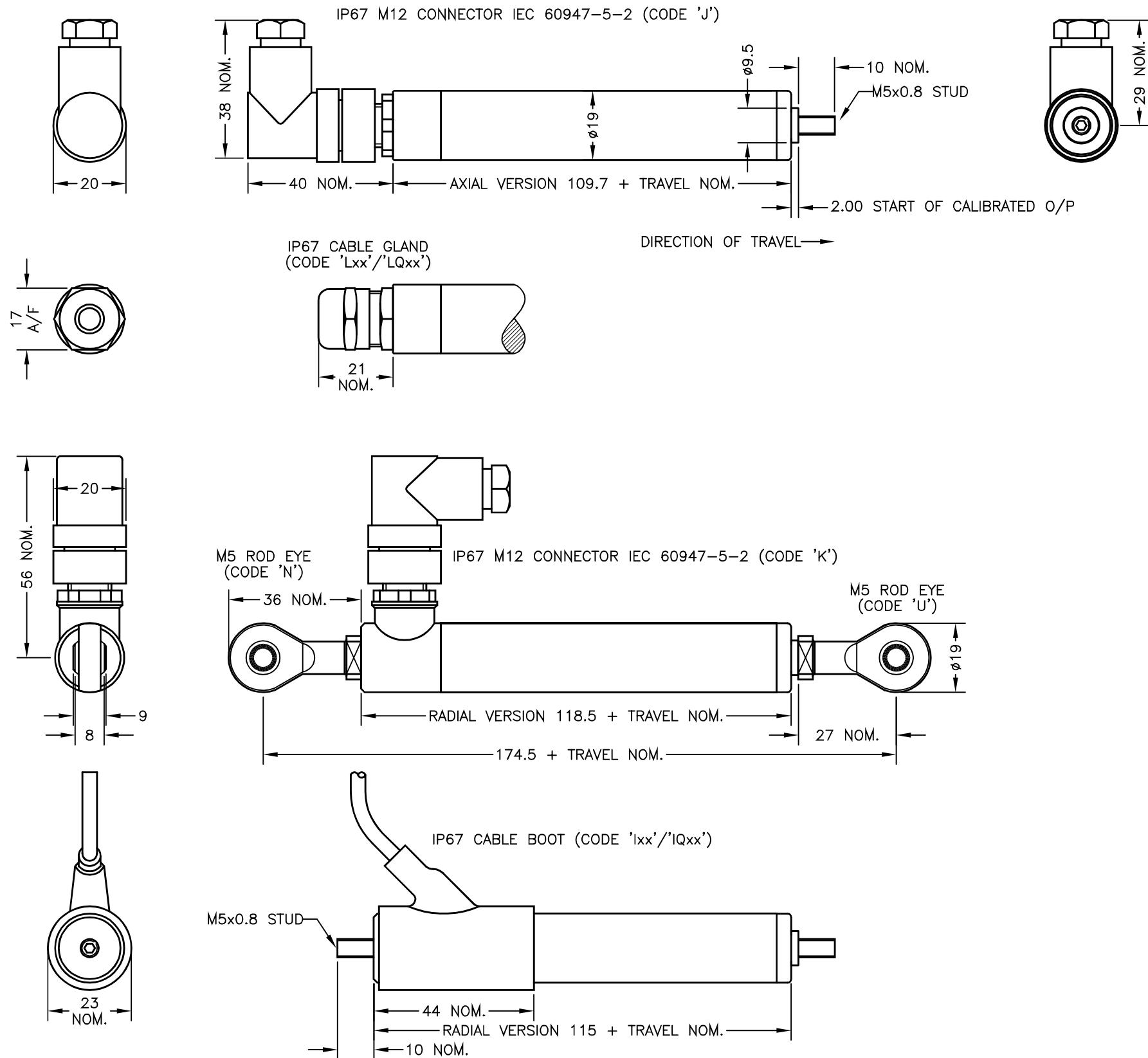

ELECTRICAL OPTIONS/ SPECIFICATIONS

OUTPUT	SUPPLY
0.5 TO 4.5V RATIOMETRIC	5V
SUPPLY CURRENT 12mA TYP. 20mA MAX.	

CABLE: 0.2mm², O/A SCREEN, PUR JACKET - SUPPLIED WITH 50cm OR REQUIRED LENGTH IN cm (15000cm MAX).
 STANDARD 3-CORE: JACKET Ø4mm BLACK e.g. 'L50'
 OPTIONAL 5-CORE: JACKET Ø4.6mm BLUE e.g. 'LQ50'

CABLE/CONNECTOR* CONNECTIONS;

3 CORE	5 CORE	CONNECTOR	
RED	RED	:1	+Ve
-	ORG	:1	+SENSE (5-WIRE ONLY)
BLACK	BLACK	:3	0V
-	GRY	:3	-SENSE (5-WIRE ONLY)
WHITE	WHITE	:2	OUTPUT
SCREEN	SCREEN	:4	BODY

*CONNECTORS; MAXIMUM CONDUCTOR CROSS SECTION 0.75mm²
 RANGE OF DISPLACEMENT FROM 0-5mm TO 0-350mm e.g.76, IN INCREMENTS OF 1mm.

BODY MATERIAL: STAINLESS STEEL.

FURTHER OPTIONS:

- SINGLE PAIR OF BODY CLAMPS 'P'
- TWO PAIRS OF BODY CLAMPS 'P2'
- PUSH-ROD FREE (CODE 'V')

NOTE:- READ INSTALLATION SHEET X117-19 FOR FULL INSTRUCTIONS FOR USE.

ATEX / IECEx APPROVED TO
II 1G
Ex ia IIC T4 Ga (Ta= -40° to +80°C)
Ui 11.4V, Ii 0.2A, Pi 0.51W

APPROVED FOR USE IN CONJUNCTION WITH A GALVANICALLY ISOLATED BARRIER.

NOTE: APPROVAL ONLY APPLIES AT NORMAL ATMOSPHERIC PRESSURE!

E	APPROVAL STANDARDS UPDATED - RAN465.	PDM
F	BODY CLAMP OPTIONS ADDED - RAN505.	PDM
G	RANGE WAS 10-350mm	RAN1056
H	PUSH-ROD DIA. ADDED ~ RAN1083	PDM
J	5-CORE OPTION ADDED ~ RAN1102	PDM
K	RANGE NOTE AMENDED ~ RAN1200	PDM



THE PUSH-ROD RETRACTS AND EXTENDS 2mm NOM. AT EITHER END OF CALIBRATED TRAVEL.
 'V' CODED PUSH-ROD WILL DEPART SENSOR BODY.

DRAWINGS NOT TO BE CHANGED WITHOUT REFERENCE TO THE CHANGE PROCEDURE.
 CHANGES TO PARTS USED IN INTRINSICALLY SAFE PRODUCT MUST BE APPROVED BY THE AUTHORISED PERSON
 THIS IS AN UNCONTROLLED PRINT AND WILL NOT BE UPDATED.

E	11/03/14		CHECKED BY	X	±0.4
F	25/07/14		RDS	X.X	±0.2
G	9/11/15			X.XX	±0.1
H	13/04/16	DESCRIPTION			
J	26/04/17	X117 INTRINSICALLY SAFE			
K	06/09/17	SLIM-LINE LINEAR POSITION SENSOR			
SCALE		DRAWING NUMBER		REV	
12.5mm		X117-11		K	
		SHEET		OF	
		1		1	