

RIPS[®] X520 SUBMERSIBLE ROTARY SENSOR

INTRINSICALLY SAFE FOR HAZARDOUS GAS/VAPOUR ATMOSPHERES

- Intrinsically safe for Gas:
Ex II 1G
- Non-contacting inductive technology to eliminate wear
- Angle set to customer's requirement
- Durable and reliable
- High accuracy and stability
- Pressure balanced for use to 350 Bar in under water applications



As a leading designer and manufacturer of linear, rotary, tilt and intrinsically safe position sensors, Positek[®] has the expertise to supply a sensor to suit a wide variety of applications.

Our X520 RIPS[®] (Rotary Inductive Position Sensor) incorporates electronics system EX07 which is ATEX / IECEx approved for use in potentially explosive gas/vapour atmospheres.

The X520 is designed to provide feedback for arduous underwater applications, such as ROVs, where hazardous surface conditions may exist. The X520, like all Positek[®] sensors, is supplied with the output calibrated to the angle required by the customer, between 15 and 160 degrees and with full EMC protection built in. The sensor provides a linear output proportional with input shaft rotation. There is a machined registration mark to identify the calibrated mid point.

Overall performance, repeatability and stability are outstanding over a wide temperature range. The X520 has long service life and environmental resistance with a rugged 316 stainless steel body and shaft, The flange mounting makes the sensor easy to install. There are a range of electrical options. Environmental sealing is to IP68 350Bar.

SPECIFICATION

Dimensions	
Body Diameter	60 mm, Flange 92 mm
Body Length	70 mm to mounting face
Shaft	15 mm Ø 6 mm
For full mechanical details see drawing X520-11	
Power Supply	+5V dc nom. ± 0.5V, 10mA typ 20mA max
Output Signal	0.5-4.5V dc ratiometric, Load: 5kΩ min.
Independent Linearity	≤ ± 0.25% FSO @ 20°C - up to 100° travel ≤ ± 0.1% FSO @ 20°C available upon request.
*Sensors with calibrated travel up to 100°.	
Pressure Effects	Output changes with pressure < 1°
Temperature Coefficients	< ± 0.01%/°C Gain & < ± 0.01%FS/°C Offset > 10 kHz (-3dB)
Frequency Response	
Resolution	Infinite
Noise	< 0.02% FSO
Torque	< 20 mNm Static
Intrinsic Safety	Ex II 1G Ex ia IIC T4 Ga (Ta= -40°C to 80°C)
Approval only applies to the specified ambient temperature range and atmospheric conditions in the range 0.80 to 1.10 Bar, oxygen ≤ 21%	
Sensor Input Parameters	Ui: 11.4V, Ii: 0.20A, Pi: 0.51W.
(without cable)	Ci: 1.16µF, Li: 50µH
(with cable)	Ci: 1.36µF, Li: 860µH with 1km max. cable
Environmental Temperature Limits (Non Icing)	
Operating	-4°C to +50°C
Storage	-4°C to +50°C
Sealing	Sealed to 350 Bar
EMC Performance	EN 61000-6-2, EN 61000-6-3
Vibration	IEC 68-2-6: 10 g IEC 68-2-29: 40 g
Shock	350,000 hrs 40°C Gf
MTBF	
Drawing List	
X520-11	Sensor Outline
Drawings, in AutoCAD [®] dwg or dxf format, available on request.	

Do you need a position sensor made to order to suit a particular installation requirement or specification? We'll be happy to modify any of our designs to suit your needs - please contact us with your requirements.

RIPS® X520 SUBMERSIBLE ROTARY SENSOR

INTRINSICALLY SAFE FOR HAZARDOUS GAS/VAPOUR ATMOSPHERES

Intrinsically safe equipment is defined as "equipment which is incapable of releasing sufficient electrical or thermal energy under normal or abnormal conditions to cause ignition of a specific hazardous atmosphere mixture in its most easily ignited concentration."

ATEX / IECEx approved to;
 Ex II 1G
 Ex ia IIC T4 Ga (Ta = -40°C to +80°C)

Designates the sensor as belonging to; Group II: suitable for all areas **except mining**, Category 1 G: can be used in areas with continuous, long or frequent periods of exposure to hazardous gas (Zone 0).

Protection class ia, denotes intrinsically safe for all zones Apparatus group IIC: suitable for IIA to IIC explosive gas. Temperature class T4: maximum surface temperature under fault conditions 135°C.

Ambient temperature range extended to -40°C to +80°C.

It is imperative Positek® intrinsically safe sensors be used in conjunction with a galvanic barrier to meet the requirements of the product certification. The Positek X005 Galvanic Isolation Amplifier is purpose made for Positek IS sensors making it the perfect choice. Refer to the X005 datasheet for product specification and output configuration options.

Safety Parameters:-

Ui: 11.4V, Ii: 0.20A, Pi: 0.51W
 Ci = 1.36µF* Li = 860µH* (with cable)
 Ci = 1.16µF Li = 50µH (without cable)

*Figures for 1km cable where: Ci = 200pF/m & Li = 810nH/m

Sensors can be installed with a maximum of 1000m of cable.

Cable characteristics must not exceed:-

Capacitance: ≤ 200 pF/m for max. total of: 200 nF.
 Inductance: ≤ 810 nH/m for max. total of: 810 µH

For cable lengths exceeding 10 metres a five wire connection is recommended to eliminate errors introduced by cable resistance and associated temperature coefficients.

TABLE OF OPTIONS

CALIBRATED TRAVEL: Factory-set to any angle from ±7.5° to ±80° in increments of 1 degree.

Full 360° Mechanical rotation.

ELECTRICAL INTERFACE OPTIONS

The Positek® X005 Galvanic Isolation Amplifier is available with the following output options;

Standard: 0.5 - 9.5V or 4 - 20mA.

Reverse: 9.5 - 0.5V or 20 - 4mA.

CONNECTOR

Wet mate 4 pin MC BH-4-M

Supplied with a connector and 0.5 m, 4x0.5mm² cable assembly as standard.

Mating connector with longer lengths available.

We recommend all customers refer to the 3 or 5-Wire Mode Connection page.

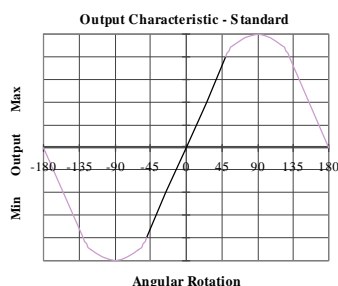

Three or Five-Wire Mode Connection FOR INTRINSICALLY SAFE SENSORS IN HAZARDOUS ATMOSPHERES

The aim of this document is to help readers who do not understand what is meant by three or five wire modes of connection between the galvanic isolation amplifier and sensor, and the factors behind them. It is by no means an in-depth technical analysis of the subject.

Interconnecting cables are not perfect conductors and offer resistance to current flow, the magnitude of resistance[†] depends on conductors resistivity, which changes with temperature, cross sectional area[‡] and length. If the voltage were to be measured at both ends of a length of wire it would be found they are different, this is known as volts drop. Volts drop changes with current flow and can be calculated using Ohm's law, it should be noted that volts drop occurs in both positive and negative conductors. The effects of volts drop can be reduced by increasing the conductors cross sectional area, this does not however eliminate the effects due to temperature variation. There are situations where large cross-section cables are not practical; for example copper prices and ease of installation.

This is important because the effects of volts drop can significantly alter the perceived accuracy of the sensor which is ratiometric i.e. the output signal is directly affected by the voltage across the sensor. Changes in temperature will also be seen as gain variation in the sensor output.

Three wire mode connections are common and are suitable in most cases with short or moderate cable runs. Applications that do not require a high degree of accuracy but have cable runs, say in excess of 20m, volts drop can be reduced by introducing a terminal box close to the sensor and using a larger cross-section cable for a majority of the cable run. Sensors are supplied calibrated via a wet mate connector and cable assembly which largely eliminates errors due to conductor resistance at room temperature however, as mentioned above, small gain errors due to temperature fluctuations should be expected.

Five wire mode connections have significant benefits as losses in the positive and negative conductors are compensated for by the galvanic isolation amplifier which can 'sense' the voltage across the sensor and dynamically adjust the output voltage so that the voltage across the sensor is correct. The effects of cable resistance and associated temperature coefficients are eliminated allowing for smaller conductors than a three wire connection for the same cable run. The amplifier can compensate for up to 15Ω per conductor with a current flow of 15mA, which is more than adequate for 300m of 0.5 mm² cable, longer lengths will require larger conductors.

For this reason Positek® recommends five wire connections for cable lengths exceeding 20 metres in 0.5 mm² cable to preserve the full accuracy of the sensor.

Positek® submersible sensors are supplied with a wet mate connector and four core 0.5 mm² cable assembly as standard.

See illustrations below for examples of connecting a sensor to the galvanic isolation amplifier.

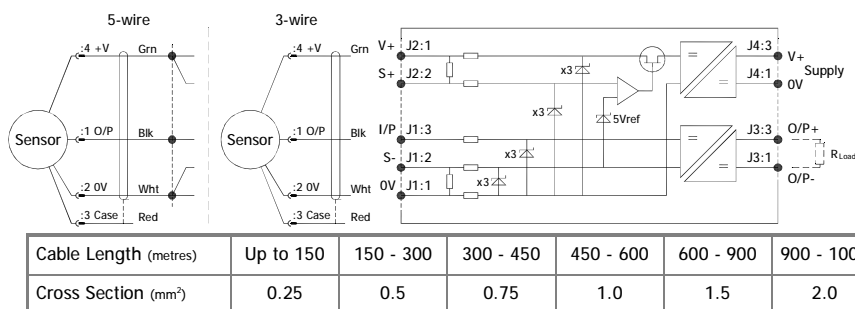

The table above shows recommended conductor sizes with respect to cable length for both three and five wire connections, based on copper conductors. Three wire connections will introduce a gain reduction of 5% and a ±1% temperature dependence of gain over the range -40°C to +80°C for the cable temperature. (i.e. about -150 ppm/°C for the maximum lengths shown and less pro rata for shorter lengths.)

It should be noted that the maximum cable length, as specified in the sensor certification, takes precedence and must not be exceeded.

The galvanic isolation amplifier is available as;

G005-*** for 'G' prefix sensors
 X005-*** for 'X' prefix sensors

[†] $R = \rho L/A$ ρ is the resistivity of the conductor (Ωm) L is the length of conductor (m) A is the conductor cross-sectional area (m²).

[‡] It is presumed that direct current flow is uniform across the cross-section of the wire, the galvanic isolation amplifier and sensor are a dc system.

Intrinsically Safe - Gas/Vapour Atmospheres

RIPS® SERIES X520 Submersible Rotary Sensor

	a	b	c	d
X520 .	Displacement	A	K50	Z-code

a Displacement (degrees)		Value
Displacement in degrees	e.g. 0 - 54 degrees	54
b Output		
Supply V dc V _s (tolerance)	Output	Code
+5V (4.5 - 5.5V)	0.5 - 4.5V (ratiometric with supply)	A
c Connections		Code
Connector	IP68 350 Bar Wet mate 4 pin MC BH-4-M plus pre-wired mating connector with 50 cm 4-core cable.	K50
d Z-code		Code
Calibration to suit X005 - Default		Z000
≤± 0.1% @20°C Independent Linearity displacement up to 100 degrees only!		Z650

Note!

All Intrinsically Safe (IS) sensors must have a Z-code suffix.

IS sensors must be used in conjunction with a Galvanic Isolation Amplifier - See X005 for Output options.