

# CUSTOM MANUFACTURED LOAD MEASURING PINS

*diameters from 20mm to 250mm, capacities up to 1000 tonnes*



Strain gauged load pins can easily replace an existing clevis, pivot pin or solid shafts in machinery or equipment to measure the load at that point. They are used in many diverse applications including cranes, winches, agricultural equipment (such as tractors), fishing, marine, offshore, subsea, aerospace, process industries, mining, hoisting gear, elevators and floor conveyors, cable laying machinery and many others. The load information provided by the pin can be used for process control, weight/force measurement, overload protection and safety related aspects.

All Thames Side Sensors load pins are manufactured from special grades of stainless steel which are hardened to produce the best compromise between metrological and strength requirements.

- Custom manufactured to replace existing pins normally without changes to the mechanical structure.
- Robust construction in high strength stainless steel with optional material certificate to EN 10204 3.1B
- Choice of locking systems to suit the application
- Fast delivery with 3D CAD drawings supplied for approval prior to manufacturing
- Externally gauged for IP66 or internally gauged for IP68 performance
- Working temperature from -20°C to +90°C
- High temperature option up to 180°C
- Optional integrated amplifier for analogue outputs
- Single or dual output
- ATEX option

A load pin works by measuring the shear force applied across it using strain gauges bonded to the pin body in a Wheatstone bridge configuration to generate a mV/V signal. Load pins are usually designed to measure the force in one direction only, normally at right angles to the pin. Forces along the pin axis will not be measured.

Load pins usually operate in a double shear mode, with both ends of the pin supported.

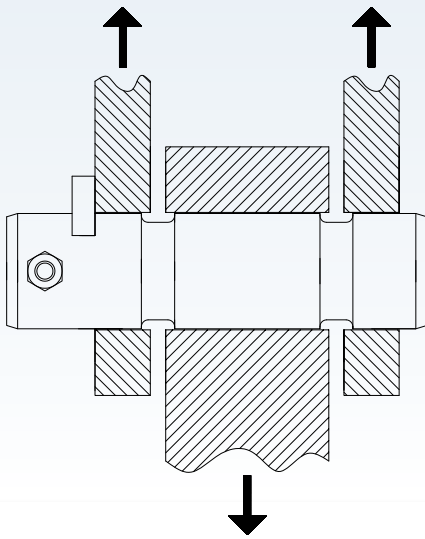

Special high strength stainless steels are used to maximise the load bearing capacity of the pin.

Two basic types are available, generally known as internally and externally gauged pins.

## ACCURACY AND REPEATABILITY

Normally a load pin can be expected to perform with an accuracy of better than +/- 0.5% and a repeatability better than +/- 0.01% of its full range output however there are factors which can affect this including the rigidity of the mechanical structure where the pin is installed, the load to diameter ratio and the tolerances of the holes where the pin is installed. As the load pin works by measuring the shear force across it, any bending forces acting on the pin can affect its overall accuracy.

## INTERNALLY GAUGED PINS

Internally gauged pins are the most widely used type as they have a better IP rating (typically IP68). Strain gauges are mounted on the internal face of a small diameter internal borehole. The shear planes are defined by two machined grooves located on the external pin surface in the area where the force is being measured.



## EXTERNALLY GAUGED PINS

Externally gauged pins are more cost effective as the manufacturing process is simpler. The strain gauges are mounted in 'gauge pockets' on the external diameter of the pins centrally in the two machined grooves. Due to the external sealing of the gauges the IP rating is lower (typically IP66)



## HIGH TEMPERATURE PINS

Load pins can be supplied for high temperature applications up to 180C and incorporate special strain gauges and electrical components together with a 'Teflon' PTFE cable with either a cable gland or high temperature rated connector.



## CABLE AND CONNECTORS

The polyurethane cable which carries the signal can normally exit the load pin to suit the installation and space requirements. Care should be taken to protect the cabling system from accidental damage during installation or operation. A plug and socket arrangement can be provided if required although 'hard wired' pins are more robust as cable connectors can become damaged or worn.

LOAD PIN ARRANGEMENTS - CABLE OUTLETS

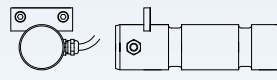

Radial Cable Outlet

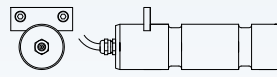

Axial Cable Outlet

LOAD PIN ARRANGEMENTS - CONNECTOR OUTLETS

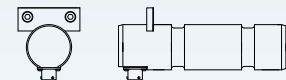

Radial Connector

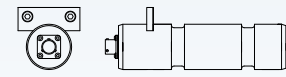

Axial Connector

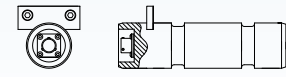

Recessed Connector

## LOCKING SYSTEMS

Load pins must be securely locked in position to ensure they do not turn or move laterally in the assembly so that accurate and repeatable measurements are produced. Various locking systems are used, including single or double keeper plates acting on grooves machined in the pin or anti-rotation plates with split pin or threaded nut on the end of the pin. Typical locking arrangement options are shown below;

LOAD PIN ARRANGEMENTS - SINGLE DIAMETER STYLE

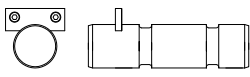

Single Keep Plate

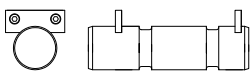

Dual Keep Plates

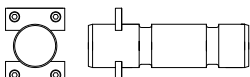

Dual Opposite Keep Plates

LOAD PIN ARRANGEMENTS - TERMINAL HOUSING STYLE

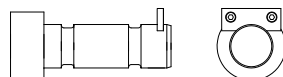

Single Keep Plate

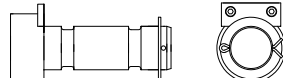

Single Keep Plate plus Split Pin & Washer.

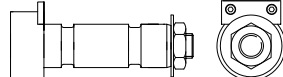

Single Keep Plate plus Nut & Washer.

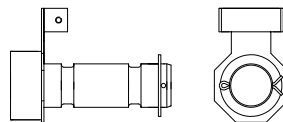

Anti-Rotation Bracket plus Split Pin & Washer.

## SIGNAL OUTPUTS

Load pins can be provided with a standard mV/V output for connection to a range of load transmitters/instrumentation, including Thames Side's own XT1000 or XT2000 high speed transmitters. The mV/V output will depend on the required safety factor and the pin dimensions and will typically be in the range between 1 and 2 mV/V. A built-in analogue amplifier to give a 4-20mA or 0-10V output can be supplied as an option.

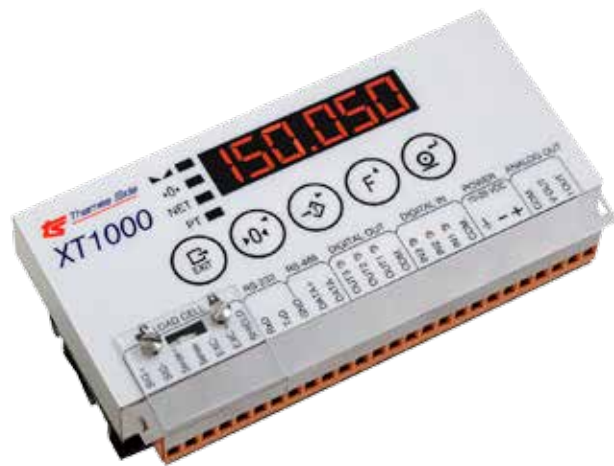

## LP CUSTOM MANUFACTURED LOAD MEASURING PINS

<b>Material of Construction</b>	High Strength Stainless Steel Material Certificate to EN10204 3.1B available on request
<b>Load Rating</b>	up to 1000t
<b>Minimum Dead Load</b>	0% of nominal load
<b>Safe Overload</b>	150% of nominal load
<b>Ultimate Overload</b>	≥400% of nominal load
<b>Rated Output</b>	1mV/V to 2mV/V +/-0.25%
<b>No Load Output</b>	< 2% *
<b>Excitation Voltage</b>	5-10V recommended 15V maximum
<b>Input Resistance</b>	400 +/-30Ω
<b>Output Resistance</b>	352 +/-5Ω
<b>Total Error</b>	< +/-0.5% *
<b>Repeatability Error</b>	< +/-0.1% *
<b>Temperature Effect on Zero</b>	< +/-0.02% * / 5°C
<b>Temperature Effect on Sensitivity</b>	< +/-0.02% * / 5°C
<b>Creep Error (30 minutes)</b>	< +/-0.1% *
<b>Temperature Compensation</b>	-20°C to +60°C
<b>Operating Temperature</b>	-20°C to +90°C (High temperature option for up to +180°C)
<b>Storage Temperature</b>	-40°C to +95°C
<b>Ingress Protection</b>	IP66 for externally gauged IP68 for internally gauged
<b>Connection</b>	Standard with cable gland Optional plug/socket connector
<b>Cable</b>	Standard 5m long polyurethane cable High temperature 5m long PTFE cable Custom cable lengths available
<b>Insulation Resistance</b>	>5000 MΩ

\*With respect to rated load

Standard Cable

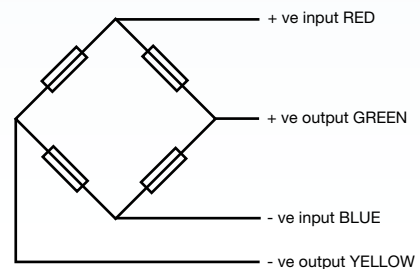

High Temperature Cable

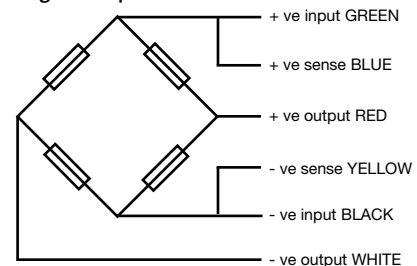

## THAMES SIDE SENSORS LTD

Issue: LP.08.15



DISTRIBUTED BY:

**DSPM Industria\***  
sensori & trasduttori

Via Paolo Uccello 4 - 20148 Milano  
Tel +39 02 48 009 757 Fax +39 02 48 002 070  
info@dspmindustria.it www.dspmindustria.it

