

# JX-HM4

# JX-HM5

# POSITION TRANSDUCER

# INSTALLATION GUIDE

## SPECIFICATIONS

Excitation Voltage.....4.9 to 30 VDC  
 Output Load ..... 10K ohm Min.  
 Protection ..... Reversed Polarity  
 Linearity ..... ±0.10% Full Scale  
 Operating Temperature.....-25°C to 75°C  
 Storage Temperature.....-50°C to 80°C  
 Ingress Protection ..... IP-67

## MOUNTING

To maximize wire rope life, align transducer with moving element so that wire rope exits perpendicular to axis of wire rope exit hole within 2° (See FIG 3)  
 Secure unit to mounting surface with two Ø0.25 inch or ØM6 bolts. Place flat washer under head of each bolt. Torque to 32 lb-in (3.6 N-m) maximum.

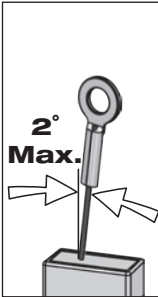

## DIMENSIONAL INFORMATION

### RANGE 150" (3.8 m)

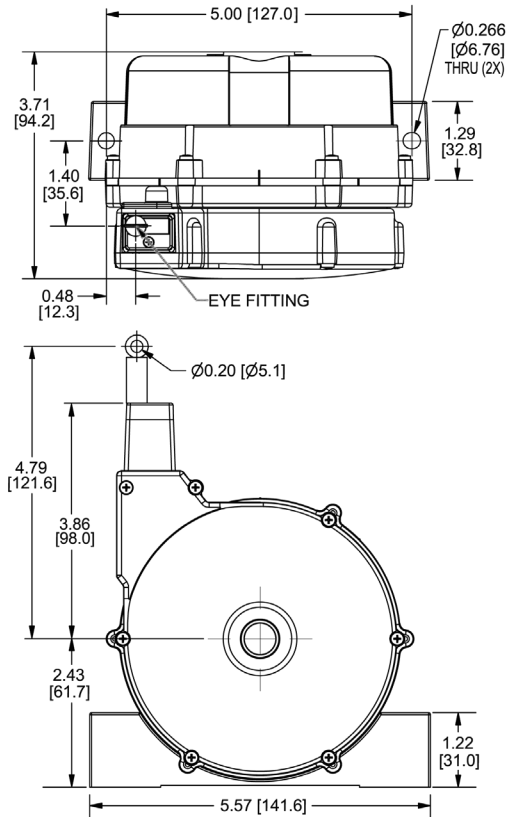
**FIG 1**

Dimensions in brackets are millimeters.

### RANGES 300" (7.5 m)

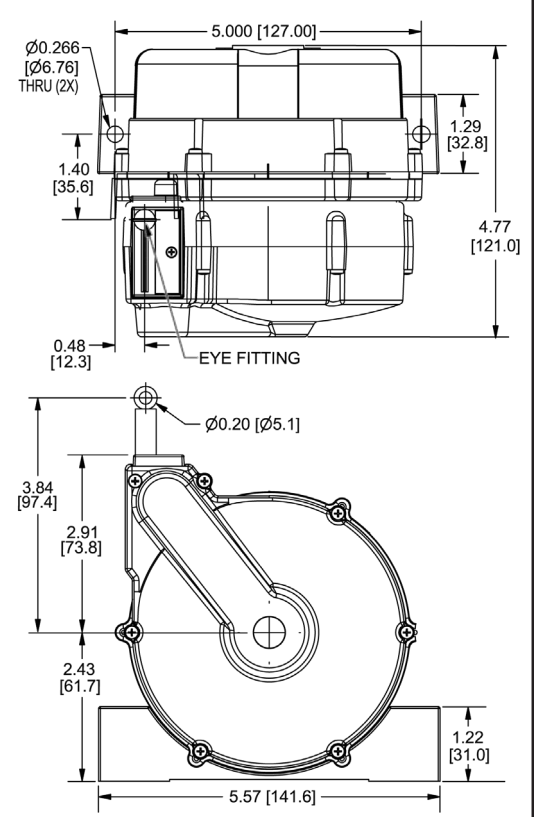
**FIG 2**

Dimensions in brackets are millimeters.

## ZERO, SPAN & DIP SWITCHES

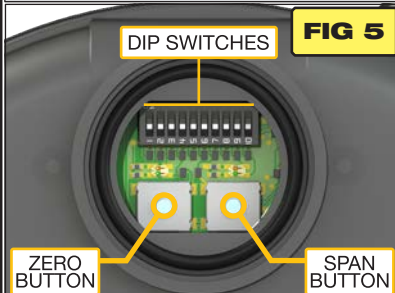

## CHANGING OUTPUTS

Referring to FIG 4, remove hatch using a blade type screwdriver. Using a small pointed object, referring to DIP SWITCHES in FIG 5 and output diagrams below, set dip switches to ON/OFF positions for desired output. **Note:** Dip switches 4 through 10 should all be in the OFF position.

### JX-HM4 4-20mA, 0-20mA

JX-HM4 may only be set to **CURRENT** outputs

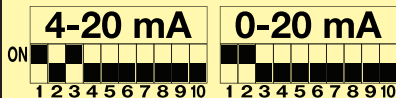

### JX-HM4 - SHIPS IN 4-20 mA MODE

### JX-HM5 0-10, 0-5, ±10, ±5 VDC

JX-HM5 may only be set to **VOLTAGE** outputs

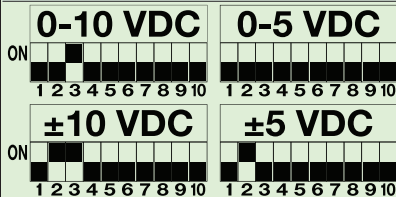

### JX-HM5 - SHIPS IN 0-10 VDC MODE



## ZERO & SPAN SETTINGS

Use FIG 4 & 5, to locate zero & span buttons.

### SETTING THE ZERO POSITION

- Extend wire rope to ZERO position.
- Press the ZERO button 2 times within 5 seconds to set the ZERO position. **NOTE:** LED will blink AMBER on 1st press of ZERO button & blink GREEN on 2nd press of ZERO button. ZERO is set when GREEN LED stops blinking.

### SETTING THE SPAN POSITION

- Extend wire rope to SPAN position.
- Press the SPAN button 2 times within 5 seconds to set the SPAN position. **NOTE:** LED will blink AMBER on 1st press of SPAN button & blink GREEN on 2nd press of SPAN button. SPAN is set when GREEN LED stops blinking.

### REVERSED OUTPUT

(Output decreases as wire rope is extended)  
 To set the unit up so that the output decreases as the wire rope is extended, extend the wire rope to the outbound position where the ZERO is desired. Set the ZERO position per the instructions 'Setting the zero position' above. For the SPAN position, extend the wire rope to the desired SPAN inbound position. Set the SPAN position per the instructions 'Setting the span position' above.

### ACCESS HATCH RE-INSTALL

With output selection and zero and span setting completed, re-install access hatch. Insure that o-ring seal is in place on hatch. Place hatch into hatch opening and rotate clockwise 1/4 turn with screwdriver.

## ACCESS HATCH

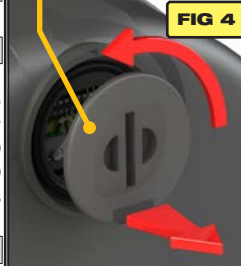

## OUTPUT RESOLUTION

The output resolution varies with range and is dependent upon both the internal encoding device and the outputting digital to analog converter. In ranges above 100" (2.5m), the resolution is approximately (Range/32000) although the observed resolution may be dependent upon the decimal precision of the interfacing electronics. Below 100" (2.5m), the resolution in inches is approximately 1/(Range\*341). Below 2.5m the resolution in mm is approximately 1/(Range in mm\*13.4).  
**Note:** the resolutions mentioned above are only approximate and will vary somewhat depending upon the type of output selected.

## ELECTRICAL CONNECTIONS

Per FIG. 6, in addition to +Vin and ±Vout (or Iout), the circuit diagram shows two COMMON lines that are connected together inside of the transducer. For the current output mode (4 to 20mA and 0 to 20mA) a 3 wire or 4 wire connection is acceptable without affecting output performance. For the four voltage output modes, a 4 wire connection is suggested. Otherwise, output values will be different for different input voltages. Factory calibration is done with a 4 wire connection.

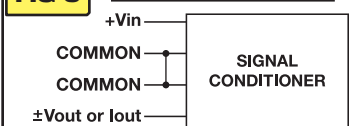
**FIG 6** ELECTRICAL CONNECTIONS

## MATING CONNECTOR

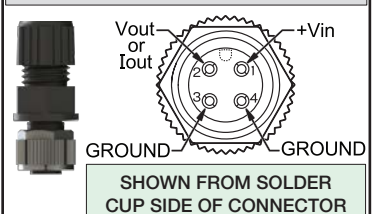

## ELECTRICAL CABLE

