



**Silicon Sensing UK copy of
Silicon Sensing Systems Japan Ltd.
originated**

Product Specification

for

CRS03-01 and CRS03-02 Rev 9

(Commercial Rate Sensor)
covering model variants:-

CRS03-01R

CRS03-01S

CRS03-02R

CRS03-02S

TITLE		DOC. NUMBER	REV.			
PRODUCT SPECIFICATION FOR SINGLE AXIS SILICON VIBRATING STRUCTURE GYRO CRS03-01R/02R /01S/02S		SST - 0015	9			
<p>NOTICE:</p> <p>User and/or Purchaser [Customer] shall indemnify and hold Silicon Sensing Systems Japan Limited ("SSSJL"), Silicon Sensing Systems Limited and its affiliates, including its members, shareholders, managers, directors, officers, employees, agents and representatives, harmless from and against any and all liabilities, claims, demands, actions, costs or expenses (including all reasonable legal or litigation costs), by whomever asserted and regardless of nature or kind, including without limitation and/or product liability claims arising from the use of any Gyro product supplied by SSSJL to [Customer], claims for personal injuries (including death) and damage to property, whether in tort or under contract, directly or indirectly, in whole or in part, attributed to or arising from the use by [Customer] of any Gyro product supplied by SSSJL to [Customer] for any purpose including but without limitation, installing the Gyro product on a product, equipment, or vehicle of any kind, or using the Gyro product for training or simulation purposes in relation to a product, equipment, or vehicle of any kind, or using the Gyro product for the support or maintenance of a product, equipment, or vehicle of any kind. SSSJL shall promptly notify [Customer] of any such claim for which indemnification will be sought. [Customer] shall have the right at its expense to assume and control the defence of such claims and SSSJL shall provide reasonable co-operation and information to [Customer] in order for [Customer] to defend the claims. [Customer] may not settle any such claim without the prior written consent of SSSJL, which consent may not be unreasonably withheld. Gyro product supplied by SSSJL is not warranted in any way for any period regardless of the existing laws and/or regulations unless agreed by and between SSSJ and [Customer] prior to purchasing. Applications that require extra reliability and quality possibly affecting the safety of living things (e.g. transport, combustion, security, etc.) or any applications which are thought to be beyond the focus of the product, should be consulted with SSS first. © Reproduction in any form prohibited. 禁無断転載 本書類の日本語部は参考用であり英語部を正とする。</p>						
9		Fig.1, Fig.2 Deleted with elimination of CRS03-01/02 Fig.3, Fig.5 Modified (CRS03-01R/01S)	'08.04.02 小 椎 山 松 卷 山 科 居			
8		P2 : Clear Notification of RoHS Compliance (CRS03-01S/02S)	'07.05.08 小 谷 山 松 卷 本 科 居			
S P P (M E M S) S S S U K S S P S S S J	7	P2 : Add an alternate ASIC model(CRS03-01S/02S). P2 : Mechanical Description revised P8,P9 : Add Fig.5, Fig.6	'06.08.01 小 山 山 川 卷 口 科 淵			
	6	P2 : Model Number revised (RoHs compliance) P2 : Mechanical Description revised P4,P5 : Fig.1, Fig.2 amended P6,P7 : Fig.3, Fig.4 added	'05.11.14 小 南 山 山 卷 南 科 口			
	5 (E)	P1 : Notice revised P2 : 4.Performance Current dissipation revised P4,P5 : Fig.1, Fig.2 amended	'04.04.20 小 南 山 中 卷 南 科 村 卓 山 口			
	4 (D)	P4,P5 : Fig.1, Fig.2 amended	'02.10.17 德 北 坂 中 江 村 本 村 卓			
	C	SCN-0197 Modify No. : SCN-0197 P1,P2	'01.10.01 德 北 坂 吉 江 村 本 岡			
	B	SCN-0151 Modify No. : SCN-0151 All pages	01.02.08 北 坂 吉 村 本 岡 辻			
	A	SCN-0104 Modify No. : SCN-0104 P1,P4,P5	'00.03.22 德 北 西 坂 江 村 尾 本			
REV.	MODIFY No	REVISED PAGES	DATE	CHECKED		
Silicon Sensing Systems Japan Ltd. 1-10 Fuso-cho, Amagasaki, Hyogo 660-0891 Japan Tel +81-6-6489-5868 Fax +81-6-6489-5910 E-Mail : sssj@spp.co.jp		DATE	APPROVED	CHECKED	PREPARED	
Total			'00.02.25	Tokue	Kitamura	Sakamoto Nishio



1. DESCRIPTION/概要

The silicon vibrating structure gyroscope (Si-VSG) is a solid state single axis rate sensor. It is a stand alone unit and dc output is proportional to the rate of rotation and supply voltage.

The new concept ring-shaped micro-machined resonator shows distinguished resistance against external shocks and vibrations over a wide range of temperature.

本シリコン振動ジャイロは1軸ソリッドステート角速度センサであり角速度と供給電圧に比例した直流電圧を出力する。マイクロマシニングのリング型振動子により広い温度範囲で外部衝撃や振動に対し優れた耐性を発揮するものである。

2. MODEL NUMBER/製品型名

CRS03 - 01R	Pin output range100deg/sec	ピン出力タイプ (RoHS compliance / RoHS対応品)
CRS03 - 02R	Connector output range100deg/sec	コネクタ出力タイプ (RoHS compliance / RoHS対応品)
CRS03 - 01S	Pin output range100deg/sec	ピン出力タイプ (GOA ASIC対応品,RoHS Compliance / RoHS対応品)
CRS03 - 02S	Connector output range100deg/sec	コネクタ出力タイプ (GOA ASIC対応品,RoHS Compliance / RoHS対応品)
CRS03	Basic Model Number	基本製品番号
-xxR	Design Number	タイプ識別番号(RoHS compliance / RoHS対応品)
-xxS	Design Number	タイプ識別番号(GOA ASIC対応品,RoHS Compliance / RoHS対応品)

3. MECHANICAL DESCRIPTION/外形

The nominal dimensions are shown in Fig.3,4,5,6.(Fig3,4 RoHS compliance Fig5,6 GOA ASIC model, **RoHS Compliance**)

図3,4,5,6を参照。(図3,4 RoHS対応品、図5,6 GOA ASIC対応品,RoHS対応品)

4. PERFORMANCE/性能

	Parameter 項目	Min	Typ	Max	Unit 単位	Notes 備考
Absolute Maximum Ratings 絶対最大定格	Supply voltage 電源	0.00	5.00	6.00	V	
	Storage temperature 保存温度	-40		85	deg C	
	Operatable acceleration 使用限界加速度			981.0	m/sec ²	
Operating conditions 動作環境	Supply voltage 電源電圧	4.75	5.00	5.25	V	
	Power supply noise 電源ノイズ			15.00	mVrms	0.5 to 100Hz
	Temperature 温度	-40	23	85	deg C	
	Humidity 湿度	5		95	%RH	Non-condensing 結露無

The following specifications apply for Vdd=5.00V and Temp=23deg C unless otherwise specified.
特に指定無き場合下記はVdd=5.00V、温度23°Cを条件とする。

Parameter 項目	Limit 限度	Unit 単位	Notes 備考
Rate range 測定範囲	+/- 100	deg/sec	Reference 参考値
Rate range 測定範囲	+/- 1.745	rad/sec	
Scale Factor 感度	20	mV/(deg/sec) typ.	Reference 参考値
Scale Factor 感度	22.92	% of Vdd/(rad/sec) typ.	
Initial Scale Factor accuracy 感度初期設定確度	+/- 1	% typ.	
Initial Scale Factor accuracy 感度初期設定確度	+/- 3	%	
Scale Factor variation with temp 感度温度変動	+/- 3	% typ.	Op temp. range 動作温度範囲
Scale Factor variation with temp 感度温度変動	+/- 5	%	Op temp. range 動作温度範囲
Scale Factor ratiometric error 感度電源電圧変動誤差	+/- 1	%	Op voltage range 動作電圧範囲
Bias ゼロ点	50	% typ. of Vdd	
Bias initial error ゼロ点初期設定誤差	+/- 60	mV	
Bias variation with temp ゼロ点温度変動	+/- 60	mV	Op temp. range 動作温度範囲
Bias ratiometric error ゼロ点電源電圧変動誤差	+/- 20	mV	Op voltage range 動作電圧範囲
Non linearity 非直線性	< 0.5	% of FS typ.	
Non linearity 非直線性	< 3	% of FS	
Quiescent noise 静止ノイズ	< 1	mVrms typ. (3~10Hz)	
Bandwidth 帯域	> 10	Hz	Gain(-3dB)
Cross axis sensitivity 他軸感度	< 5	%	
Power up time 起動時間	< 0.5	sec	From Vdd = 4.50V
Current dissipation 電流消費	< 50	mA	170mA when initializing(起動時)
Output Impedance 出力インピーダンス	100	Ω typ.	
Available output current 保証最小出力電流	> 0.5	mA	

5. TYPICAL RATE OUTPUT 出力電圧

$$Vo = \frac{1}{2} \times Vdd + \left(Ra \times SF \times \frac{Vdd}{5} \right) ; \text{ (Unit: Volt typ. 単位V typ.)}$$

where: Vo: Rateout (V), Vdd: Supply voltage (V), Ra: Applied rate (deg/s), SF: Scale Factor (V/ (deg/s))
ここで:Vo:ジャイロ出力(V), Vdd:電源電圧(V), Ra:角速度(deg/s), SF:感度(V/(deg/s))

6. RATIOMETRIC ERROR レシオメトリック・エラー (電源電圧による変動の誤差)

6.1 Bias ratiometric error ゼロ点電源電圧変動誤差

Bias ratiometric error are calculated as follows; ゼロ点電源電圧変動誤差は次の式で表される

$$Errb = Vb - \left(Vb_5 \times \frac{Vdd}{5} \right) \text{ (V)}$$

where Errb: Bias ratiometric error (V), Vb: Bias at Vdd (V), Vb₅: Bias at 5.00V (V), Vdd: Supply voltage (V)
ここで Errb:ゼロ点レシオメトリックエラー(V), Vb:Vddでのゼロ点(V), Vb₅:5.00V時のゼロ点 (V), Vdd:電源電圧(V)

6.2 Scale Factor ratiometric error 感度電源電圧変動誤差

Scale Factor ratiometric error are calculated as follows; 感度電源電圧変動誤差は次の式で表される

$$Errs = \left[SF - \left(SF_5 \times \left(\frac{Vdd}{5} \right) \right) \right] \times \frac{100}{SF} \text{ (%)}$$

where

Errs: Scale Factor ratiometric error (%), SF: Scale Factor at Vdd (V/ (deg/s))
SF₅: Scale Factor at 5.00V (V/ (deg/s)), Vdd: Supply voltage (V)

ここで

Errs: 感度レシオトリックエラー(%), SF:Vdd時の感度 (V/ (deg/s)) SF₅: 5.00V時の感度(V/ (deg/s)), Vdd:電源電圧(V)

7. SOLDERING / 半田付け

The product may not be subjected to beyond the maximum storage temperature (e.g. solder reflow chamber) at any time. Hand soldering is recommended.

本製品は何時も最高保存温度以上の環境（たとえば半田リフロー内）に置かれてはならない。従い手半田が推奨される。



Fig.3 CRS03-01R

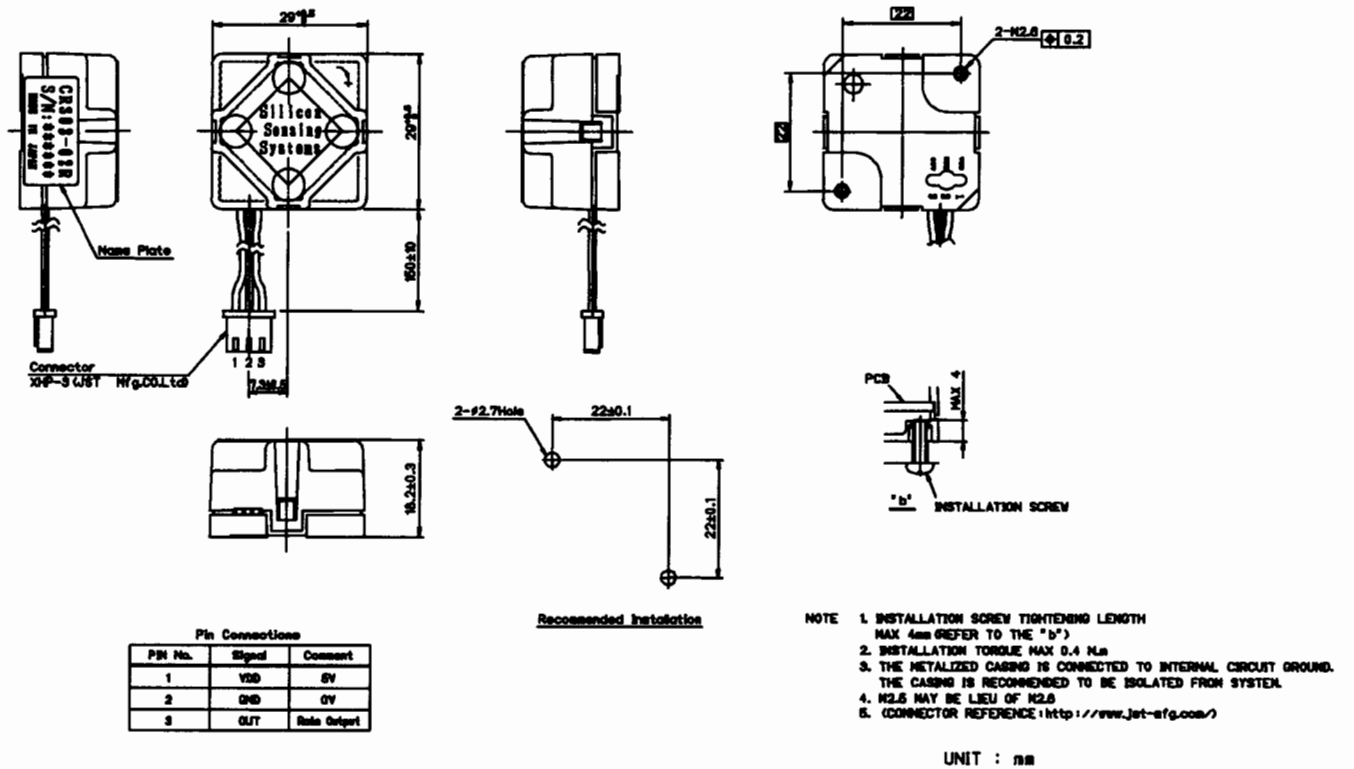

Fig.4 CRS03-02R

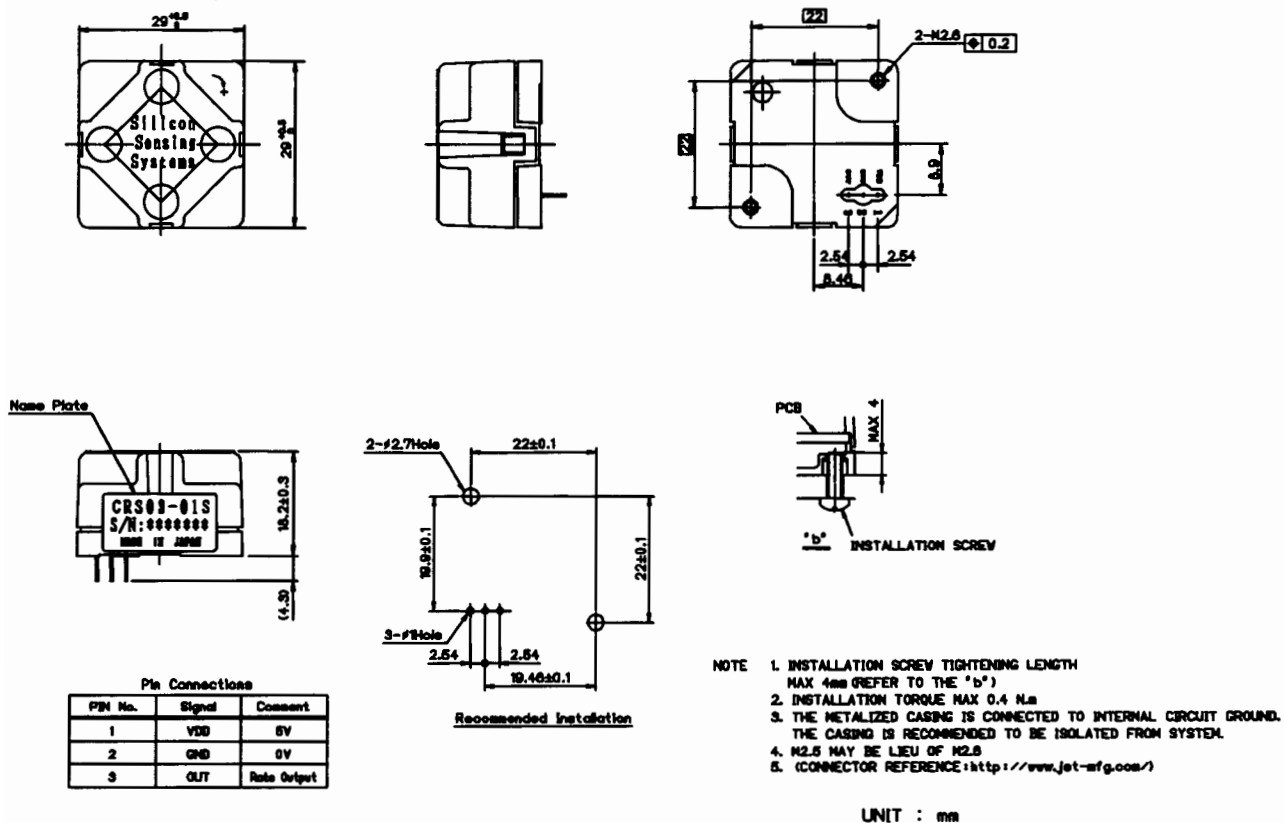

Fig.5 CRS03-01S

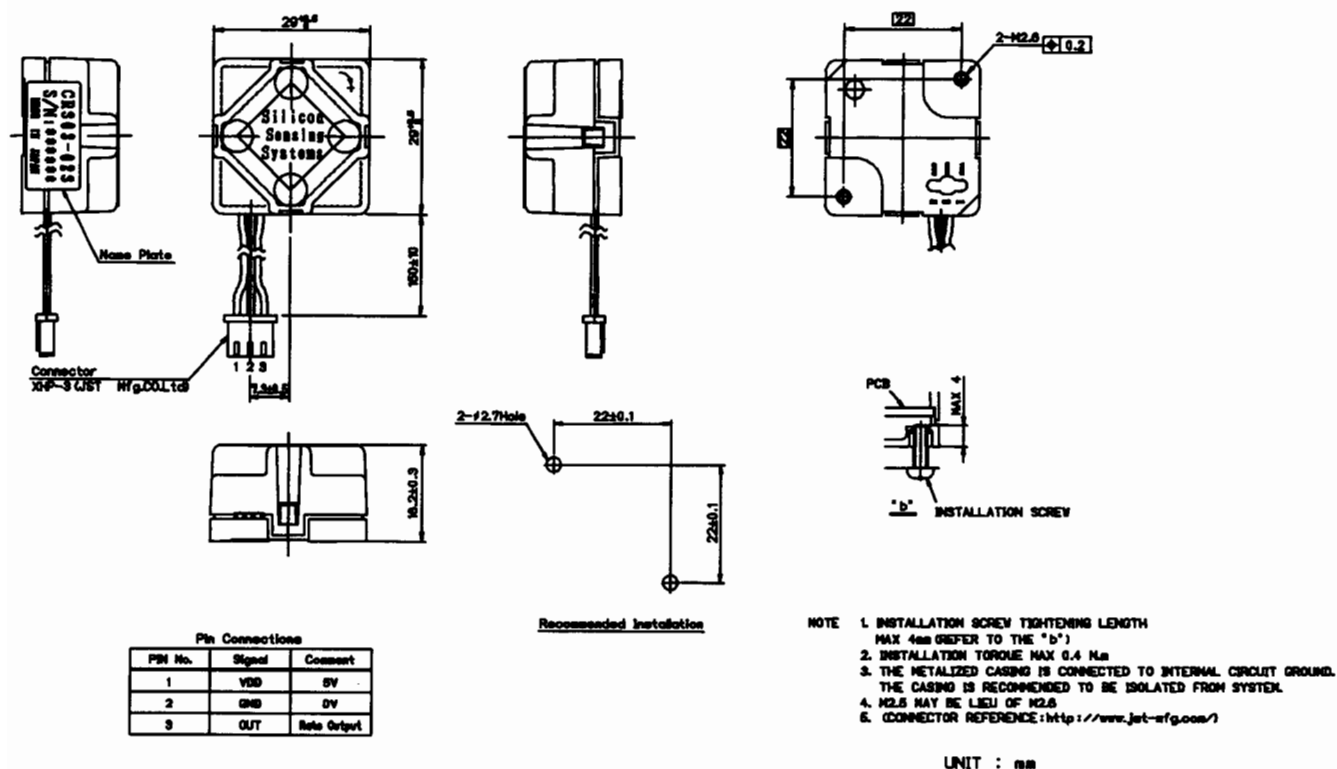

Fig.6 CRS03-02S



**Silicon Sensing UK copy of
SPP (Japan) originated**

Product Specification

for

CRS03-04-PS

Rev 6

(Commercial Rate Sensor)

&

CRS03-04R-PS

CRS03-04S-PS



2006.8.3

SSS UK

TITLE	DOC. NUMBER	REV.
PRODUCT SPECIFICATION FOR SINGLE AXIS SILICON VIBRATING STRUCTURE GYRO CRS03-04/CRS03-04R /CRS03-04S	SST - 0016	6

NOTICE:

User and/or Purchaser [Customer] shall indemnify and hold Silicon Sensing Systems Japan Limited ("SSSJL"), Silicon Sensing Systems Limited and its affiliates, including its members, shareholders, managers, directors, officers, employees, agents and representatives, harmless from and against any and all liabilities, claims, demands, actions, costs or expenses (including all reasonable legal or litigation costs), by whomever asserted and regardless of nature or kind, including without limitation and/or product liability claims arising from the use of any Gyro product supplied by SSSJL to [Customer], claims for personal injuries (including death) and damage to property, whether in tort or under contract, directly or indirectly, in whole or in part, attributed to or arising from the use by [Customer] of any Gyro product supplied by SSSJL to [Customer] for any purpose including but without limitation, installing the Gyro product on a product, equipment, or vehicle of any kind, or using the Gyro product for training or simulation purposes in relation to a product, equipment, or vehicle of any kind, or using the Gyro product for the support or maintenance of a product, equipment, or vehicle of any kind. SSSJL shall promptly notify [Customer] of any such claim for which indemnification will be sought. [Customer] shall have the right at its expense to assume and control the defence of such claims and SSSJL shall provide reasonable co-operation and information to [Customer] in order for [Customer] to defend the claims. [Customer] may not settle any such claim without the prior written consent of SSSJL, which consent may not be unreasonably withheld. Gyro product supplied by SSSJL is not warranted in any way for any period regardless of the existing laws and/or regulations unless agreed by and between SSSJL and [Customer] prior to purchasing. Applications that require extra reliability and quality possibly affecting the safety of living things (e.g. transport, combustion, security, etc.) or any applications which are thought to be beyond the focus of the product, should be consulted with SSS first. © Reproduction in any form prohibited. 禁無断転載 本書類の日本語部は参考用であり英語部を正とする。

6		P2 : Add an alternate ASIC model(CRS03-04S). P2 : Mechanical Description revised P6 : Fig.3 added	'06.08.01	小山山川 巻口科淵		
5		P2 : Model Number revised (RoHS compliance) P2 : Mechanical Description revised P4 : Fig.1 amended P5 : Fig.2 added	'05.11.14	小山山 巻南科口		
4		P1 : Notice revised P2 : 4.Performance Current dissipation revised P4 : Fig.1 amended	'04.04.20	小山山 巻南科 中村卓 山口		
3		P4 : Fig.1 amended	'02.10.17	徳北坂 江村本 中村卓		
B	SCN-0200	SCN-0200 P1,P2	'01.10.01	RT TK KS KY MT		
A	SCN-0150	SCN-0150 All pages	'01.02.05	RT TK KS KY MT		
REV.	MODIFY No.	REVISED PAGES	DATE	CHECKED		
		Silicon Sensing Systems Japan Ltd. 1-10 Fuso-cho, Amagasaki, Hyogo 660-0891 Japan Tel +81-6-6489-5868 Fax +81-6-6489-5910 E-Mail : sssj@spp.co.jp	DATE	APPROVED	CHECKED	PREPARED
			2000.12.28	tokue	kitamura	Yoshioka Sakamoto

1. DESCRIPTION/概要

The silicon vibrating structure gyroscope (Si-VSG) is a solid state single axis rate sensor. It is a stand alone unit and dc output is proportional to the rate of rotation and supply voltage.

The new concept ring-shaped micro-machined resonator shows distinguished resistance against external shocks and vibrations over a wide range of temperature.

本シリコン振動ジャイロは1軸ソリッドステート角速度センサであり角速度と供給電圧に比例した直流電圧を出力する。マイクロマシニングのリング型振動子により広い温度範囲で外部衝撃や振動に対し優れた耐性を発揮するものである。

2. MODEL NUMBER/製品型名

CRS03 – 04 Connector output range 200deg/sec コネクタ出力タイプ
 CRS03 – 04R Connector output range 200deg/sec コネクタ出力タイプ (RoHS Compliance / RoHS対応品)
 CRS03 – 04S Connector output range 200deg/sec コネクタ出力タイプ (GOA ASIC対応品)

CRS03 Basic Model Number 基本製品番号
 -xx Design Number タイプ識別番号
 -xxR Design Number タイプ識別番号 (RoHS Compliance / RoHS対応品)
 -xxS Design Number タイプ識別番号 (GOA ASIC対応品)

3. MECHANICAL DESCRIPTION/外形

The nominal dimensions are shown in Fig.1,2 ,3.(Fig2 RoHS compliance, Fig3 GOA ASIC model)

図 1 参照。(図 2 RoHS対応品、図 3 GOA ASIC対応品)

4. PERFORMANCE/性能

	Parameter 項目	Min	Typ	Max	Unit 単位	Notes 備考
Absolute Maximum Ratings 絶対最大定格	Supply voltage 電源	0.00	5.00	6.00	V	
	Storage temperature 保存温度	- 40		85	deg C	
	Operatable acceleration 使用限界加速度			981.0	m/sec ²	
Operating conditions 動作環境	Supply voltage 電源電圧	4.75	5.00	5.25	V	
	Power supply noise 電源ノイズ			15.00	mVrms	0.5 to 100Hz
	Temperature 温度	- 40	23	85	deg C	
	Humidity 湿度	5		95	%RH	Non-condensing 結露無

The following specifications apply for Vdd=5.00V and Temp=23deg C unless otherwise specified.
特に指定無き場合下記はVdd=5.00V、温度23℃を条件とする。

Parameter 項目	Limit 限度	Unit 単位	Notes 備考
Rate range 測定範囲	+/- 200	deg/sec	Reference 参考値
Rate range 測定範囲	+/- 3.491	rad/sec	
Scale Factor 感度	10	mV/(deg/sec) typ.	Reference 参考値
Scale Factor 感度	11.46	% of Vdd/(rad/sec) typ.	
Initial Scale Factor accuracy 感度初期設定確度	+/- 1	% typ.	
Initial Scale Factor accuracy 感度初期設定確度	+/- 3	%	
Scale Factor variation with temp.感度温度変動	+/- 3	% typ.	Op temp. range 動作温度範囲
Scale Factor variation with temp.感度温度変動	+/- 5	%	Op temp. range 動作温度範囲
Scale Factor ratiometric error 感度電源電圧変動誤差	+/- 1	%	Op voltage range動作電圧範囲
Bias ゼロ点	50	% typ. of Vdd	
Bias initial error ゼロ点初期設定誤差	+/- 60	mV	
Bias variation with temp.ゼロ点温度変動	+/- 60	mV	Op temp. range 動作温度範囲
Bias ratiometric error ゼロ点電源電圧変動誤差	+/- 20	mV	Op voltage range動作電圧範囲
Non linearity 非直線性	< 0.5	% of FS typ.	
Non linearity 非直線性	< 3	% of FS	
Quiescent noise 静止ノイズ	< 1	mVrms typ. (3~10Hz)	
Bandwidth 帯域	> 10	Hz	Gain (-3dB)
Cross axis sensitivity 他軸感度	< 5	%	
Power up time 起動時間	< 0.5	sec	From Vdd = 4.50V
Current dissipation 電流消費	< 50	mA	170mA when initializing(起動時)
Output Impedance 出力インピーダンス	100	Ω typ.	
Available output current 保証最小出力電流	> 0.5	mA	

5. TYPICAL RATE OUTPUT 出力電圧

$$V_o = \frac{1}{2} \times V_{dd} + \left(R_a \times S_F \times \frac{V_{dd}}{5} \right) ; \text{ (Unit: Volt typ. 単位V typ.)}$$

where: V_o: Rateout (V), V_{dd}: Supply voltage (V), R_a: Applied rate (deg/s), S_F: Scale Factor (V/ (deg/s))
ここで: V_o:シャイロ出力(V), V_{dd}:電源電圧(V), R_a:角速度(deg/s), S_F:感度(V/(deg/s))

6. RATIOMETRIC ERROR レシオメトリック・エラー (電源電圧による変動の誤差)

6.1 Bias ratiometric error ゼロ点電源電圧変動誤差

Bias ratiometric error are calculated as follows; ゼロ点電源電圧変動誤差は次の式で表される

$$Err_b = V_b - \left(V_{b_5} \times \frac{V_{dd}}{5} \right) \text{ (V)}$$

where Err_b: Bias ratiometric error (V), V_b: Bias at V_{dd} (V), V_{b₅}: Bias at 5.00V (V), V_{dd}: Supply voltage (V)
ここで Err_b:ゼロ点レシオメトリックエラー(V), V_b:V_{dd}でのゼロ点(V), V_{b₅}:5.00V時のゼロ点 (V), V_{dd}:電源電圧(V)

6.2 Scale Factor ratiometric error 感度電源電圧変動誤差

Scale Factor ratiometric error are calculated as follows; 感度電源電圧変動誤差は次の式で表される

$$Err_s = \left[SF - \left(SF_5 \times \left(\frac{V_{dd}}{5} \right) \right) \right] \times \frac{100}{SF} \text{ (%)}$$

where

Err_s: Scale Factor ratiometric error (%), S_F: Scale Factor at V_{dd} (V/ (deg/s))

S_{F₅}: Scale Factor at 5.00V (V/ (deg/s)), V_{dd}: Supply voltage (V)

ここで

Err_s: 感度レシオメトリックエラー(%), S_F:V_{dd}時の感度 (V/ (deg/s)) S_{F₅}: 5.00V時の感度(V/ (deg/s)), V_{dd}:電源電圧(V)

7. SOLDERING / 半田付け

The product may not be subjected to beyond the maximum storage temperature (e.g. solder reflow chamber) at any time. Hand soldering is recommended.

本製品は何時も最高保存温度以上の環境（たとえば半田リフロー内）に置かれてはならない。
従い手半田が推奨される。

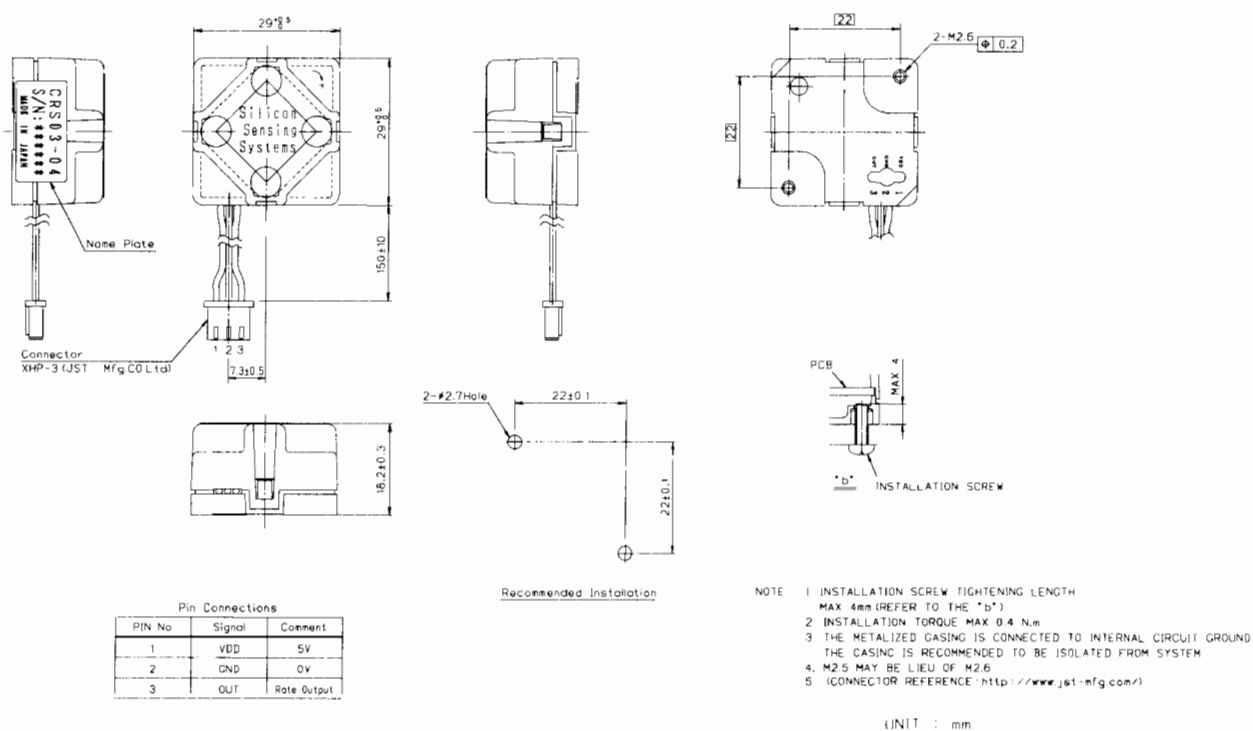

Fig.1 CRS03-04

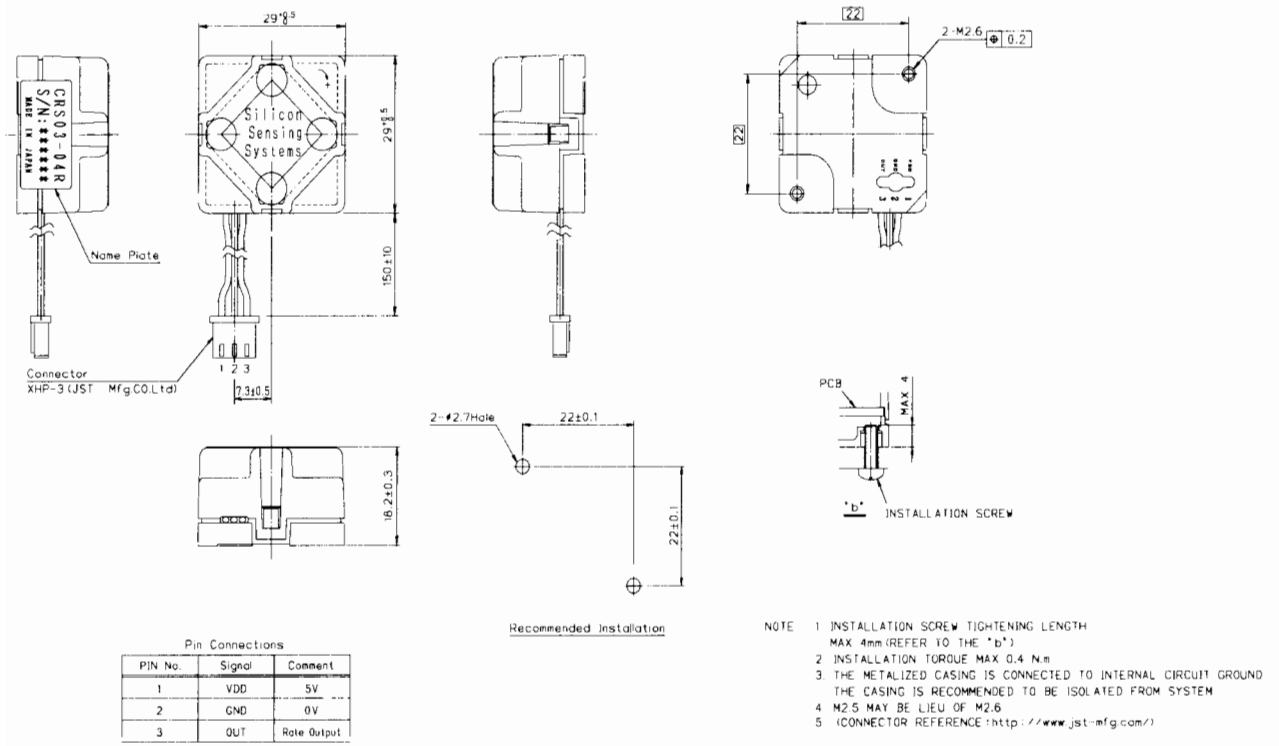

Fig.2 CRS03-04R

UNIT : mm

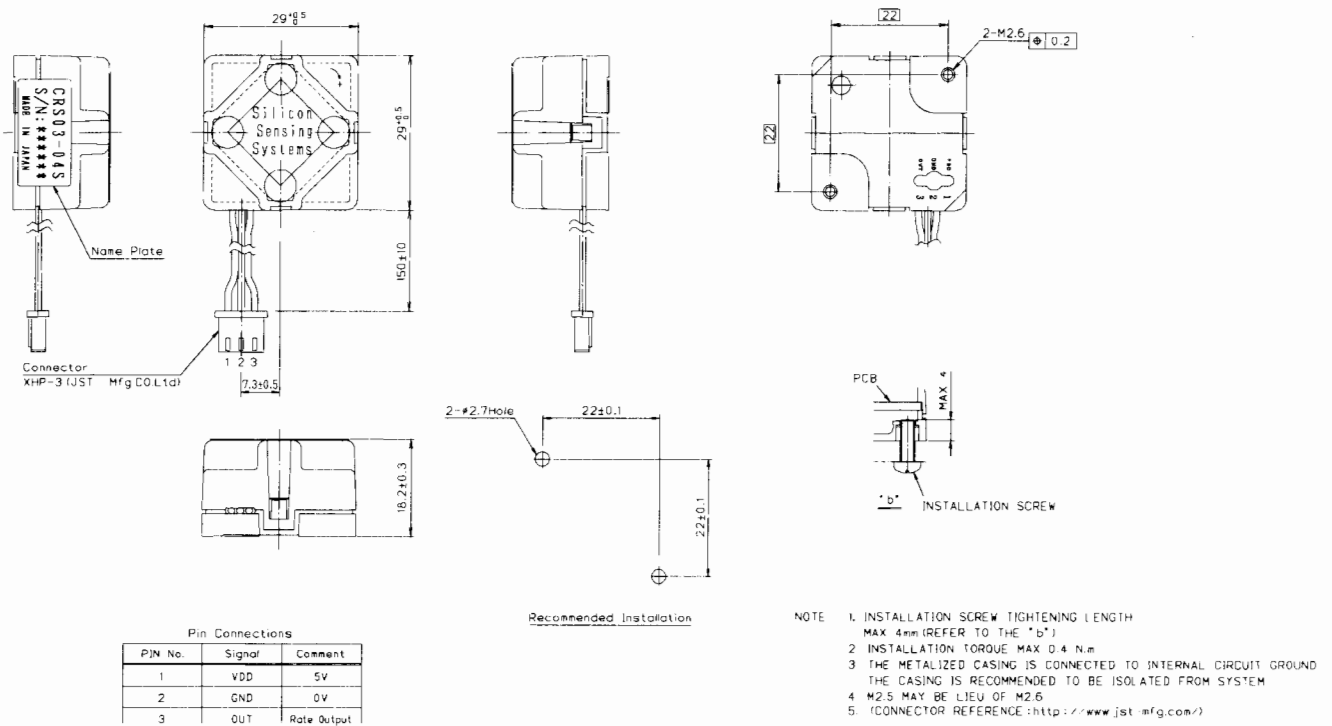

Fig.3 CRS03-04S