

ECL eCompass Series

Low Power Electronic Compass

General Description

The ECL eCompass series is a strap-down electronic compass designed specifically for commercial, industrial, and military users. The ECL will be of particular interest to ROV and AUV manufacturers who are concerned with power usage and accurate heading in all types of challenging conditions. In standby mode, it draws a mere 50 μ A and requires only 15 mA in run mode. It provides accurate heading data in less than a tenth of a second from wakeup. An extended range tilt sensor is available that allows for +/-60° of pitch and roll.

Other aspects of the ECL remain unchanged from the original ECS including its quick-connect, external serial interface. While the compass is in-place, and without disconnecting system wiring, a serial cable or available USB cable can be temporarily connected via the RJ12-style modular jack. This allows easy access during installation for calibration and tuning. It also provides a valuable diagnostic port and can be used for an auxiliary read-out when needed. In situations where a fixed installation is not desirable, the RJ12 connection can be used exclusively.

Among the host of user definable parameters is the selection of NMEA output data and update rate, operating mode as continuous or query-only, and angle data in degrees, mils, radians, or 16-bit integer (65536 counts per revolution). Compensation for both hard and soft iron influences is built-in.

Recommended applications are unmanned vehicles, robotics, weather buoys, antenna positioning, and marine navigation.

Jewell Instruments offers a development kit that includes the compass, serial cable, and software. The ECL is covered by a full one-year replacement warranty.

Features

- ◆ **High Accuracy**
 - ⇒ Heading within 0.5° or better
 - ⇒ Tilt within 0.2° or better
- ◆ **Wide Operating Range**
 - ⇒ ±60° Pitch and Roll*
 - ⇒ ±80° Dip angle range
 - ⇒ Temperature -20° to 70°C
 - ⇒ Local Hard Iron to ±1.5 Gauss
- ◆ **Fast Response**
 - ⇒ 14 readings per second
 - ⇒ Wake from standby in 75 msec
- ◆ **Single Supply Operation**
 - ⇒ 6 to 30V unregulated DC or
 - ⇒ 5V regulated DC
- ◆ **Low Power**
 - ⇒ 15 mA in run mode
 - ⇒ 5 mA in sample mode
 - ⇒ 50 μ A in standby mode
- ◆ **Wide Selection of Output data**
 - ⇒ Heading, pitch, and roll
 - ⇒ Magnetometer X, Y, and Z
 - ⇒ Dip angle
 - ⇒ Total, horizontal, and vertical magnetic field strength
 - ⇒ Horizontal X and Y magnetic field strength
- ◆ **Interface**
 - ⇒ Full-duplex RS-232 or TTL
- ◆ **In-System Configuration and Test**
 - ⇒ PC or laptop can be connected while unit operates in-situ
 - ⇒ Perform hard and soft iron calibration
 - ⇒ Monitor outputs and change user-definable settings

*with optional tilt sensor

Specifications

Heading Performance

Parameter	Value	Comments
Accuracy	$\pm 0.5^\circ$ rms	Typical, Tilt < 35°, Dip < 60°
Repeatability	$\pm 0.2^\circ$	No filter
Response time	75 msec	Minimum, no filter
Dip Angle Range	$\pm 80^\circ$	
Tilt Range	$\pm 42^\circ$	$\pm 60^\circ$ available
Update rate	14 per second	

Pitch and Roll Performance

Parameter	Value	Comments
Accuracy	$\pm 0.2^\circ$	Factory calibrated
Repeatability	$\pm 0.15^\circ$	No filter
Range	$\pm 42^\circ$	$\pm 60^\circ$ available
Settling time	0.5 sec	No damping

Electrical

Parameter	Value	Comments
Supply Current	<i>Below values are the same color</i>	
	15 mA operating	Typical
	5 mA sample	Typical
	50 μ A standby	Typical
Supply Voltage (V _{DD})	<i>Below values are the same color</i>	
	6 – 30 Vdc unregulated	
	5.0 Vdc regulated	4.9 Vdc min

Environmental

Parameter	Value	Comments
Operating Temp	-20° to 70 °C	
Storage Temperature	-40° to 125 °C	
Humidity	0 to 90%	Non-condensing

Mechanical

Enclosure Material	Plastic Enclosure (P Option): (ABS) Flame Retardant UL94 VO Aluminum Enclosure (A Option): Diecast Aluminum Alloy (Type 360.1)
PCB Size	1.6"W x 3.0"L x 0.6"/0.8"H, H required for tilt sensor
PCB Mounting	4 #4 screws, 1.4" x 2.2" spacing
Weight	Plastic Enclosure (P Option): 3.2 oz. (90.7 grams) Aluminum Enclosure (A Option): 7.2 oz. (204.1 grams)
Connectors	8 pin, single-row, 0.1" friction header 6 pin RJ12 modular jack

Interface

Signal type	RS232 or TTL
Baud rate	2400, 4800, 9600, or 19200 bps
Character Format	8 data, no parity, 1 stop
Input Buffer Size	90 characters
Output Buffer Size	110 characters
Output Format	NMEA 0183
Output Data Rate	1 to 1200 sentences per minute
Operating Modes	Continuous or sample
Angle Units	Degrees, mils, radians, 16-bit integer

*Specifications subject to change without notice on account of continued product development

How to Order

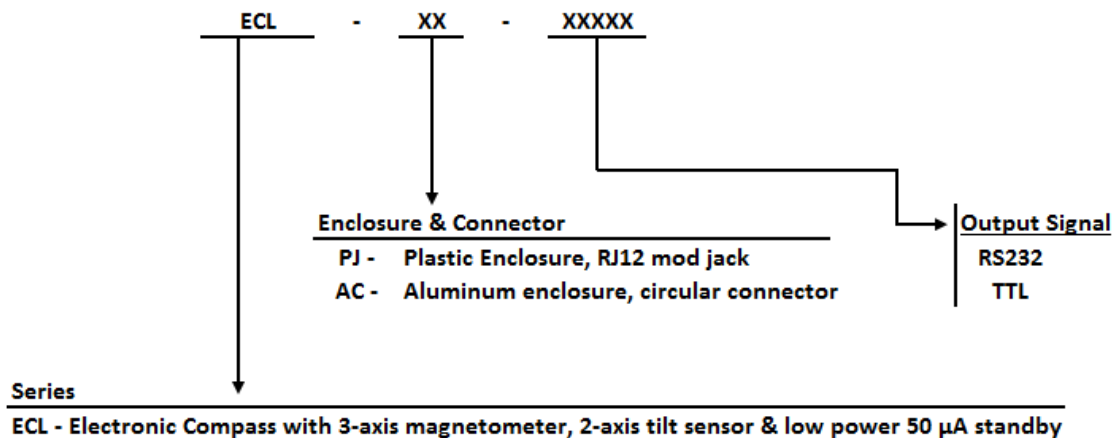

Example:

ECL-PJ-RS232

ECL Electronic Compass with 3-axis magnetometer & 2-axis tilt sensor, low power power 50 µA standby plastic enclosure, RJ12 mod jack & RS232 output signal

Dimensions of Aluminum Enclosure

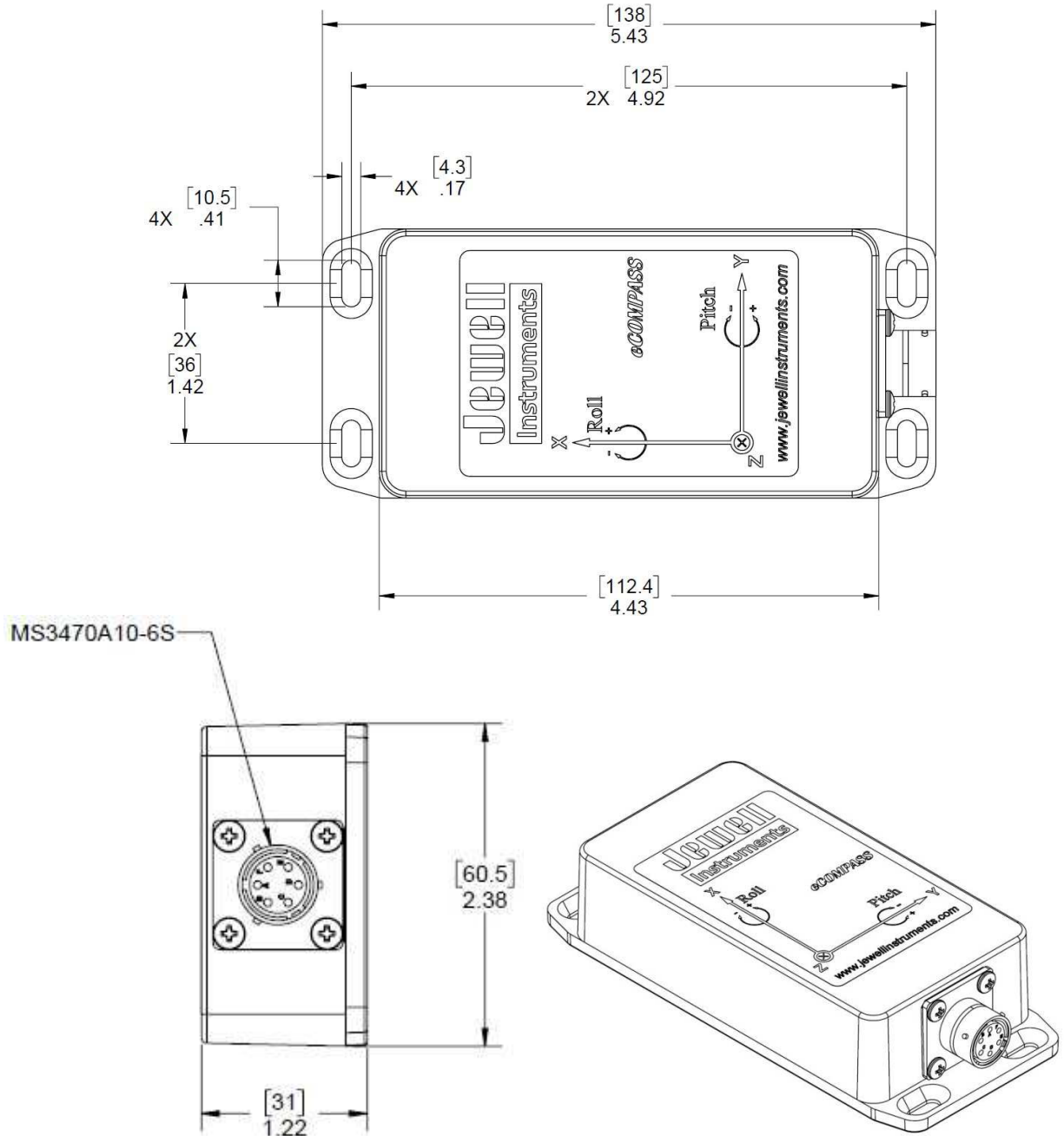

Dimensions: mm [in]

Dimensions of Plastic Enclosure

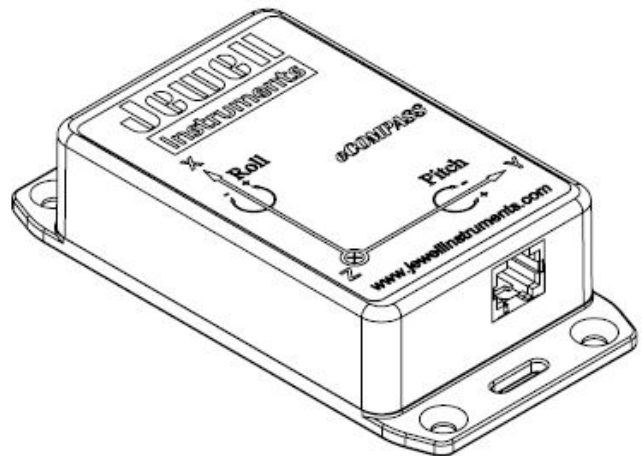
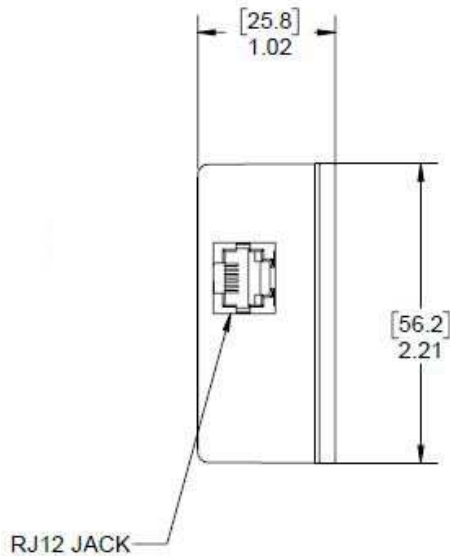
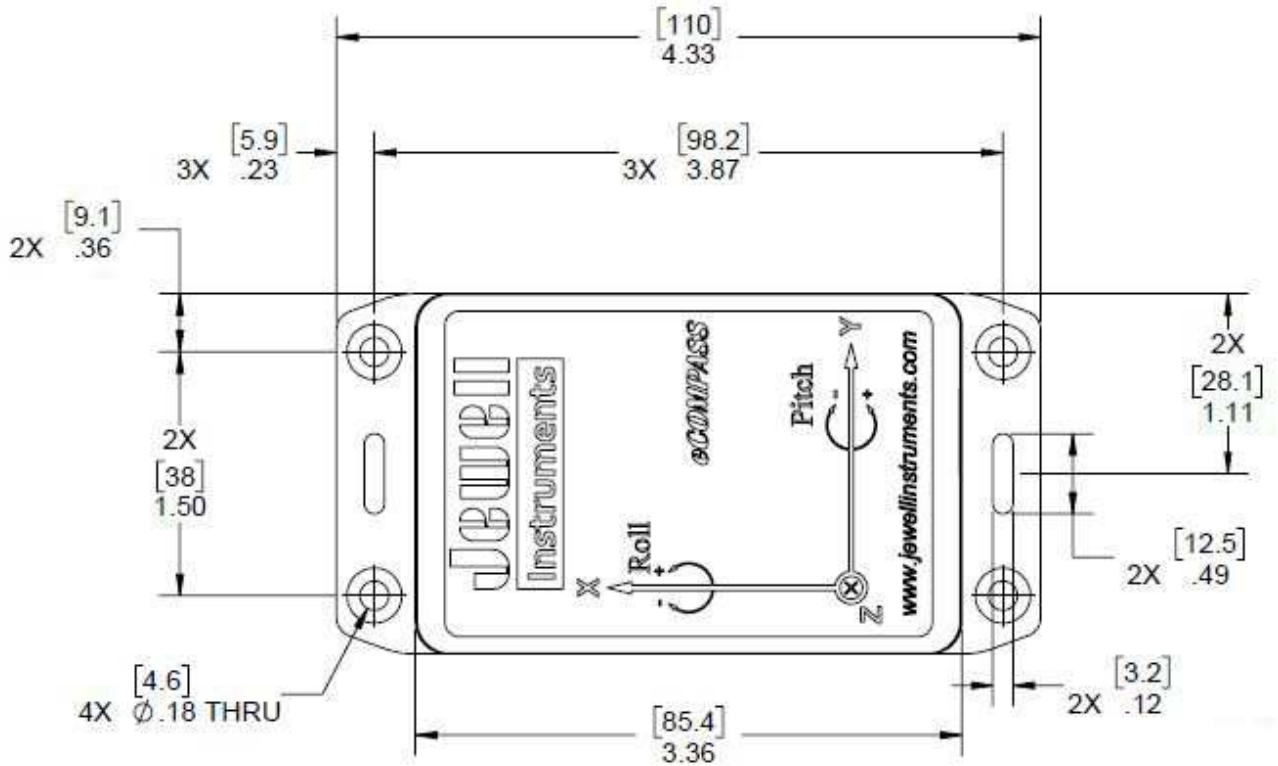

Dimensions: in [mm]

Pin Outs

J1 RJ-12 Jack Pin Out	
Pin 1	Ground
Pin 2	Power
Pin 3	TX
Pin 4	RX
Pin 5	Ground
Pin 6	100K

J2 8-Pin Header Pin Out	
Pin 1	Unregulated Power
Pin 2	RS232 TX Out
Pin 3	RS232 RX In
Pin 4	Regulated Power
Pin 5	TTL RX In
Pin 6	Ground
Pin 7	TTL TX Out
Pin 8	TTL Run/Sleep In

Interface Block Diagram

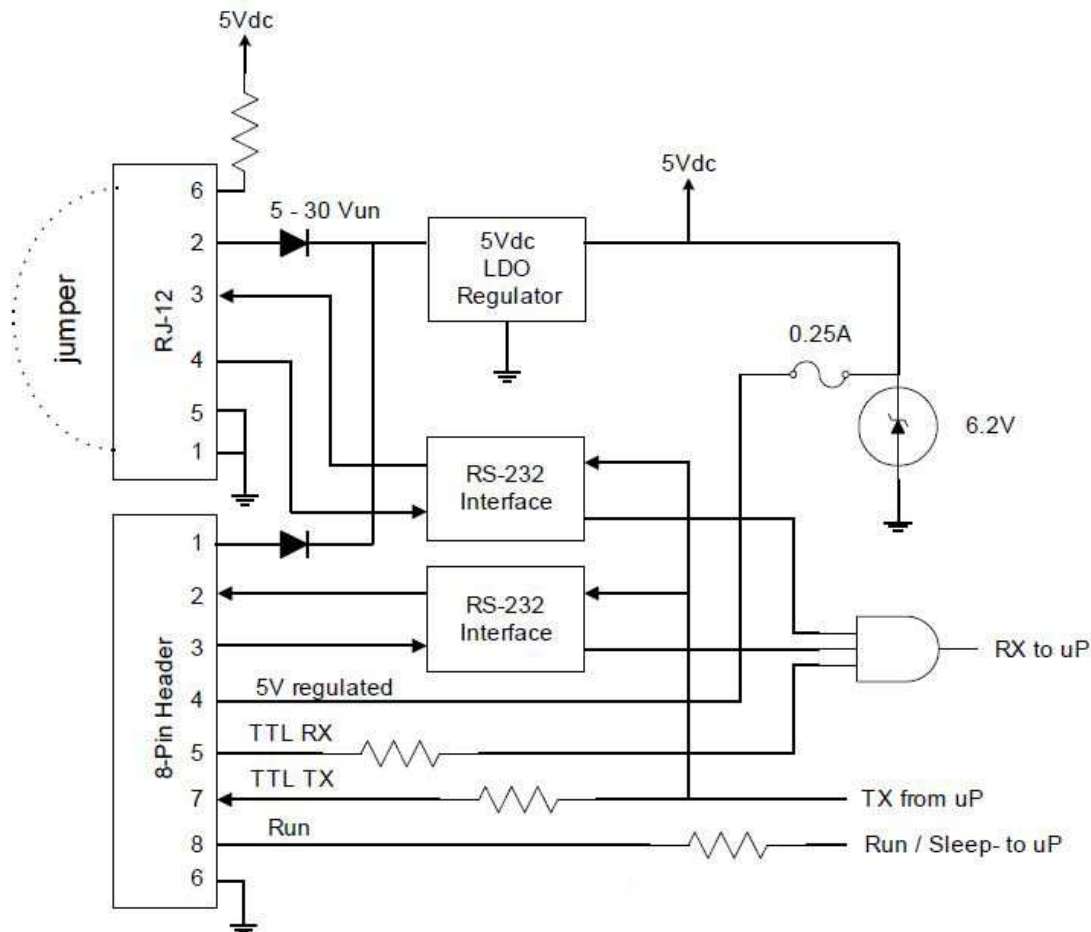

Wiring Drawings

RS-232

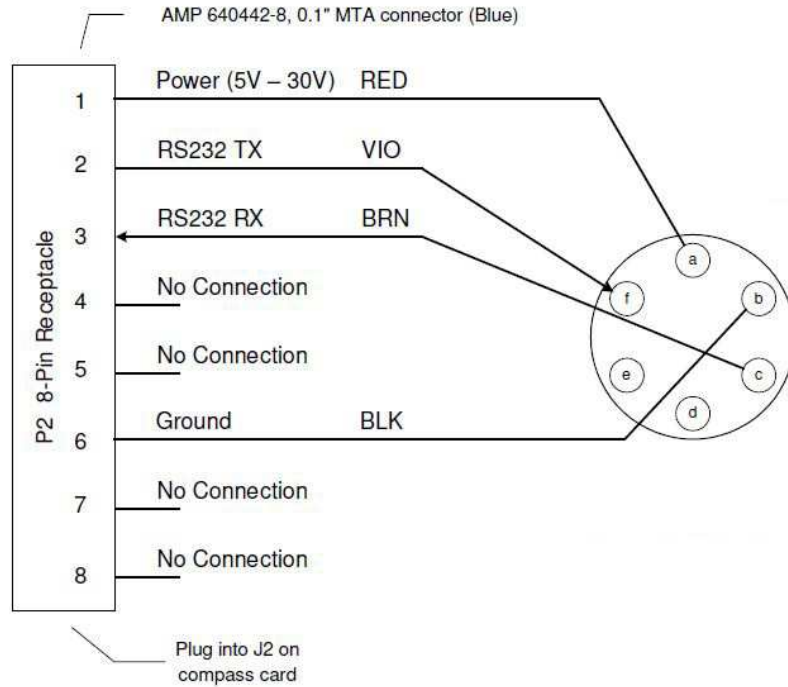

RS-485

