

EPXN



- Small size
- Silicon chip diaphragm for dry gas media
- Long term stability

DESCRIPTION

The EPXN is a high performance small pressure sensor using silicon chip for clean media (non corrosive). With its recessed port, it is best recommended for static applications or low frequency. Available with 10-32UN For M5 thread, EPXN is available with a cable or integral connector.

Offered in pressure ranges from 5 to 150 psi (0.3 to 10 bar), vented and absolute pressure. Various compensated temperature ranges are available from -40°C up to 90°C. The sensor is offered with an amplified or unamplified output.

FEATURES

- Available ranges 0-5 to 150 psi (0-0.3 to 10 bar)
- 0.3 % to 0.5 % accuracy
- Available with or without amplifier
- CE approved
- 0.2% zero & output stability over 6 months

APPLICATIONS

- Space flight and test
- Flight and marine testing
- Automotive and racing testing
- General test lab
- Space flight and test

STANDARD RANGES

Pressure ranges		Pressure Reference		Pressure Limit	Response Time ⁽¹⁾ (min.)	Output "FSO" ⁽²⁾ (nom.)	CNL&H (%FSO)	Thermal Zero Shift "TZS" (50°C)
(BAR)	(PSI)	Gage (type1)	abs. (type3)					
0.3	5	•	not available	3 x FS	20 ms	50 mV or 5V	±0.5%	±1 % FSO
1	15	•	•	3 x FS	20 ms	75 mV or 5V	±0.3%	±1 % FSO
2	30	•	•	3 x FS	20 ms	75 mV or 5V	±0.3%	±1 % FSO
5	75	•	•	3 x FS	20 ms	75 mV or 5V	±0.3%	±1 % FSO
10	150	•	•	3 x FS	20 ms	75 mV or 5V	±0.3%	±1 % FSO

Note 1 : useful frequency is a function of cavity resonance and thereby suitable for static and low frequency use only.

Note 2 : FSO is 50 mV and 75 mV nom. for types N0, N4, VO and V4; 5V nom. on all others.

EPXN

PERFORMANCE SPECIFICATIONS

PARAMETERS	VALUES	NOTES
Supply Voltage	N0, N4, V0 & V4 = 15VDC N2, N6, V2 & V6 = ±15VDC N3, N7, V3 & V7 = 28 VDC (24-32VDC)	See option table for other voltage
Input Resistance	N0, N4, V0 & V4 = 15KΩ nom. N2, N3, N6, N7, V2, V3, V6 & V7 = 3mA max.	
Output Resistance	N0, N4, V0 & V4 = 15KΩ nom. N2, N6, V2 & V6 = <1Ω N3, N7, V3 & V7 = 1KΩ	
Non-Repeatability	± 0.25% FSO	
Thermal Sensitivity Shift "TSS"	± 1%/50°C	
Operating Temperature	-40°C to 120°C	
Compensated temperature	0°C to 60°C	See option table for other temperature
Zero Offset at 23°C	± 5% FSO typ.	
CE conformance according to	EN 61010-1, EN 50081-1, EN 50082-1	
Zero Offset at 23°C	± 5% FSO typ.	

DIMENSIONS

EPXN-N0, -N2, -N3, -V0, -V2 & V3

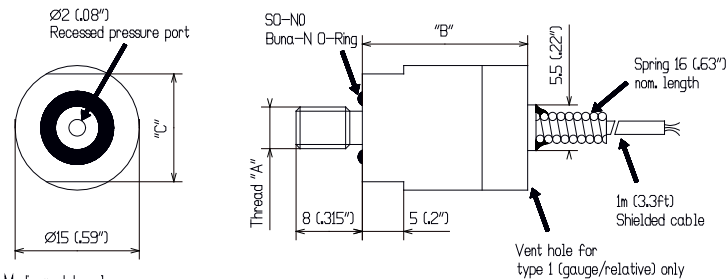

Model	Thread "A"	"B"	"C"
EPXN-N0	M5x0.8-6g	19 (.75")	13 (.512")
EPXN-N2, -N3	M5x0.8-6g	23 (.90")	13 (.512")
EPXN-V0	10-32 UNF-2A	19 (.75")	12.7 (.50")
EPXN-V2, -V3	10-32 UNF-2A	23 (.90")	12.7 (.50")

EPXN-N4, -N6, -N7, -V4, -V6 & V7

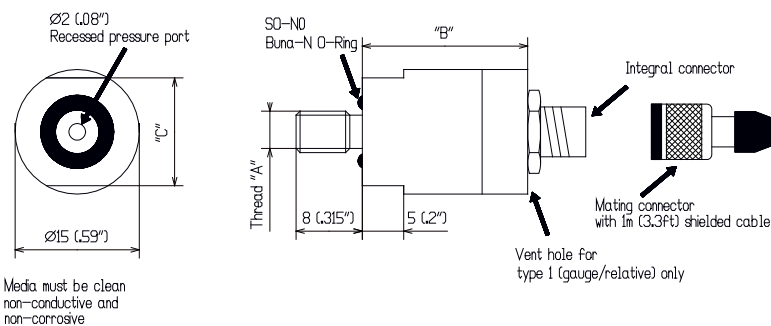

Model	Thread "A"	"B"	"C"
EPXN-N4	M5x0.8-6g	20 (.79")	13 (.512")
EPXN-N6, -N7	M5x0.8-6g	24 (.95")	13 (.512")
EPXN-V4	10-32 UNF-2A	20 (.79")	12.7 (.50")
EPXN-V6, -V7	10-32 UNF-2A	24 (.95")	12.7 (.50")

Dim : mm (inches)

EPXN

CONNECTIONS & INSTALLATION

EPXN-N0, -N4, -V0 & -V4

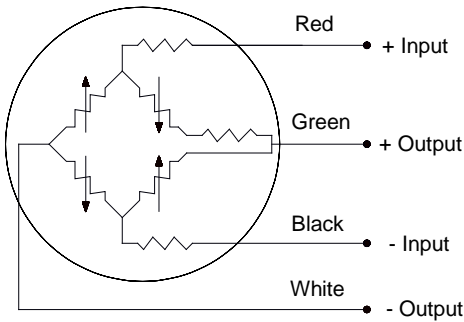

EPXN-N2, -N6, -V2 & -V6

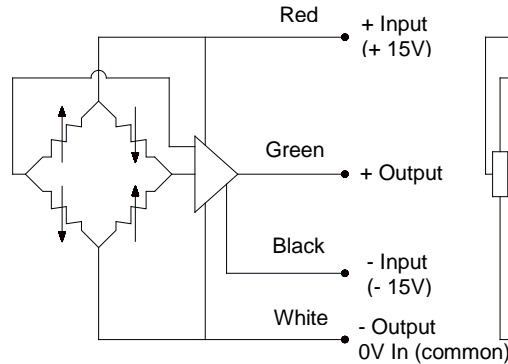

It is recommended that "0V COMMON" of the power supply be grounded if consistent with proper operation of the instrumentation system.

EPXN-N3, -N7, -V3 & -V7

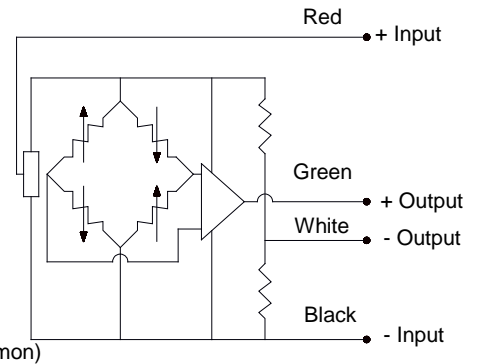

Common mode output voltage of + 2V nom. referred to - Input

Recommended installation torque : for all pressure range : 1 m.N (8 In.Lbs)

OPTIONS AND ACCESSORIES

OPTIONS	CODES	DESCRIPTIONS
Compensated Temperature Ranges	Z0	-40°C to 20°C
	Z1	-20°C to 40°C
	Z4	40°C to 90°C
	Z*	Non-standard, contact MEAS
Supply Voltage (12U: only for model N3, N7, V3, V7)	12U	8 to 16 VDC, FSO = 2.5 V with VCM = 1 V from -Output to Ground
	V*	Non-standard Excitation with FSO contact MEAS
Special Cable Length	L00F	Replace "00" with total length in feet
	L00M	Replace "00" with total length in meters
Connector Wired to Leads or Cable	C	Microtech type male or equivalent (w/o mate)
	RS	RJ Telephone type male (w/o mate)
Extra O-Rings for EPXN	SO-N0	Buna-N
	SO-N2	Viton
	SO-N3	Teflon

EPXN

ORDERING INFORMATION

Model	-	Body	Pres. Ref.	-	Range & Unit ⁽¹⁾		-	/Options
EPXN	-	N0 N6 V3 N2 N7 V4 N3 V0 V6 N4 V2 V7	1 = Gauge 3 = Absolute	-	0.3B 1B 2B 5B 10B	5P 15P 30P 75P 150P	-	/Z0, Z1, Z4 or Z* /12U or V* /L00F or L00M /C or RS

Note 1: select ranges in BAR with body N and ranges in PSI with body V.

Examples of model construction: EPXN-N21-10B-/Z1/L3M or EPXN-V33-75P-/Z0/L6F/C

The information in this sheet has been carefully reviewed and is believed to be accurate; however, no responsibility is assumed for inaccuracies. Furthermore, this information does not convey to the purchaser of such devices any license under the patent rights to the manufacturer. Measurement Specialties, Inc. reserves the right to make changes without further notice to any product herein. Measurement Specialties, Inc. makes no warranty, representation or guarantee regarding the suitability of its product for any particular purpose, nor does Measurement Specialties, Inc. assume any liability arising out of the application or use of any product or circuit and specifically disclaims any and all liability, including without limitation consequential or incidental damages. Typical parameters can and do vary in different applications. All operating parameters must be validated for each customer application by customer's technical experts. Measurement Specialties, Inc. does not convey any license under its patent rights nor the rights of others.