

eingefahren
min Ø298mm (approx.)

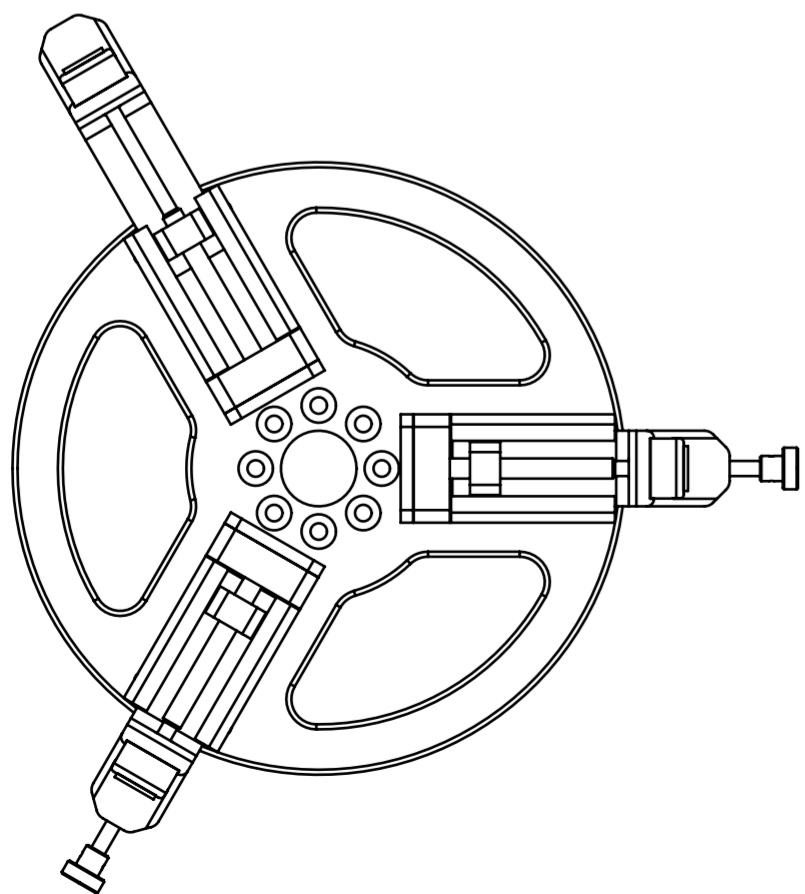

ausgefahren
max.Ø 365mm (approx.)

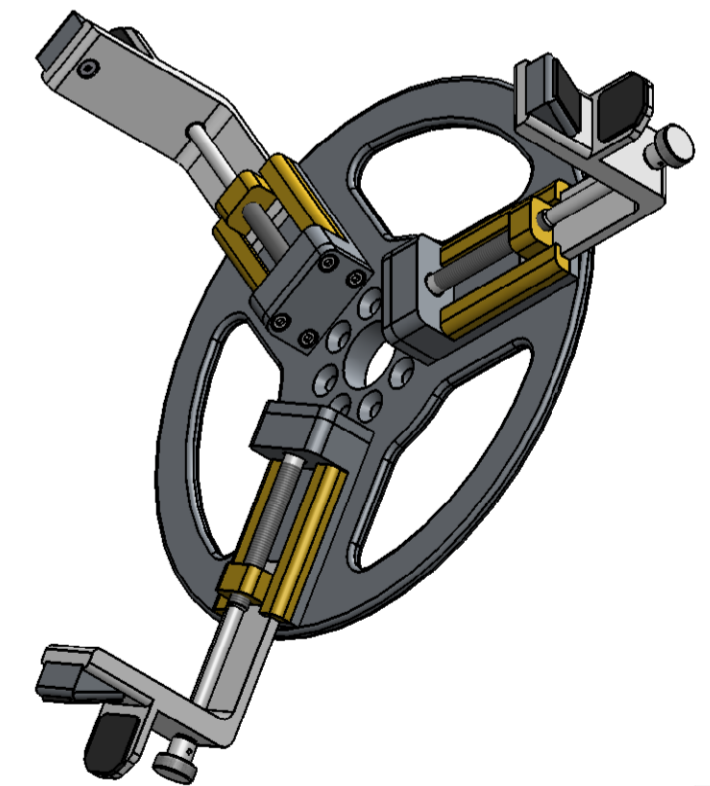
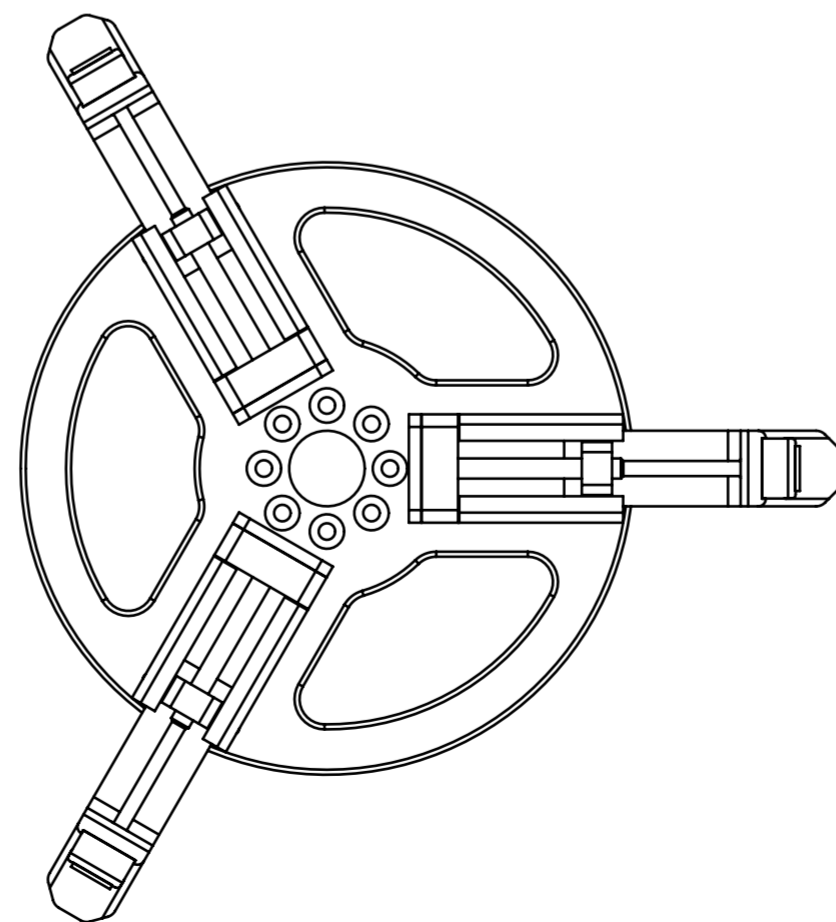

BA/FA-Nr.	
Art.-Nr.	
Art.-Nr.	
Art.-Nr.	
Art.-Nr.	5532210

Zulässige Abw.
ISO2768-mK

Tag	Name
Bearb. 04.11.2013	Hansel
Gepr.	

Werkstoff

überarbeitet	12.02.14	Hansel	
Zust.	Aenderung	Datum	Name

RMS Regelungs- und Messtechnik
Dynamic Test Systems
D-21465 Reinbek / Hamburg

Halterung Messlenkrad

FEL20/1-600.00

Ers.für Ers.durch 2 Blätter