

HXLR SERIES

LINEAR TO ROTARY CONVERSION MODULE



The UniMeasure HXLR module provides an easy method of converting linear motion to a digital output from nearly any industrial rotary encoder whether incremental or absolute. The module includes adapter plate, shaft coupling and o-ring seal to facilitate attachment of the encoder. With a NEMA 4 rated encoder attached to the environmentally sealed module, the completed assembly is also NEMA 4 capable.

Of note are the number of revolutions for the measurement range and the linear travel per revolution as shown in Table 15 on the following page. With this information, one can easily determine the resolution in counts per inch for a particular encoder. Prior to shipment, each Linear to Rotary Module is calibrated to determine the precise linear travel per revolution.

SPECIFICATIONS

GENERAL

Construction (Ranges to 80")	Anodized Aluminum Mounting Base, Stainless Steel and Anodized Aluminum Housing
Construction (Ranges 100" and more)	Stainless Steel Mounting Base, High Impact, Corrosion Resistant Thermoplastic Housings
Included Parts.....	Shaft Adapter, O-ring Seal, Encoder Specific Adapter Plate
Wire Rope (Ranges to 80").....	Ø.018 Nylon Jacketed Stainless Steel
Wire Rope (Ranges 100" and more).....	Ø.024 Stainless Steel
Available Ranges	See Table 15
Travel per Shaft Revolution	See Table 15
Wire Rope Tension.....	See Table 15
Wire Rope Diameter	See Table 15
Weight	See Table 15

ENVIRONMENTAL

Case Sealing	NEMA 4
Operating Temperature (Mechanism Only).....	-50°C to +95°C

MODEL NUMBER CONFIGURATION

HXLR- 0 - 1 2 3 - 4

BASIC CONFIGURATION (FOR ALL RANGES)

HXLR-100-S10-A

0 RANGE
Select Measurement Range From Supplemental Data, **Table 15**, Insert Corresponding Measurement Range Designator. 400" (10m) Maximum Range

1 WIRE ROPE

S Stainless Steel
(See Supplemental Data, Table 12)

N Ø.018 (0,45 mm)
Nylon Jacketed Stainless Steel
Ranges to 80" (2m) only, (formerly NJC)

J Ø.037 (0,94 mm)
Nylon Jacketed Stainless Steel
Ranges 100" (2.5m) to 500" (12.7m) only.

2 WIRE ROPE TENSION

1 Standard

2 Reduced (Ranges to 80" only)

3 WIRE ROPE EXIT DIRECTION

Use Number designators shown
RANGES TO 80" (2000 mm)

RANGES 100" TO 2000" (2,5 m TO 50 M)

4 ENCODER ADAPTER

A BEI H25D Flange Mount or Dynapar A25 Flange Mount

B BEI H25E Servo Mount

C CCC HMR90-64T

D Stegmann AG-626-XSR & Siemens 6FX-2001

E P&F TRD-G & RVI84 Servo Mount

F Balluff BDG-61 & Sick DRS60/DRS61 Internal Face Mount

G P&F TRD-J Servo Mount

H BEI MT-40D Flange Mount

J Beckhoff M3000 Servo Mount

K Stegmann AG-626-WSR Servo Mount

L US Digital A2-A-B-M (M Mount)

M Novotechnik IGP10 P6501 A502

N P&F AVS/AVM58 Style 011 Servo Mount

P BEI H38 Flange Mount

R Hohner 0310 Internal Face Mount

TABLE 15

Range Designator	Measurement Ranges		Shaft Revolutions for Range (Approx)	Nominal Travel per Shaft Revolution		Wire Rope Tension (Nominal)		Wire Rope Diameter		Weight		DIMENSIONAL INFORMATION
	(inch)	(mm)		(inch)	(mm)	(oz)	(N)	(inch)	(mm)	(lb)	(Kg)	
2	2	50	.94	2.11	53.7	34	9.4	.016	.41	2	0.9	See Figure 1
3	3	75	.97	3.09	78.4	24	6.7	.016	.41	2	0.9	
4	4	100	.97	4.11	104.4	24	6.7	.016	.41	2	0.9	
5	5	125	.98	5.11	129.9	19	5.3	.016	.41	2	0.9	
6	6	150	.99	6.07	154.2	24	6.7	.016	.41	2	0.9	
10	10	250	4.70	2.11	53.7	34	9.4	.016	.41	2	0.9	
15	15	390	4.85	3.09	78.4	24	6.7	.016	.41	2	0.9	
20	20	500	4.85	4.11	104.4	24	6.7	.016	.41	2	0.9	
25	25	640	4.90	5.11	129.9	19	5.3	.016	.41	2	0.9	
30	30	750	9.70	3.09	78.4	24	6.7	.016	.41	2	0.9	
40	40	1000	9.70	4.11	104.4	24	6.7	.016	.41	2	0.9	
50	50	1250	9.80	5.11	129.9	19	5.3	.016	.41	2	0.9	
60	60	1500	9.90	6.07	154.2	24	6.7	.016	.41	2	0.9	
80	80	2.0m	9.93	8.05	204.5	21	5.8	.016	.41	2	0.9	
100	100	2.5m	6.63	15.07	382.9	36	10.0	.024	0.6	6.8	3.1	See Figure 2
120	120	3.0m	7.96	15.07	382.9	36	10.0	.024	0.6	6.8	3.1	
150	150	3.8m	9.95	15.07	382.9	36	10.0	.024	0.6	6.8	3.1	
200	200	5.0m	13.27	15.07	382.9	36	10.0	.024	0.6	6.8	3.1	
250	250	6.3m	16.58	15.07	382.9	36	10.0	.024	0.6	6.8	3.1	
300	300	7.5m	19.90	15.07	382.9	36	10.0	.024	0.6	6.8	3.1	
350	350	8.8m	23.21	15.07	382.9	36	10.0	.024	0.6	6.8	3.1	
400	400	10.0m	26.53	15.07	382.9	36	10.0	.024	0.6	6.8	3.1	

DIMENSIONAL INFORMATION

RANGES TO 80" (2 m)

Fig. 1

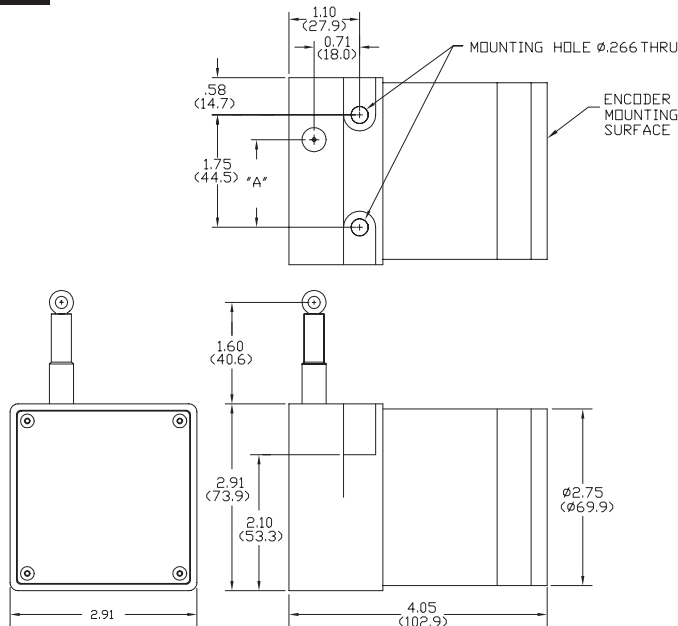

RANGE	"A"	
	inch	mm
2", 10"	1.21	30.8
3", 15", 30"	1.37	34.7
4", 20", 40"	1.53	38.8
5", 25", 50"	1.69	42.9
60"	1.84	46.8
80"	2.08	52.8

RANGES 100" (2 m) TO 400" (8 m)

Fig. 2

