

Deflection & Natural Frequency

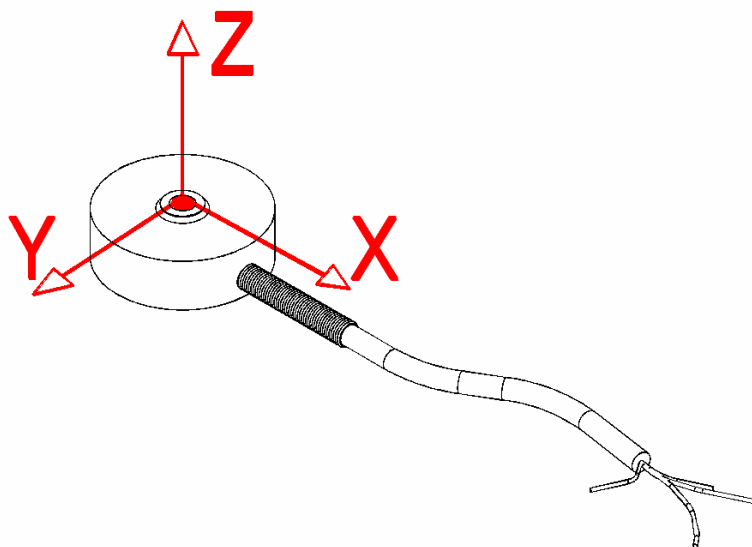

Material	Capacity (lb)	Deflection (in.)	Natural Frequency (Hz)	β
(S.S.*)	25	0.0009	13,800	0.0015
	50	0.0010	16,000	0.0019
	100	0.0010	19,600	0.0025
	150	0.0010	21,400	0.0031
	250	0.0010	24,400	0.0040
	300	0.0008	27,300	0.0050
	500	0.0010	31,600	0.0049
	1,000	0.0011	36,800	0.0068

*FN results are based on calculation of deflection & weight scene on Sensor arm.

Natural Frequency & Frequency Response Equation's:

$$\text{Natural Frequency (FN)} = 3.13 \sqrt{\frac{1}{\frac{\beta}{\text{Capacity}} \cdot \text{Deflection}}} \text{ (Hz)}$$

$$\text{Frequency Response with load (FR)} = 3.13 \sqrt{\frac{1}{\frac{\beta + \text{AppliedLoad}}{\text{Capacity}} \cdot \text{Deflection}}} \text{ (Hz)}$$

This documentation was generated and completed to ~~where β values are obtained by Futek Engineers~~ where β values are obtained by Futek Engineers. Analysis, Empirical data and Multiple Testing Simulations. The information and recommendations on this document are presented in good faith and believed to be correct however, FUTEK Advanced Sensor Technology makes no representations or warranties as to the completeness or accuracy of the information.

This documentation was generated and completed to the best ability of FUTEK's Engineering Team using FEA Analysis, Empirical data and Multiple Testing Simulations. The information and recommendations on this document are presented in good faith and believed to be correct however, FUTEK Advanced Sensor Technology makes no representations or warranties as to the completeness or accuracy of the information.