

## Model # LRF400 (L2338) Series

### Extraneous Load Factors

**Equation:**  $\sigma_{max} \geq (A)F_x + (B)F_y + (C)F_z + (D)M_x + (E)M_y + (F)M_z$

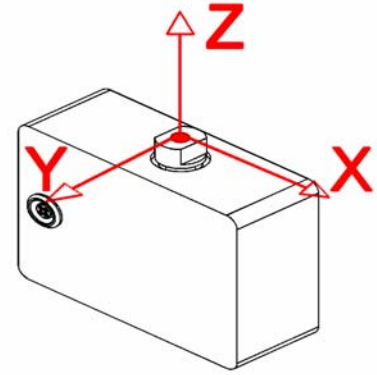

**Material:** 2024-T4 Aluminum (AL\*)

Material	Capacity (lb)	A	B	C	D	E	F
(AL*)	0.02205	4897.96	144807.26	68616.78	89705.22	3083.90	29705.22
	0.25	1440.00	16256.00	29232.00	10084.00	896.00	3656.00
	0.5	1326.00	12894.00	23616.00	8156.00	820.00	3150.00
	1.0	1044.00	10449.00	12703.00	6664.00	638.00	2464.00
	2.2	330.45	1335.45	6036.79	922.73	366.36	1340.00
	5	302.20	1041.20	1915.97	621.00	336.00	909.40
	10	313.40	712.70	1267.21	455.80	347.80	653.50
	25	305.40	472.84	540.41	324.28	339.36	418.92
	50	510.96	507.76	298.83	561.60	570.00	443.64
100	295.21	324.95	165.25	346.40	327.51	351.28	

#### $\sigma_{max}$ Table

Material	Static Load (=60% Y.S.)	Fatigue (Non Reversing Loads)	Fatigue (Full Reversing Loads)
2024-T4/T351	28,000	18,000	15,000

\*Value is 75% of Fatigue Strength based on 10-20 x 10<sup>6</sup> cycles and allow for factors that influence Fatigue such as surface finish, stress concentrations, corrosion, temperature and other variables for the production of the transducer, for infinite Fatigue Life (100 x 10<sup>6</sup>) use 75% of values shown.

### Deflection & Natural Frequency

Material	Capacity (lb)	Deflection (in.)	Natural Frequency (Hz)	$\beta$ (10 <sup>-4</sup> )
(AL*)	0.02205	0.0007	180	95
	0.25	0.0024	220	222
	0.5	0.0014	390	222
	1	0.0043	320	222
	2.2	0.0040	320	541
	5	0.0049	430	541
	10	0.0046	630	543
	25	0.0046	990	543
	50	0.0044	1430	548
100	0.0048	1930	548	

\*FN results are based on calculation of deflection & weight scene on Sensor arm.

This documentation was generated and completed to the best ability of FUTEK's Engineering Team using FEA Analysis, Empirical data and Multiple Testing Simulations. The information and recommendations on this document are presented in good faith and believed to be correct however, FUTEK Advanced Sensor Technology makes no representations or warranties as to the completeness or accuracy of the information.

### Natural Frequency & Frequency Response Equation's:

$$\text{Natural Frequency (FN)} = \pi \sqrt{1/((\beta / \text{Capacity}) * \text{Deflection})} \text{ (Hz)}$$

$$\text{Frequency Response with load (FR)} = \pi \sqrt{1/((\beta + \text{AppliedLoad} / \text{Capacity}) * \text{Deflection})} \text{ (Hz)}$$

\*Where  $\beta$  values are obtained by Futek Engineers