

Input Ranges From $\pm 3^\circ$ to $\pm 90^\circ$ Rugged, High Precision, Low Cost, Dual-Ended Power Input Inclinator



The Jewell **Emerald Series** inclinometer is a low cost, high precision inclinometer designed with higher accuracy sensor than comparable MEMS devices. Applications include robotics, construction equipment, industrial measurement and control, and precision machining.

Features

- Extremely Rugged
- Lower Cost than Traditional Forced-Balance Inclinometers
- High Accuracy
- Greater Precision than MEMS Technologies
- $\pm 5V$ DC Output
- Dual Power Input

Applications

- Aerospace
- Military
- Robotics
- Academic Research
- Geotechnical Monitoring
- Track Monitoring and Testing
- Vehicle Wheel Alignment

Outline Diagram

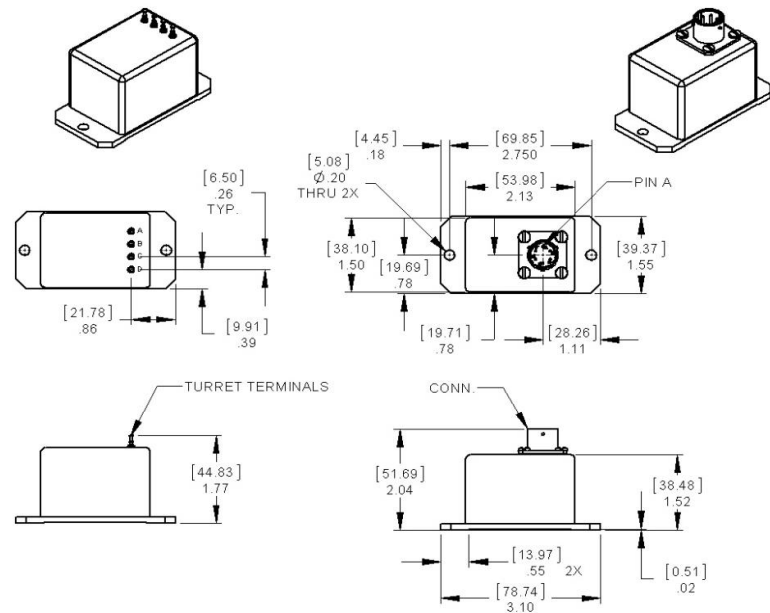

Dimensions in inches [mm]

Pin Out (Options: C-connector, P-Pin)

Pin Option		Connector Option	
A	Positive Input Power	A	Positive Input Power
B	Power/Signal Common	B	Power/Signal Common
C	Negative Input Power	C	Negative Input Power
D	Signal	D	Signal
		E	N/C
		F	N/C

Performance Specifications

STATIC/DYNAMIC

Input Range, °:	±3	±14.5	±30	±45	±60	±90
Full Range Output (FRO -Note 1) VDC ±0.5%:	±5	±5	±5	±5	±5	±5
Nonlinearity (Note 2) % FRO maximum:	0.05	0.02	0.02	0.02	0.04	0.05
Scale Factor, Volts/g, nominal:	95.5	20.0	10.0	7.1	5.8	5
Scale Factor Temp. Sensitivity (SFTS), PPM /°C maximum:	100	100	100	100	100	100
Bandwidth (-3 dB), Hz nominal:	5.0	5.0	5.0	5.0	5.0	5.0
Output Axis Misalignment, ° maximum:	0.25	0.50	0.50	0.50	0.50	0.50
Pendulous Axis Misalignment, ° maximum:	0.25	0.50	0.50	0.50	0.50	0.50
0° Output, Volts range:	±0.05	±0.05	±0.05	±0.05	±0.05	±0.05
0° Output Temp. Sensitivity, Volts /°C maximum:	0.0070	0.0017	0.0010	0.0008	0.0007	0.0007
Resolution and Threshold (Note 3), μradians maximum:	1	1	1	1	1	1

ELECTRICAL

Number of Axes:	1
Input Voltage Range, (VDC):	±12 to ±18
Input Current, mA, max:	40
Output Impedance, Ohms, nom:	10
Noise, Vrms, maximum:	0.002

ENCLOSURE

Seal:	IP65
-------	------

ENVIRONMENTAL

Operating Temp Range:	-55°C to +85°C
Storage Temp Range:	-60°C to +90°C
Shock:	500g, 1 msec, ½ sine

Notes: Note 1: Full Range is defined "from negative full input angle to positive full input angle."

Note 2: Nonlinearity is specified as deviation of output referenced to theoretical sine function value, independent of misalignment.

Note 3: Full Resolution is achieved with noise reduction techniques.

Custom Capabilities

- 15 to 30V single-ended input option available
- Pigtail and Connector alternative options available
- Custom ranges and bandwidths available

How to Order

Connector Version		Pin Version	
Model #	Part #	Model #	Part #
SMIC-D-3	02550308-001	SMIP-D-3	02550307-001
SMIC-D-14.5	02550308-002	SMIP-D-14.5	02550307-002
SMIC-D-30	02550308-003	SMIP-D-30	02550307-003
SMIC-D-45	02550308-004	SMIP-D-45	02550307-004
SMIC-D-60	02550308-005	SMIP-D-60	02550307-005
SMIC-D-90	02550308-006	SMIP-D-90	02550307-006