

TRACKER 211

Low Cost Panel Indicator



A Budget Priced Universal Input Panel Indicator
for Temperature and Process Measurement



Celebrating 20 years in the design and manufacture of innovative hardware and software products for the Telecommunication and Process Measurement Industries.

TRACKER 200 SERIES

Digital Panel Indicator Solutions for:

Displacement	- T280, T260, T220, T210 Series
Temperature	- T232, T220, T210 Series
Frequency	- T280 Series
Totalising	- T280 Series
Weighing	- T240, T220, T210 Series
Pressure	- T250, T232, T220, T210 Series
Encoder	- T280 Series
Timing	- T280 Series
Flow	- T280, T220, T210 Series

Ask your Tracker supplier for full details

© Data Track Process Instruments Ltd. 2000 - 2011

No part of this publication may be reproduced or transmitted in any form or by any means, electronic, mechanical, photocopying, recording or otherwise, or stored in any retrieval system of any kind, without the written permission of Data Track Process Instruments Ltd.

DATA TRACK PROCESS INSTRUMENTS

Contents

Introduction.....	2
Installation	3
Connections	5
Connecting the Sensor	6
Powering the Instrument	7
Operator Functions.....	8
The Setup Menus	9
Configuration Menu Map.....	12
Menu Options	14
Messages.....	18

Introduction

This Setup Guide describes how to install and configure your instrument.



This instrument is marked with the international hazard symbol. It is important to read this Setup Guide before installing or commissioning your panel meter as it contains important information relating to safety and Electromagnetic Compatibility EMC.

The instrument provides the following features as standard:

- Universal input for mV, mA, volt, thermocouple, RTD and resistance.
- 1 configurable alarm with relay output.
- 4 digit bright LED display.
- Transducer/transmitter supplies.
- <110mm behind panel depth (or 100mm without any options fitted).

The instrument provides the following features as options:

- Isolated 4 - 20mA scaleable retransmission output.
- Up to 2 additional alarms with relay outputs.
- Front panel keypad with function keys.

Installation

To install your instrument, you will need to carry out the following steps:

- Apply the engineering units label to the right-hand side of the display panel. A sheet of labels covering the most commonly used engineering units is supplied with all units. If the unit you require is not on the sheet, a blank label is provided on which you can use LETRASET™.
- Install the instrument into a panel.
- Make connections to the instrument.

PLEASE NOTE:

- Ensure that the power to the instrument is switched off before carrying out any installation or maintenance work.
- It is recommended that all connections to the terminals are made using ferrules to afford greater reliability and to prevent short circuits between adjacent terminals.
- Avoid installing the instrument close to switch gear, contactors or motor starters.
- Do not place signal and power supply wiring in the same loom.
- Use screened cables or wires for all signal/sensor leads with screen earthed at one point only.

Panel Mounting

The instrument is supplied with an installation kit consisting of a mounting clamp, a panel sealing gasket and terminal connectors.

Ensure that there is sufficient space behind the instrument panel - the instrument requires a depth of 100mm (110mm when any options are fitted) plus enough space to allow safe routing of cables.

To install the instrument:

1. Make panel cut-out with the dimensions as shown overleaf. Panel thickness from 1.5mm to 9.5mm can be accommodated.

Temperature & Process Measurement Indicators Setup Guide



2. Fit the rubber seal by slipping it over the unit from the rear of the box and pushing it forwards until it sits behind the front lip of the unit.
3. Insert the instrument into the panel from the front, pushing it through as far as the front lip, to ensure correct seating of the rubber seal between the panel and the unit.
4. Working from behind the panel, take the mounting clamp, slide over the rear of the instrument and push forwards.
5. Continue to push the clip forward until the ratchet operates and the clamp is sufficiently compressed to apply adequate pressure on the panel.

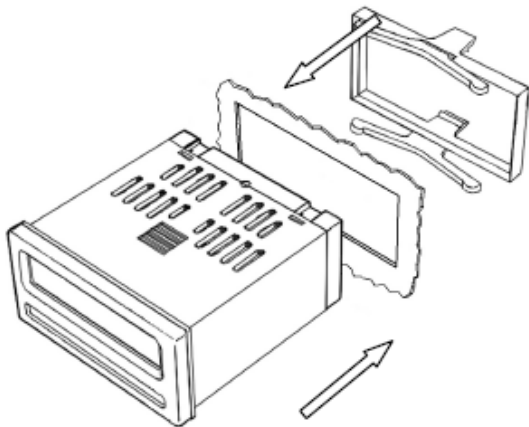

Connections

The diagram below shows the rear panel terminal connection arrangement.

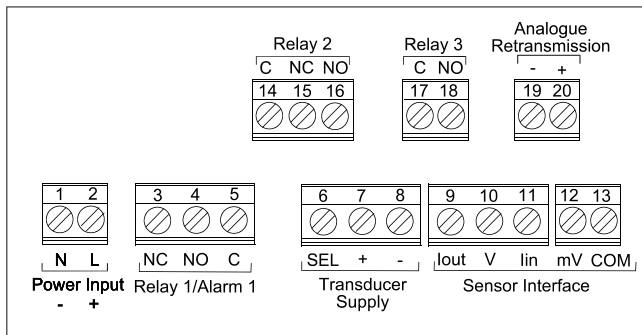

Rear Panel Terminal Connections



Ensure the power supply is connected to Terminals 1 & 2 (marked N & L).

Connecting the Sensor

Thermocouple/mV

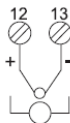

Resistance & RTD Measurements

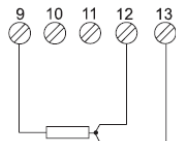

Current ($\pm 20\text{mA}$)

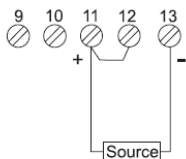

2-wire 20mA Transmitter

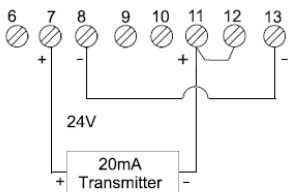

Voltage Measurement

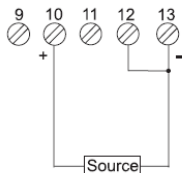

Bridge Measurement

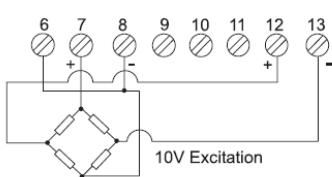

Potentiometer

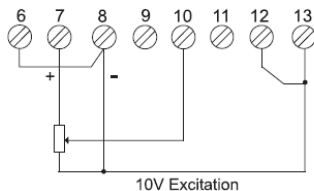

Transducer Supply

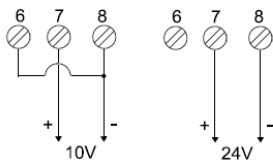

Powering the Instrument

THERE ARE 2 SUPPLY VARIANTS: a mains supply variant and a low voltage supply variant. The instrument is designed to operate from either an AC supply with voltages in the range 90 to 230V AC 50/60Hz mains supply or from a DC supply with voltages in the range 24 to 32V DC (20 to 30V AC) 50/60Hz low voltage supply with a maximum power consumption of 20VA when all outputs are fully loaded and the display has all segments illuminated.

The diagrams below show how the instrument should be connected to the mains supply. Isolation should be provided by a double pole switch and a time delay 200mA fuse.

WARNING - The instrument is designed for installation in an enclosure which provides adequate protection against electric shock. Access to power terminals should be restricted to authorised skilled personnel only. Application of supply voltages higher than those for which the instrument is intended may compromise safety and cause permanent damage.

Recommended Mains Supply Connections

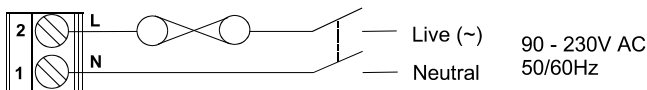

Recommended Low Voltage Supply Connections

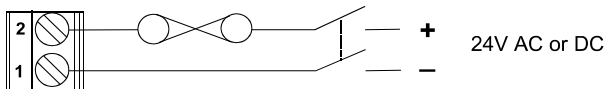

BEFORE POWERING UP THE INSTRUMENT, check the model label on the underside of the instrument for the supply variant, eg. MAINS OR LOW VOLTAGE.

Operator Functions

These functions are only available on units which have the front panel push buttons.

Operator/Configuration Mode - Key Functions

From the normal runtime display:



Enter - Accesses the setup menus.



Next - Scrolls forward through the setup menus.



Up - Function Key 1 (see page 17).



Down - Accesses the alarm setpoint(s). Use the **Next** Key for viewing and the **Enter** Key for editing.



Star - Function Key 2 (see page 17).

NOTE: Units which have the front panel push buttons are externally configurable. Units which do not have front panel push buttons are internally configurable (see page 9).

The Setup Menu

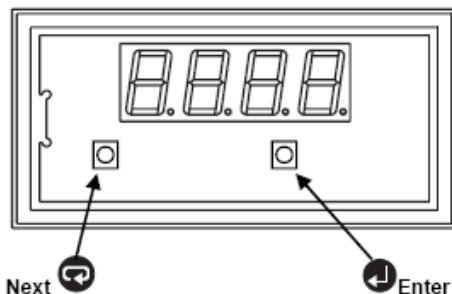

Behind the Front Panel

The instrument uses a single level menu structure. The menu system lists *parameters* (eg. *inPt*, *unit*, *dP*, etc.), each of which leads to a list of configurable instrument *options* (eg. the parameter *inPt* leads to the options *mV*, *mA*, *VoLt* etc.).

To enter the setup menus:

1. Remove the front cover by pushing the extraction tool into the gap below the bezel and then pulling the tool forward to unclip the bezel as shown in the diagram below.

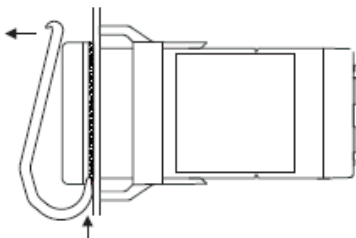

Removing the Bezel with the Extraction Tool

2. Press and hold down the **Enter** Key for approximately 3 seconds until the display begins to flash.
3. Press the **Next** Key and the flashing display should be replaced with the message *inPt* (the first menu parameter).
4. To cycle through the menu parameters, press the **Next** Key repeatedly.
5. To view a menu parameter, press the **Enter** Key and the current option for that parameter will be displayed.
6. To cycle through all of the available options for a parameter, press the **Next** Key.
7. Press the **Enter** Key to select the required option.

8. a) Editing a Setting

Some parameters are setup by selecting from a list of options (eg. the parameter *unit* has 3 options: **°C**, **°F** and **EnG**).

The following example will show you how to edit a parameter. We will change the decimal places (labelled **dP**) from 1 to 2.

- With the unit displaying the measured value, press and hold down the **Enter** Key for approximately 3 seconds until the display begins to flash.
- Press the **Next** Key and the flashing display should be replaced with the message *inPt* (the first menu parameter).
- Press the **Next** Key repeatedly until **dP** is displayed.
- Press the **Enter** Key and *nnn.n* will be displayed.
- Press the **Next** Key and the decimal point will move and *nn.nn* will be displayed.
- Press the **Enter** Key to save this setting and exit. When the **Enter** Key is pressed, the display will return to the menu parameter, ie. **dP**.
- Press the **Next** Key repeatedly to scroll through the rest of

the menu parameters until the measured value display is restored.

b) **Editing a Value**

Other parameters are changed by editing a value (eg. the parameter **HdSP** has a default numeric value of [**100.0**]).

Press the **Next** Key to edit the flashing digit and the **Enter** Key to select the next digit for editing.

The following example will show you how to edit a numeric value. We will change the high display value (labelled **HdSP**).

- With the unit displaying the measured value, press and hold down the **Enter** Key for approximately 3 seconds until the display begins to flash.
- Press the **Next** Key and the flashing display should be replaced with the message *inPt* (the first menu parameter).
- Press the **Next** Key repeatedly until **HdSP** is displayed.
- Press the **Enter** Key and **100.0** will be displayed (with the least significant digit flashing).
- Press the **Next** Key to scroll through digit values **0** to **9** and edit the least significant digit.
- To move to the next most significant digit, press the **Enter** Key and the digit will flash.
- Repeat the previous 2 steps until the left most significant digit is flashing.
- Press the **Next** Key to scroll through digit values **-1**, **-** and **0** to **9**.
- If the value allows the **dP** position to be moved, the **dP** will flash. To move the **dP** position, use the **Next** Key.
- Press the **Enter** Key to save this value and exit. When the **Enter** Key is pressed and the left most significant digit is flashing, the display will return to the menu parameter, ie. **HdSP**.
- Press the **Next** Key repeatedly to scroll through the rest of the menu parameters until the measured value display is restored.

Configuration Menu Map

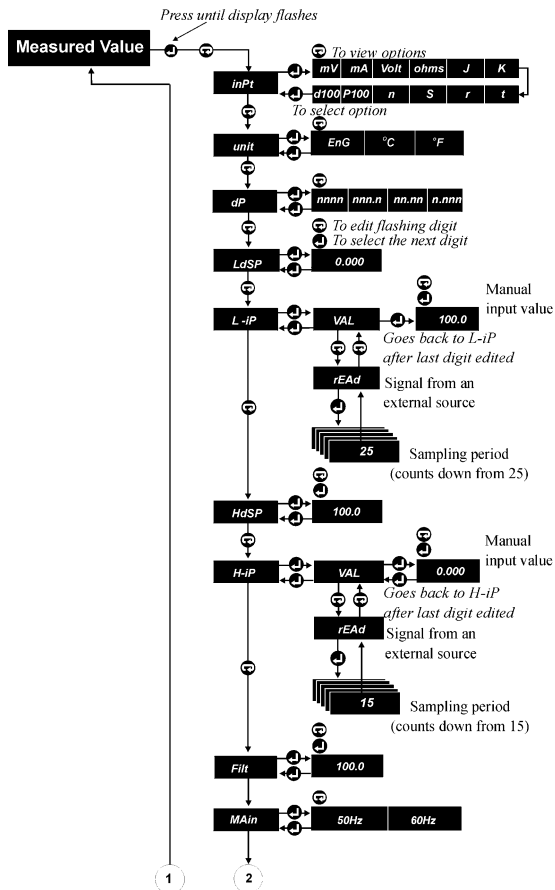

Temperature & Process Measurement Indicators Setup Guide

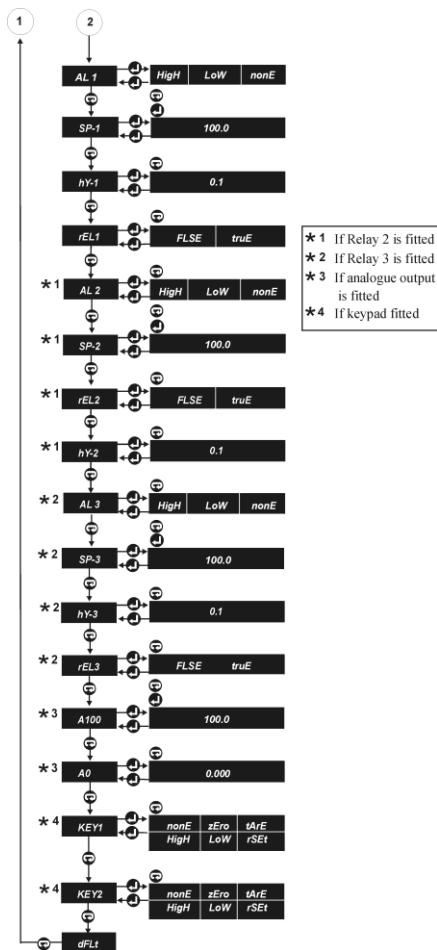

Menu Options

Input

Default: mV

inPt Allows the input type and range to be defined. There are 12 ranges for measurement available. When a thermosensor range is selected, ie. **J**, **K**, **t**, **r**, **S**, **n** or RTD, the instrument will automatically set the appropriate scaling in °C. **Note:** Due to the limitations of a 7-segment display, the **mA** option is displayed as **na**, the **mV** option is displayed as **nu** and the **ohms** option is displayed as **ohns**.

Engineering Units

Default: Eng

unit Allows the user to define the units of measurement to be displayed in °C, °F and **Eng** (linear engineering units).

Decimal Position

Default: 1

dP Defines the position of the decimal point for the display; **0** or **1** for thermocouples/RTD and **0** to **3** for process inputs.

High and Low Display Values *Default: Low = 000.0, high = 100.0*

HdSP **LdSP** The low display value **LdSP** is used for scaling purposes when combined with the other scaling parameters **L-iP**, **HdSP**, and **H-iP**. These 4 parameters can scale the measured input to any engineering units as long as the relationship between the displayed units is linear. **LdSP** is used to define the value to be displayed for an input defined by **L-iP**. **HdSP** is used to define the value to be displayed for an input defined by **H-iP**.

High and Low Input Values

H-iP **L-iP** Correspond to the signal output values from the sensor which will cause the instrument to display the values set as **LdSP** and **HdSP**. **L-iP** and **H-iP** can be input in mV, V, mA etc.

VAL **rEAd** There are 2 methods of setting the low and high input values, either by manually entering a signal value using the **VAL** option or by sampling the sensor output using the **rEAd** option. Values entered manually are entered in the same way as other numeric values (see

Editing a Value page 11). The value to be entered will usually be supplied with the data accompanying your sensor. However, if it is not available, the output from the sensor may be **rEAd** from an external source by the instrument. When performing a **rEAd** input as part of the scaling process, the sensor must have the corresponding physical value applied. This may be pressure, weight, temperature etc. The instrument will sample the output from the sensor and save this as the **L-ip** and **H-ip** scaling parameters.

An example of scaling: 0 - 100 mV = 0 - 1000 (psi)
LdSP = 0 **L-iP** = 0 (mV)
HdSP = 1000 **H-ip** = 100.0 (mV)

Display Filtering

Default: 000

Filt This parameter is used to apply a digital filter to the display value. The filter is defined in seconds which approximate to the time constant. This parameter would be used to damp out any effects from noisy signals.

Mains Frequency

Default: 50Hz

MAin Set to the mains frequency dependent on the local mains supply.

Alarm Messages Display

Default: On

AdSP Enables display alarm messages when set to **on** or disables messages when set to **oFF**.

NOTE: Alarm 3 has the highest priority for messages and Alarm 1 has the lowest.

Alarm 1 Mode

Default: None

AL 1 Defines whether Alarm 1 is disabled when set to **nonE** or operates as a high or low alarm.

AL 2 **AL 3** As Alarm 1 if Alarms 2 and 3 fitted.

Alarm Setpoint 1

Default: 100.0

SP-1 Defines the alarm setpoint for Alarm 1 in display units.

SP-2 **SP-3** As Alarm Setpoint 1 if Alarms 2 and 3 are fitted.

Hysteresis 1

Default: 0.1

hY-1 Specifies the size of a band around an Alarm Setpoint within which the measured value may fluctuate without the alarm state changing. It is in the same engineering units as the displayed value and the Setpoint. The hysteresis value defines both the **on** and **off** hysteresis.

on hysteresis: For a high alarm it is the value (in engineering units) above the setpoint beyond which the alarm is turned on. For a low alarm, it is the measured value below the setpoint beyond which the alarm is turned on.

off hysteresis: For a high alarm it is the value (in engineering units) below the setpoint beyond which the alarm is turned off. For a low alarm, it is the measured value above the setpoint beyond which the alarm is turned off.

The default hysteresis value for all alarms is 0.1.

hY-2 **hY-3** As Hysteresis 1 if Alarms 2 and 3 are fitted.

Relay 1

Default: True

rEL1 Defines the operation of Relay 1, which can be in either the energised alarm state (**trueE**) or the de-energised alarm state (**FLSE**).

rEL2 **rEL3** As Relay 1 if Alarms 2 and 3 are fitted.

A100

Default: 100.0

A100 Defines the display value which corresponds to 20mA or 10V from the optional analogue retransmission.

A0

Default: 0.0

A0 Defines the display value which corresponds to 4mA or 0V from the optional analogue retransmission.

Key 1

KEY1 On units fitted with the front panel buttons, the following functions may be assigned to either or both function keys: zero, tare, display high (maximum) or low (minimum) value since last reset or reset of the high and low values to the current measured value. See **Default** (below) for related information.

Key 2

KEY2 As for Key 1.

Default

Default: Off

dFLt Allows the instrument to be returned to its factory supplied setup.

NOTE: On a 211 with front panel keys, defaulting the unit removes the Key1 and Key2 options from the setup menu. Immediately after defaulting the unit, press either one of the function keys (up-arrow or star) to restore these options.

Messages

brk The input circuit, when measuring mV, thermocouple or RTD, has detected an open circuit sensor connection. When a sensor break is detected by the instrument, the measured value will be forced upscale causing any high alarms to be activated.

undr **oVER** Displayed when the measured value goes out of its allowed range, either outside the normal range of the connected thermosensor or the maximum/minimum display range for the decimal places set.

Alarm Messages

Alarm messages are 3 letters followed by the alarm number. The codes are:

HiA1 **HiA2** **HiA3** High alarm. Eg. **HiA3** indicates high Alarm 3 has been activated.

LoA1 **LoA2** **LoA3** Low alarm.

NOTE: Alarm 3 has the highest priority for messages and Alarm 1 has the lowest.

DSPM *Industria*[®]
sensori & trasduttori

Via Paolo Uccello 4 - 20148 Milano
Tel +39 02 48 009 757 Fax +39 02 48 002 070
info@dspmindustria.it www.dspmindustria.it